

# Surface Science Activities

---

Each of the two astronauts that descend to the lunar surface in the LM will spend about 21 hours in three periods of 7 hours outside the LM working on the lunar surface. Most of that time will be used to study geological features, collect and document samples of rocks and soil, and set up several experiments that will be left behind on the lunar surface when the astronauts return to Earth.

The surface traverses described in this guidebook, which was written about 3 months before launch, should be considered as general guides for the astronauts to follow. From previous Apollo missions, we have learned that although some minor changes in plans are likely to occur, major changes are unlikely. On each mission a few changes were made by the crew because of unforeseen conditions. Instructions to the astronauts have always been "to use their heads" in following the detailed plans and the Apollo 17 mission is no exception. In addition, the astronauts may consult over the radio with a group of scientists located in Mission Control at Houston and decide during the mission to make some changes. Undoubtedly some details of the traverses will change. Equipment changes, on the other hand, are very unlikely to occur because all of the equipment had been built and was being stowed in the spacecraft at the time of writing.

## TRAVERSE DESCRIPTIONS

The planned Rover traverses are shown in figure 20. The activities at each of the stops on all three traverses and along each traverse between stops are shown in Table 2. In order to use Table 2 effectively, the reader must have scanned most of the next section, "Surface Scientific Experiments and Hardware", and to have read the section "Lunar Geology Experiment."

The numbers assigned to each of the traverse

stations shown in the figures and tables of this guidebook are current at press time (1 October 1972) and are not expected to change. However, extra stations may be added or deleted, before, as well as during, the mission. These extra stations will be given a special designation to avoid confusing them with the existing stations.

During the 75-hour lunar stay, three 7-hour EVA's are planned. On EVA 1, most of the time will be spent readying the Rover, setting up ALSEP and other experiments, but about two hours will be used for a traverse to Station 1. The primary geology objectives of EVA 1 are to investigate the SUBFLOOR materials and the DARK MANTLE. The chief objectives of EVA 2 are to study and sample the base of the South MASSIF and the LIGHT MANTLE material found in the debris slide. Then on EVA 3, the astronauts will investigate and sample the North MASSIF and SCULPTURED HILLS material that lies to the north and northeast of the landing site. They will further investigate and sample the DARK MANTLE material and the SUBFLOOR material. During all three traverses, the crew will not only study geology but will also collect geophysical data. The LSP charges will be placed on the Moon. Gravity will be measured at several places with the Traverse Gravimeter. And SEP data will be obtained continuously and automatically along the traverse routes.

In the event that the Rover becomes inoperative sometime during the mission, a series of walking traverses has been planned. Because the maximum distance that an astronaut can walk safely on the Moon is set by the amount of oxygen and other supplies that he carries, the walking traverses extend only 3 to 3½ km from the LM. The general objectives of walking EVA's are the same as those for the Rover traverses. The astronauts will study and sample the North MASSIF, the SUBFLOOR, and the DARK MANTLE material

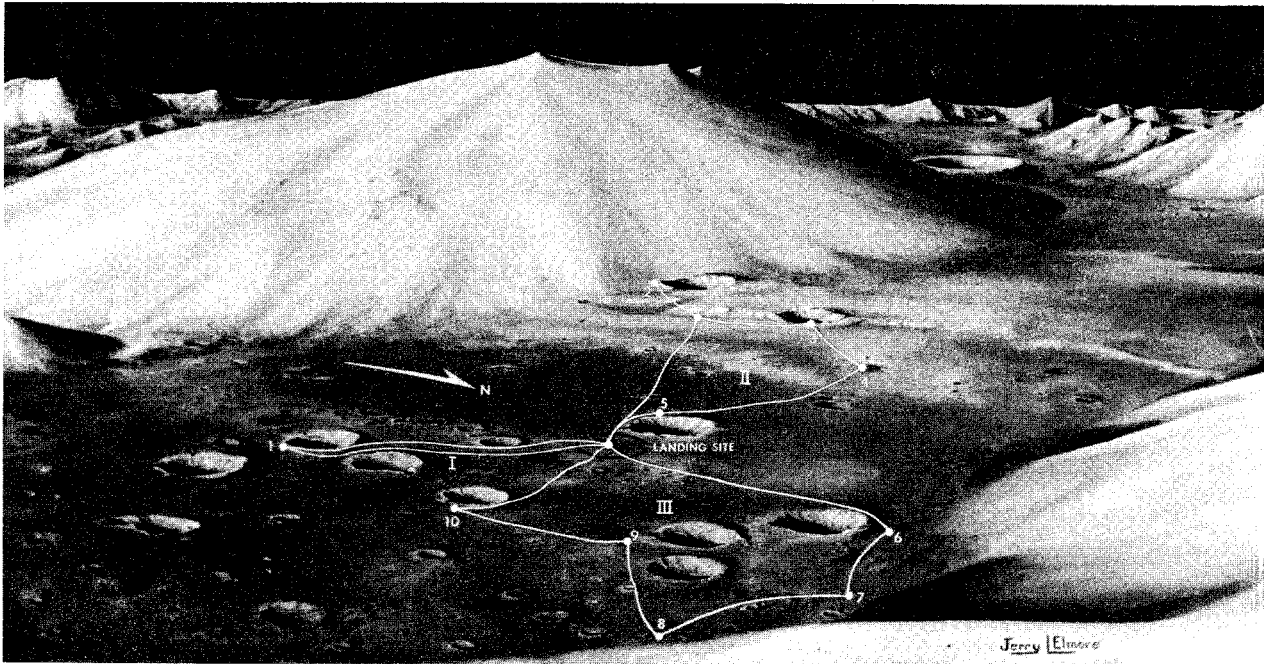

FIGURE 20A.—The traverses planned for use with the Lunar Roving Vehicle. The roman numerals indicate the three EVA's. The numbers are station stops. The station stops are keyed to the information given in Table 2. These same traverses are shown in figure 20B, an overhead view of the landing site. Drawn by Jerry Elmore. NASA PHOTO S-72-49760.

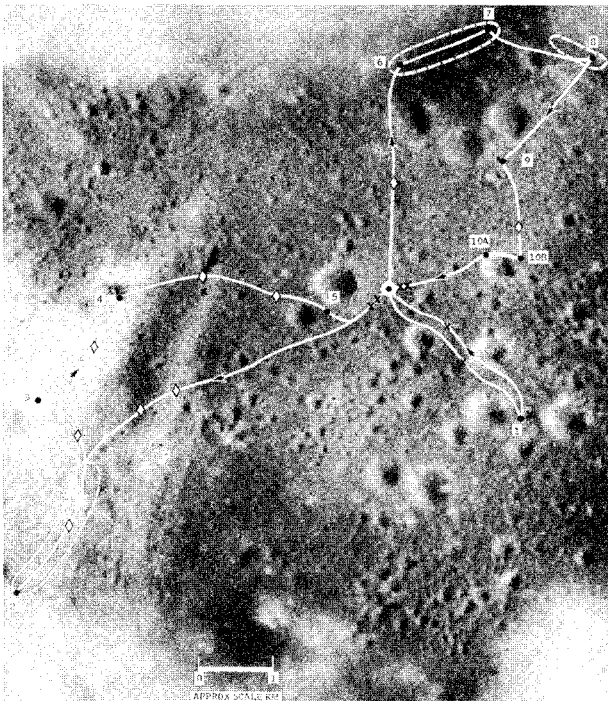

FIGURE 20B.—The traverse routes shown on the photograph of the site. This photo obtained on Apollo 15, has been used extensively in planning the surface activities. Locations of LRV-samples are shown with diamonds, of LSPE charges are shown with X's. Enlargements of each EVA traverse area are shown in other figures. North is at top of photo. NASA PHOTO S-72-50305.

at as many Rover traverse stations as possible. But because of the major limitation of distance, only Stations 1, 5, 6, 9, and 10 could be visited on walking traverses.

In planning for contingencies, we have placed many data into computers so that we can recall them immediately when we need them. For example, we are able to generate in the computer the view that will be seen by the astronauts from any position at the landing site and along the landing trajectory itself. In figure 21, I show the computer output for several successive views along the Taurus-Littrow landing trajectory, as well as a part of the panorama that can be seen from the LM touchdown point.

## LUNAR SURFACE SCIENTIFIC EXPERIMENTS AND HARDWARE

Several different kinds of experiments will be done at Taurus-Littrow. The astronauts will collect samples of lunar material to be returned to Earth and will describe the geological features of the site. They report these descriptions over radio. (The transcript of each EVA on previous missions fills many pages!) They will set up several scien-

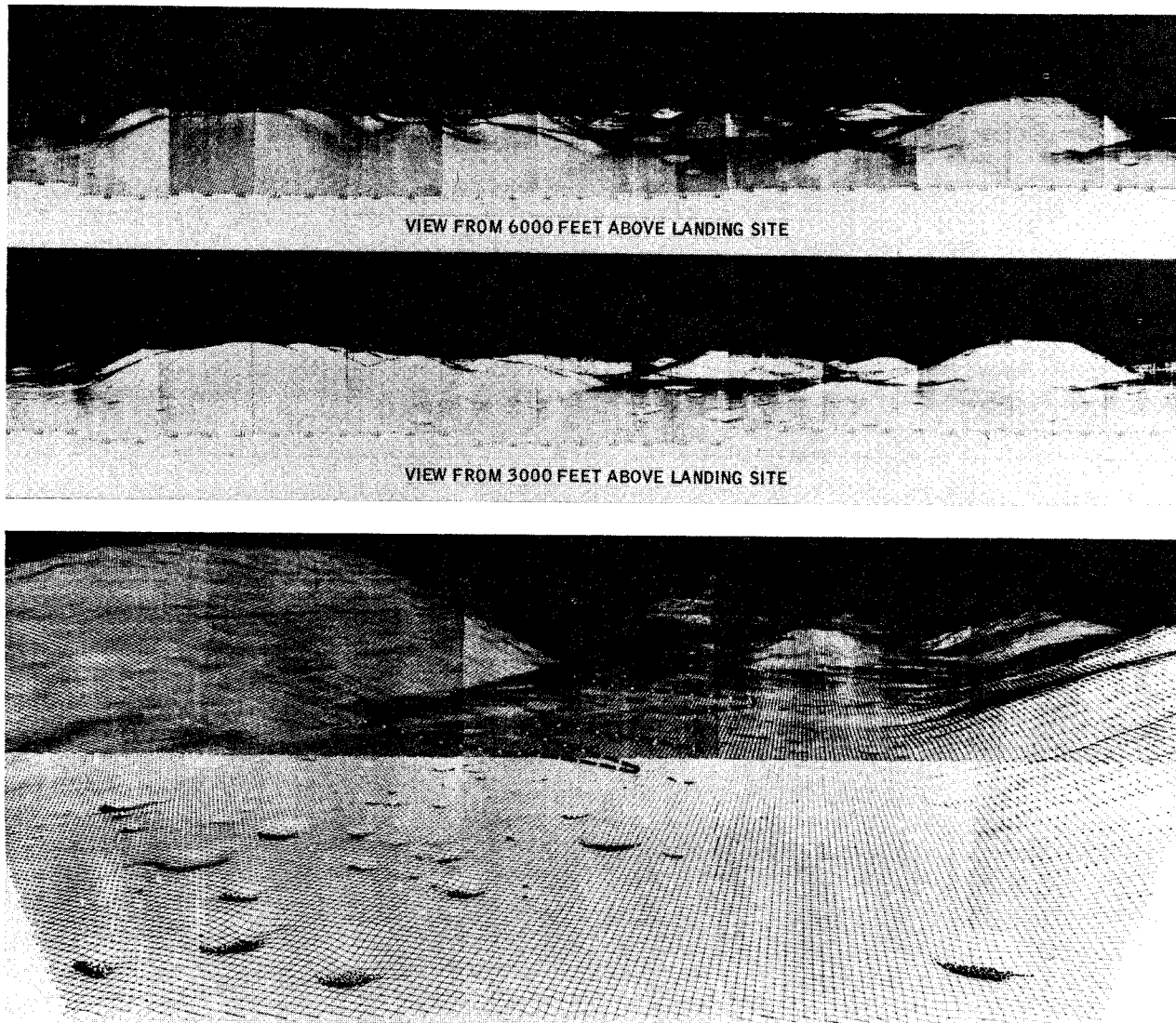

FIGURE 21.—Various views of the Taurus-Littrow site generated in a computer and plotted automatically. A and B are views from the LM along the trajectory. NASA PHOTO.

tific experiments on the lunar surface. The equipment for these experiments will remain behind on the Moon after the astronauts return to Earth. Data from these experiments will be sent to Earth over microwave radio links, similar to the ones used extensively for communications on Earth. And finally, three experiments, known as traverse experiments, will be done *along* the routes of the traverses. The equipment for two traverse experiments will be attached to the Rover. I think you can see that the Apollo 17 astronauts will be extremely busy! I wish now to discuss each of the experiments in approximately the sequence that they will be deployed on the Moon.

### Apollo Lunar Surface Experiments Package (ALSEP)

Several of the lunar surface experiments are a part of the Apollo Lunar Surface Experiments Package (ALSEP). General layout of the equipment on the lunar surface is shown in figure 22. A photograph of the Apollo 16 ALSEP, which is similar but not identical to the Apollo 17 ALSEP, is shown in figure 23. The ALSEP central station, figure 24, although not an experiment, provides radio communications with the Earth and a means for control of the various experiments. After the ALSEP is set up, it is quickly checked out from

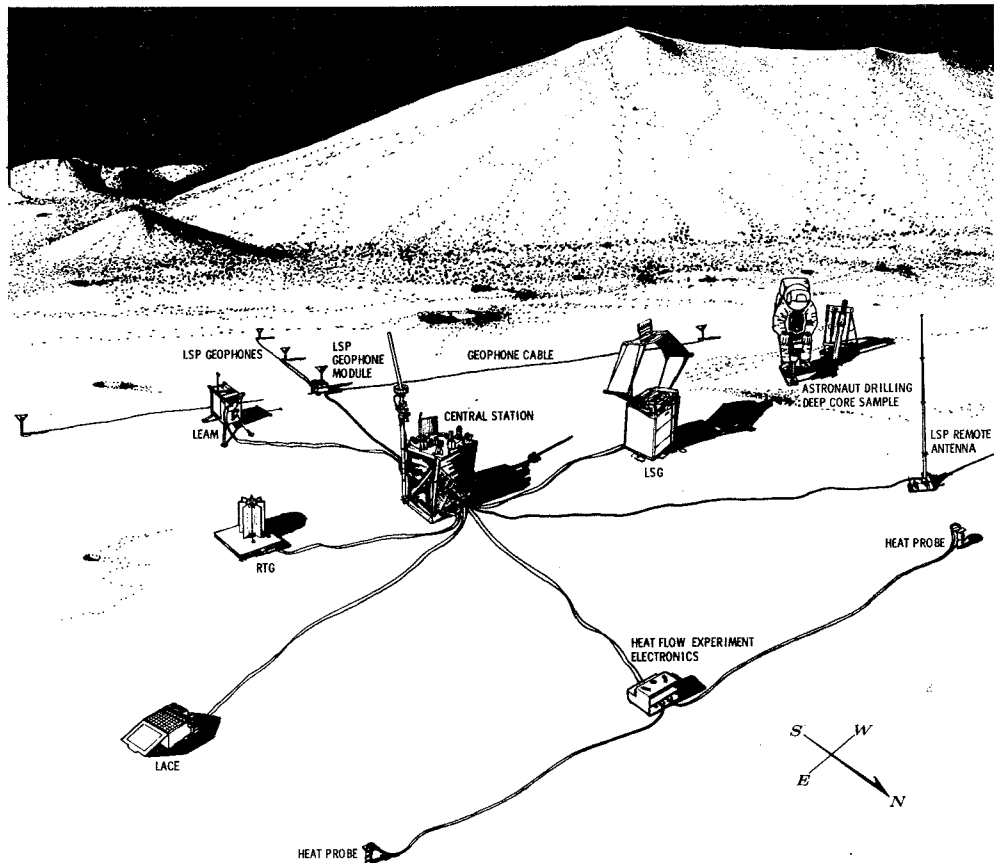

FIGURE 22.—General layout of the ALSEP. Although the astronaut, equipment, and lunar features are drawn to different scales, their locations are shown in true relation to each other. Shown here are the relative positions of the five experiments that are a part of the Apollo 17 ALSEP. (Right) The correct distances (in meters) are shown on a map view of the site. Note that North is towards the bottom of the page. NASA PHOTOS S-72-49618 and S-72-49617.

Earth and then after the astronauts leave the Moon, commands continue to be sent from Earth for control of the various experiments during the lifetime of the ALSEP. The experiments connected electrically to the central station are the Heat Flow Experiment, the Lunar Surface Gravimeter, the Lunar Atmospheric Composition Experiment, the Lunar Ejecta and Meteorite Experiment, and the Lunar Seismic Profiling Experiment.

Electrical power for the experiments on the lunar surface is provided by the decay of radioactive plutonium in a device termed a Radioisotope Thermoelectric Generator (RTG), shown in figure 25. A total of roughly 70 watts is delivered. Let me draw special attention to this power of 70

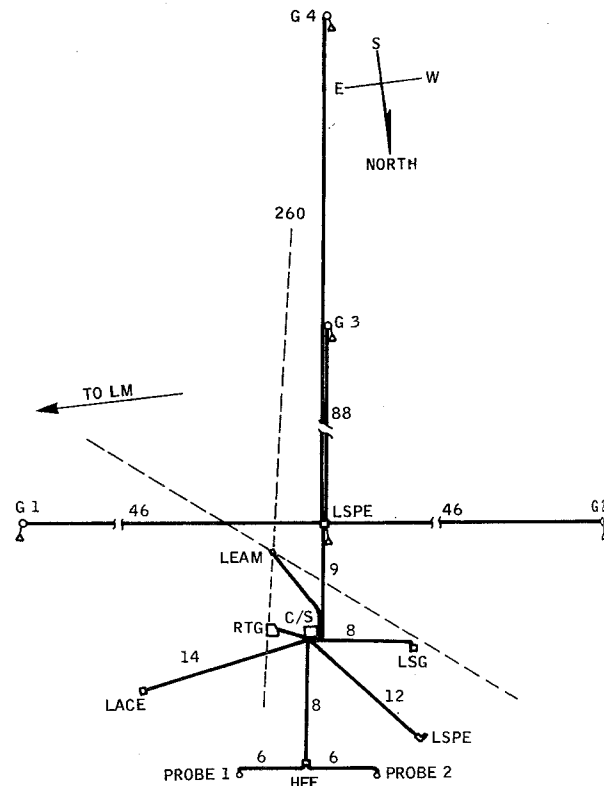



FIGURE 23.—Apollo 16 ALSEP. Note the changes in experiments between 16 and 17. NASA PHOTO AS16-113-18373.

watts. It is truly incredible that all of the experiments together, and including the radio that sends the scientific information over a quarter million miles of space to us, use no more power than is consumed by an ordinary 75 watt light bulb! The electrical wires are flat, ribbonlike cables that may be seen in figure 23. The RTG is filled with nuclear fuel after the astronauts reach the lunar surface. The fuel is carried to the Moon in a cask mounted on the side of the LM. The cask is sketched in figure 26 and its location on the LM can be seen in figure 3. The sequence of operations, to be done early in EVA 1, to fuel the RTG is shown in figure 27. The principle of operation of the RTG is very simple. The decay of the plutonium releases energy which causes the capsule to become hot, reaching about 1,300° F within a few hours after fueling. A thermopile\* converts the heat energy to electrical energy.

\* Similar to the thermopiles used in the control circuits of home heating systems. Most home clothes dryers, water heaters, and heating systems that use gas for fuel and have a pilot light contain thermopiles. The thermopile is the small object that projects into the pilot light. Without doubt, you recall lighting the pilot on your water heater and waiting for a short time (usually 1 minute) for the thermopile to become sufficiently hot—and hence generating power—that the pilot would remain lighted.

During EVA 1, the astronauts remove the ALSEP experiment from the LM, carry it to a site some distance from the LM, and place it on the lunar surface. In figure 28, we see astronaut Al Bean carrying the Apollo 12 ALSEP. The 17-ALSEP is carried in a similar way. In figure 29, a sketch of the ALSEP pallet, you can see the packing of the individual items of the ALSEP. A sum-

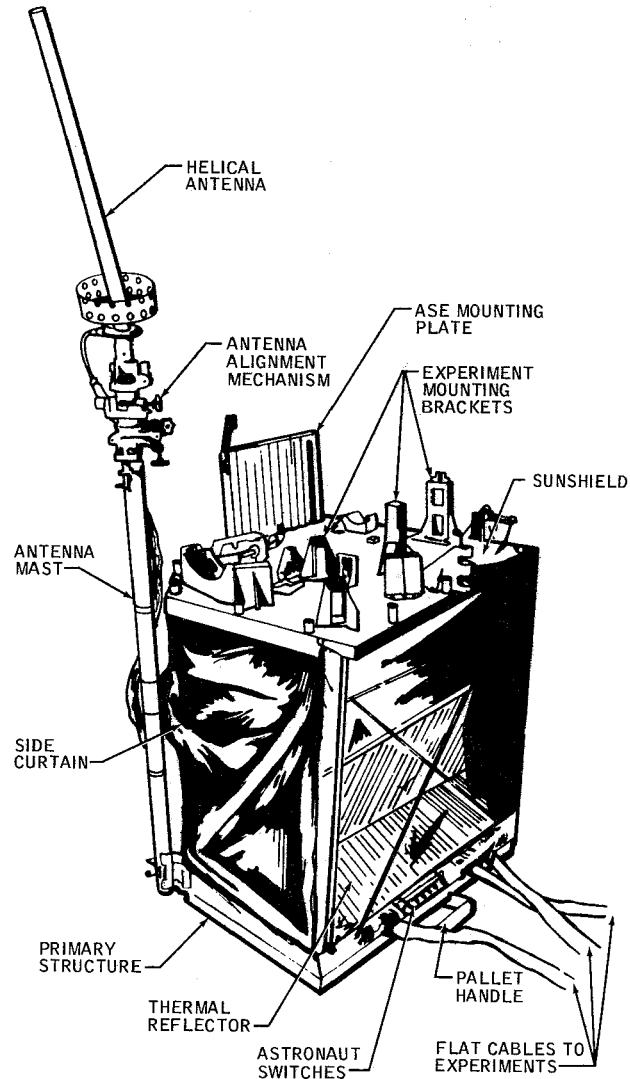

FIGURE 24.—The ALSEP central station. This equipment is connected electrically to each of the other ALSEP experiments. It is a maze of electronics that accepts the electrical signals from various experiments and converts them into a form suitable for transmission by radio back to Earth. The pole-like feature on top of the central station is a high-gain antenna. It is pointed towards the Earth. Commands may be sent from the Earth to the central station to accomplish various electronic tasks. NASA PHOTO S-72-49036.

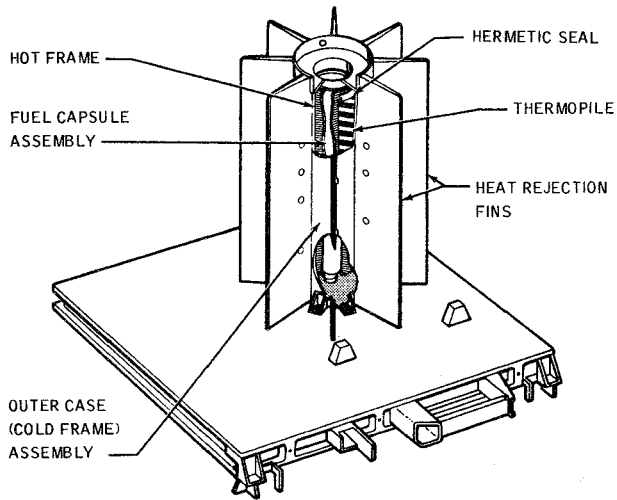

FIGURE 25.—Radioisotope Thermal Generator. This equipment provides all of the power used by the ALSEP. It furnishes continuously about 70 watts. NASA PHOTO 8-71-29730.

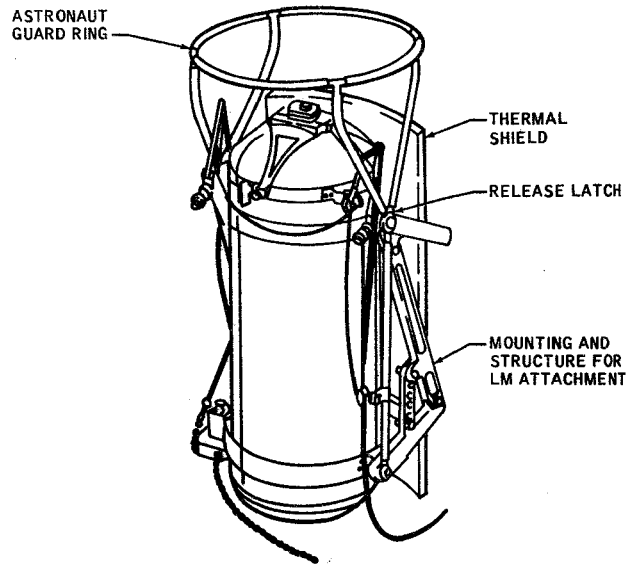

FIGURE 26.—Fuel cask. The fuel, radioactive plutonium, for the RTG is carried to the Moon in this cask, which is mounted outside the LM.

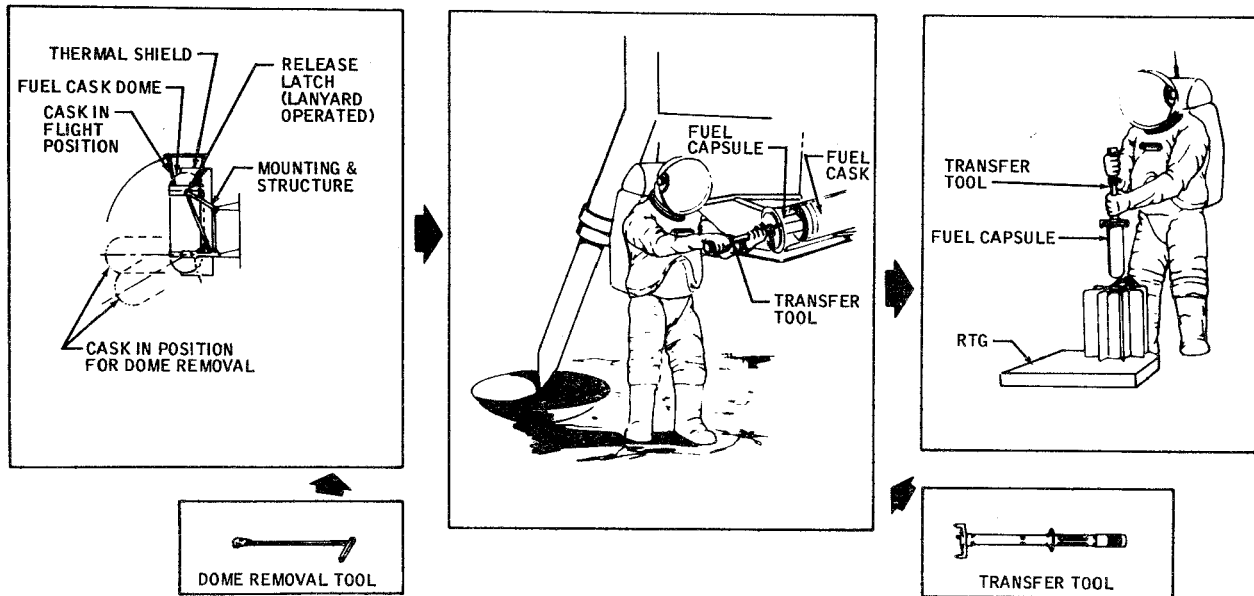

FIGURE 27.—Fueling of RTG. The sequence of operations to be done by one of the astronauts on the Moon to place the capsule of radioactive fuel in the RTG is shown here. The fuel capsule is very hot and so it is handled very carefully. NASA PHOTO 8-72-50295.

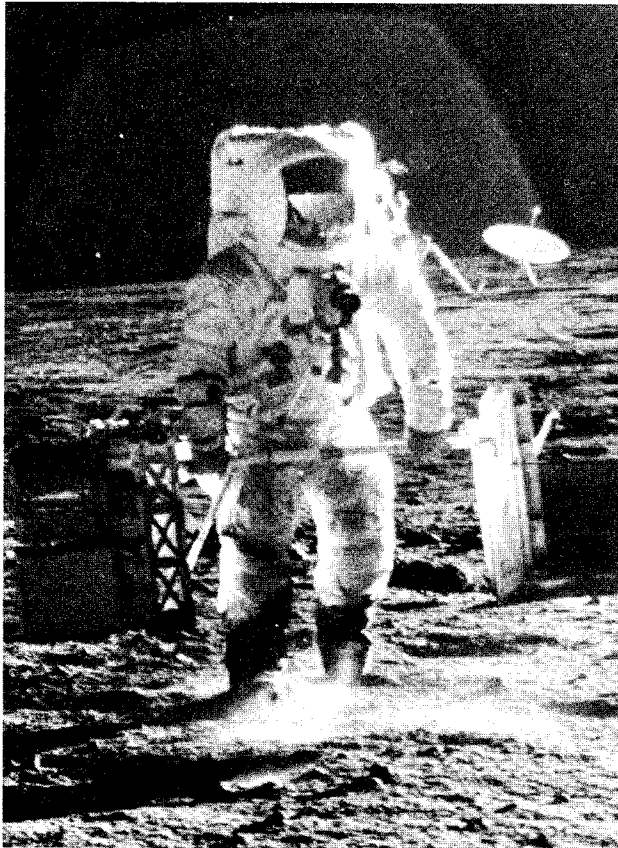

FIGURE 28.—Astronaut Al Bean carrying the ALSEP to its Apollo 12 location. There was no Rover on that mission and the ALSEP location was roughly 100 yards from the LM. The edge of the LM and an S-band antenna are shown in the background. The halo is caused by reflections in the camera lens systems; the halo was not present on the Moon. On Apollo 17 the same technique will be used to carry the ALSEP. NASA PHOTO AS12-46-6807.

mary of the ALSEP operations is given in Table 3. The layout plan for the various ALSEP experiments on the Moon is shown in figure 22.

A list of *all* science experiments of the entire Apollo Program, including those of this mission, is given in Table 4. A list of the Principal Investigators and their institutions is included in Table 5. Finally, you will find in Table 6 a list of the companies that have contributed significantly towards the design, building, and testing of the scientific equipment of the entire Apollo Program.

### Heat Flow Experiment (HFE)

Heat flows from hot regions to cold regions. There is no known exception to this most general law of nature. We are certain that the interior of

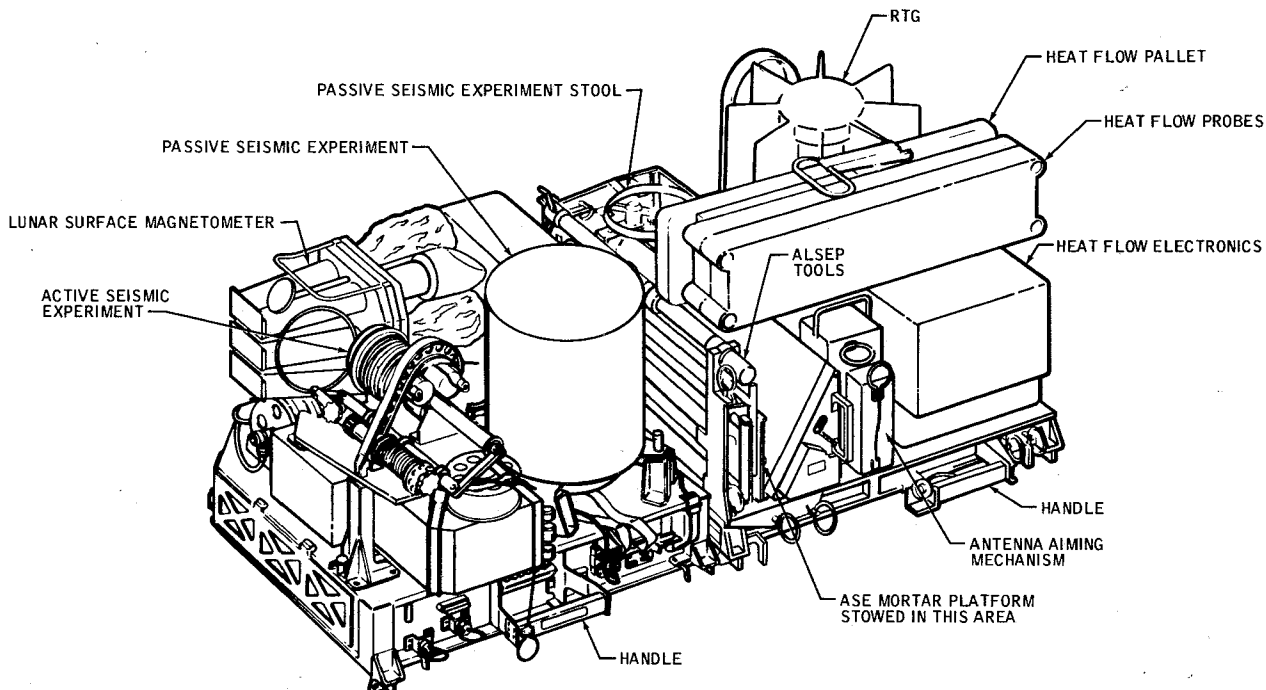

FIGURE 29.—ALSEP pallet. The ALSEP is carried to the Moon in the LM on this pallet. Note how tightly the individual items are packed in order to save space. NASA PHOTO S-72-16330.

the Moon is warm. It may be hot, possibly as hot as 1,200° C. Therefore heat flows from the interior of the Moon to the surface where it is then lost into cold space by radiation. The Heat Flow Experiment (HFE) will measure the amount of heat flowing to the surface at the Taurus-Littrow site.

A similar measurement was made at the Apollo 15 site, the magnificent Hadley-Apennine region. Some of the details were seen over television by millions of viewers. You may recall the problem of drilling the hole into which the astronauts inserted the temperature sensors. That problem was caused by the failure of the drill to expel the cuttings from the hole. The drill was redesigned and worked satisfactorily on Apollo 16. However the HFE was destroyed on Apollo 16 when an astronaut tripped over the cable connecting the HFE to the Central Station.

But let me continue with the main story of heat flow. At the Apollo 15 site, we measured a value about  $\frac{3}{4}$  unit.\* Let me explain this unit in the following way. If we were able to store the heat that flows to the surface of the Moon through a square foot from the interior during an *entire year*, it would just be enough to melt a layer of ice  $\frac{1}{10}$  inch thick. Not very much heat, is it? Perhaps. Yet on Earth, the average heat flow is only about twice that value and it has produced our mountains, it causes the earthquakes so familiar in California and other regions of the United States as well as many parts of the Earth, it produces the volcanoes, and so on. I have always been awed by how much nature can do with so little per year! Of course I must add, for so long a time, and that is the key.

But by comparison with the Earth, the Moon is seismically rather quiet. Earthquakes on the Earth exceed one million per year. On the Moon, there may be 300 to 400. And they are much smaller than the ones on Earth. We are not yet sure why.

At the present time, the heat flowing to the surface of the Moon from the interior has been produced mostly by slow decay of the natural radio-active elements thorium, uranium, and potassium. Measurements made directly on the lunar samples returned to Earth by previous Apollo missions have revealed the presence of significant amounts of these elements. The normal spontaneous change of these elements into other elements

\* The "unit" here is micro calories/square centimeter/second.

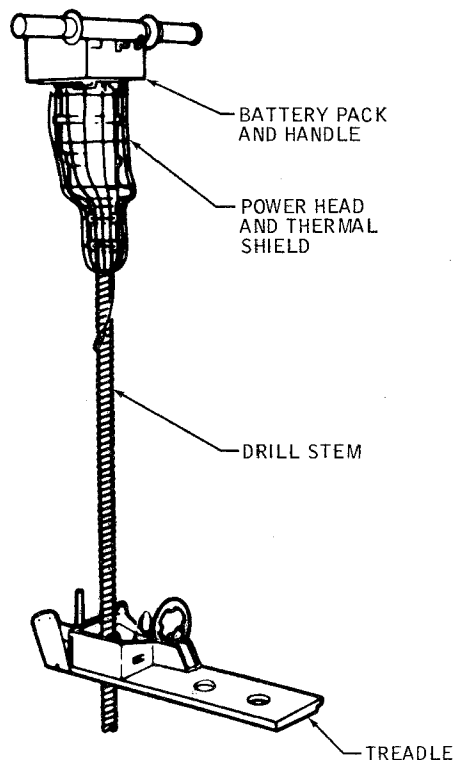

FIGURE 30.—Lunar surface drill. This drill will be used to drill holes on the Moon to a depth of about 10 feet. It is electrically powered and operates from batteries. The treadle is used to steady the drill stem and to deflect cuttings from striking the astronaut. Two holes are used for the heat flow experiment and a third one is used to obtain samples for study back on Earth. A rack, used for holding the drill stem, is sketched in figure 22.

slowly releases energy. The process is similar to that used in nuclear reactors on Earth to generate electrical power from uranium. In the Moon, most of the energy appears in the form of heat which raises the temperature of the interior of the Moon.

In addition to the amount of radioactive material present, the internal temperature of the Moon depends on other things. The properties of lunar rocks and soil are equally important. The thermal conductivity of a material is a measure of the relative ease with which thermal energy flows through it. Rather well-known is the fact that metals are good conductors and that fiberglass, asbestos, and bricks are poor conductors. Most of us would never build a refrigerator with copper as the insulation. Values of the thermal properties of rocks are closer to those of fiberglass than those of copper and other metals. Rocks are fairly good insulators. The lunar soil is a very good insulator.



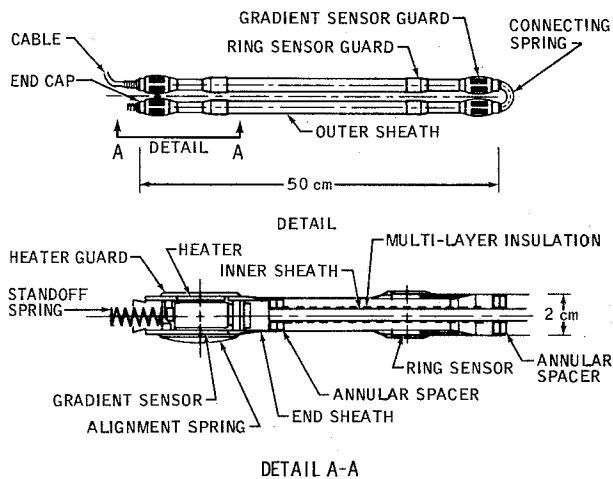

FIGURE 31.—Details of the Heat Flow Probe. The probe is shown here in the way that it is carried to the Moon, folded to save space. The connecting spring allows the probe to be straightened before placing it in the hole. In addition to the platinum sensors contained in the probe and shown in this figure, the cable contains several thermocouples.

The HFE has been designed to measure the rate of heat loss from the interior of the Moon. To obtain this measurement at the 17-site, two holes are to be drilled into the surface of the Moon by one of the astronauts to a depth of about 8 feet by means of the drill sketched in figure 30. After each hole is drilled, the probes sketched in figure 31 are placed in the holes. The probes contain very precise temperature sensors (platinum resistance thermometers) for the lower parts of the holes. The connecting cables contain several thermocouples (which also measure temperatures but with lower precision) which will be located in the upper portions of the holes. See figure 32. The thermal properties of the rocks will be measured by the equipment that is placed in the hole; they will also be measured on samples that are returned to the Earth.

Because the temperature of the rock is disturbed by the drilling process, the various measurements for heat flow will be taken at regular intervals over several months. As the residual heat left around the hole from the drilling dissipates with time, the temperatures measured in the experiment will approach the undisturbed temperatures of the Moon.

The HFE is important because knowledge of the rate of heat flow lets us set limits on the internal temperature and on the amount of radioactive

elements now present in the Moon. You see, the amount of such radioactive material already measured in the lunar samples on Earth is embarrassingly high! We know that such samples cannot be representative of the whole Moon, because if they were, then the Moon's interior would be molten throughout. Yet we are sure that it is mostly solid throughout. By establishing limits on the radioactivity, we will come closer to a correct understanding of the thermal history of the Moon.

Incidentally, the value of heat flow measured at the 15-site was completely unexpected. It was at least twice the value that most scientists had anticipated. So I think you can understand why we are particularly anxious to see if the Apollo 17 measurements confirm this surprising result.

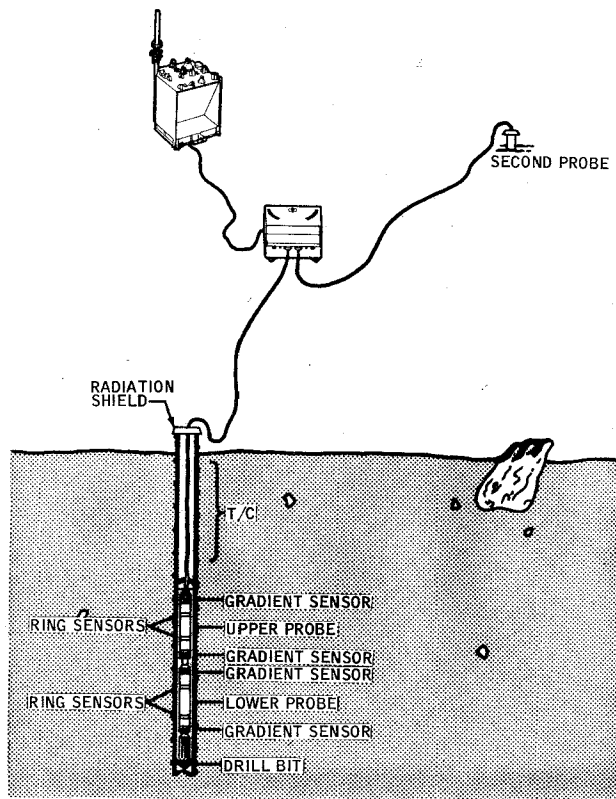

FIGURE 32.—Heat Flow Experiment. Probes are placed in two holes drilled in the lunar surface with the drill shown in figure 30. One hole is shown in the figure as a section to show the various parts. The gradient is the difference of temperature at two points divided by the distance between the points. Heat flow is determined by measuring both the gradient and the thermal conductivity; heat flow is the product of gradient and thermal conductivity. The symbol T/C indicates thermocouples that are present in the upper part of the holes.

## Lunar Surface Gravimeter (LSG)

When electrons are accelerated, they radiate electromagnetic energy. Exactly that process is used to "broadcast" radio programs and television programs. When masses are accelerated, they *should* radiate gravitational waves, as predicted by the general theory of relativity. Efforts to confirm the existence of gravitational waves have been successful only recently. Dr. Joseph Weber has detected gravitational waves that pass through the Earth and come from the direction of the center of our galaxy. See the May 1971 issue of *Scientific American* for a very readable and exciting account of the work of Weber and associates in their efforts to detect gravitational waves on the Earth. In fairness, I must say that many knowledgeable scientists would disagree today with the view that gravitational waves have now been detected!

The primary purpose of the Lunar Surface Gravimeter (LSG) is to search for the presence of propagating gravitational waves in space. Such waves should interact with *both* the Moon and the Earth in certain diagnostic ways. In effect, the LSG experiment will use both the Moon and the Earth as gravitational antennas.

The interaction of the Moon with propagating gravitational waves sets up very characteristic patterns of vibration of the entire Moon—resembling in some ways the ringing of a bell. Similar vibra-

tions would be set up in the Earth. The unequivocal demonstration of the presence of such gravitational waves will be the detection of these characteristic modes of vibration of *both* the Moon and the Earth simultaneously. Thus equipment will be operated on both the Earth and the Moon to test for this condition. The Earth has a high background noise level due to the pounding of the oceans on the coasts, the variations of atmospheric pressure, and the constant rumblings of earthquake activity. Excitation of certain overtones of the Moon should be observable because of the lower noise level. Such observations would be evidence of the interaction of the Moon with gravitational waves.

The equipment that is used for the measurement of such vibrations is an extremely sensitive gravity meter. The heart of such equipment is a very fancy, very tiny, and very delicate version of the old style spring balance, the one on which a pan was suspended on a spring scale.

This mechanism is shown in figure 33. It was developed many years ago for use on the Earth by LaCoste and Romberg. Most of the individual parts, including the main spring, are handmade of iron and aluminum alloys. This mechanism has been used for many years to measure gravity in laboratories (with extremely high precision) and in the exploration of the Earth for oil and gas. So, its characteristics are extremely well known. But the adaptation of this well known and extensively used mechanism to the lunar environment has not been easy because of the very stringent requirements of long life (at least 2 years), of no opportunity for maintenance or repair, of the extreme precision necessary, and of the need to operate remotely and reliably on the Moon. For example, the temperature of the equipment cannot vary more than one thousandth of a degree during any half hour. The equipment will measure variations in lunar gravity as small as one part in  $10^{11}$  (i.e., 100 billion).

The external appearance of the LSG equipment is shown in figure 34.

The LSG will gather data that not only can be used to look for propagating gravitational waves but can be used also for several other extremely important measurements. For example, the deformation of the Moon due to tidal forces caused by the changing positions of the Earth and the Sun will be measured. On the Earth, we are all familiar with the ocean tides. But did you know that the solid rock at every place on the Earth de-

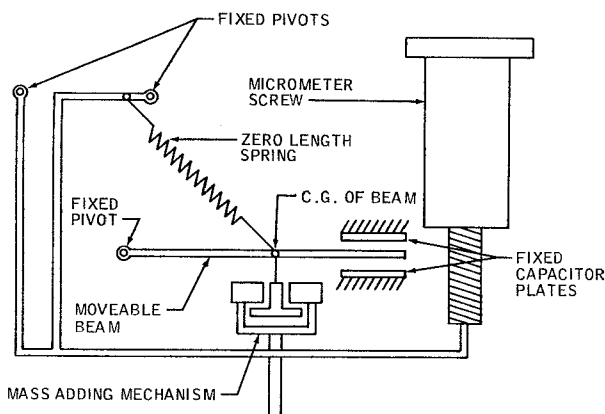

**FIGURE 33.**—Elements of the Lunar Surface Gravimeter. A mass is suspended on a very special spring. Most of the assembly is made of fused quartz glass. The length of the spring is not really zero but the effect of this particular geometry makes the spring appear to have zero length. Motion of the beam (and hence of the mass) is detected and measured electrically with the capacitor plates.

forms in a similar way? It does! Only the heights differ. Oceanic tides are several meters high, those of the solid Earth are usually less than a half meter. Knowledge of the exact deformation of the Moon's surface due to the tidal forces will allow us to determine the internal structure of the Moon.

And finally, the LSG will serve as a single axis seismometer. Thus some seismic information from the Apollo 17 site will be available for comparison with the seismic data from the Apollo 12, 14, 15, and 16 sites.

There is probably no better example in today's world of science of an experiment that is being done primarily for scientific purposes but which holds such great promise for uncountable practical benefits to mankind in the years ahead. The practical utilization of *gravitational* waves may lead to benefits that far exceed those gained from the practical utilization of *electromagnetic* waves. Many of the feats described by yesterday's science fiction writers will be commonplace tomorrow.

### Lunar Atmospheric Composition Experiment (LACE)

In this experiment we measure with a mass spectrometer, the composition and density of gas molecules in the thin lunar atmosphere. Early instruments and the basic technique were developed shortly after the turn of the century. The principle can be understood by referring to figure 35. Gases enter the instrument through a gas inlet manifold and pass through an electron beam. The electrons in the electron beam knock loose one or more electrons from the gas molecules to produce ions. An ion is merely a gas molecule which has lost one or more electrons. It has both mass and charge. The ion proceeds on through the instrument and is focused into a narrow beam. It then passes through a *magnetic* field. Now the flow of charged particles constitutes electric current flow, and current flowing in a magnetic field will have a force exerted on it. This statement is the basic principle of all electrical motors. It was discovered many years ago. Each time that you start your automobile engine, you close a switch which causes current to flow in a conductor through a magnetic field with the result that a force is exerted on the conductor and (hopefully, at least for my car) the engine starts.

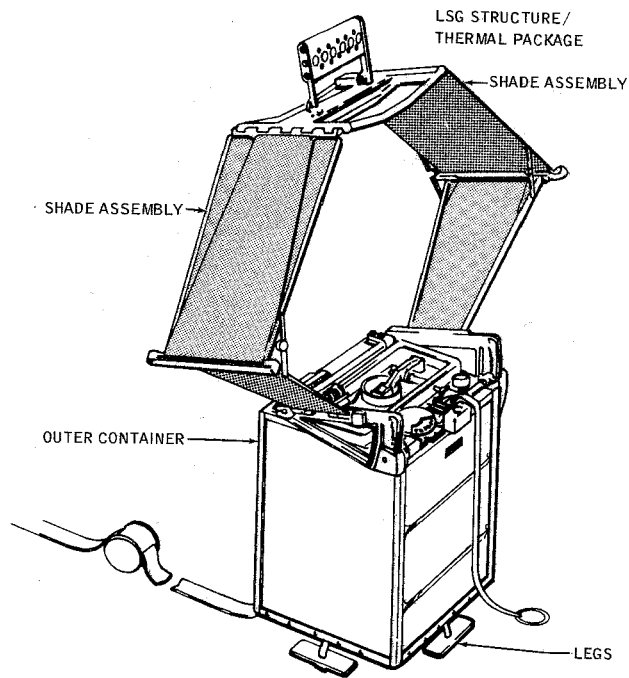

FIGURE 34.—Lunar Surface Gravimeter. The large structure on top of the LSG box shades the box from the Sun's direct rays to help with the extreme temperature control required of this equipment. NASA PHOTO S-72-49039.

In the spectrometer, the force that is exerted on each ion depends upon the strength of the magnetic field, upon the velocity with which the ion is moving, and upon the number of electrons that were lost. In the magnetic field, the ion follows

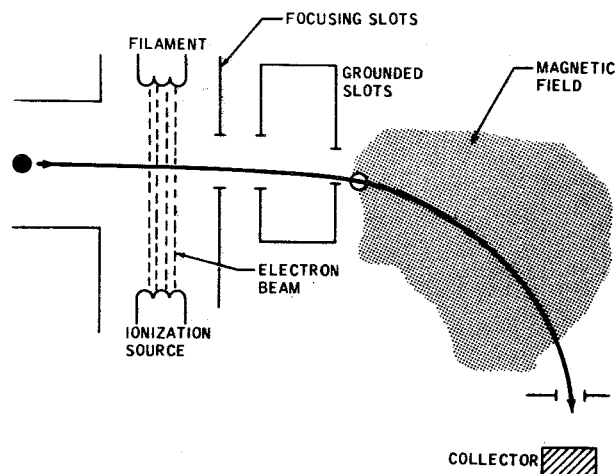

FIGURE 35.—Principle of the mass spectrometer. The magnetic field is perpendicular to the plane of the paper. See discussion in text. NASA PHOTO S-72-50319.

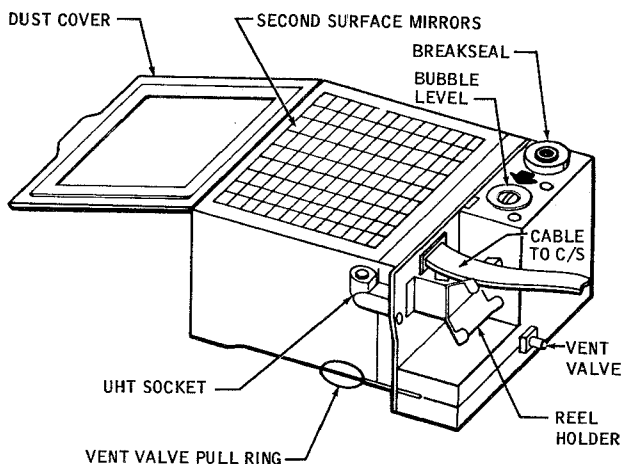

FIGURE 36.—Lunar Mass Spectrometer. This box contains a magnet, ion source, and associated electronic components. Data are transmitted to Earth through the ALSEP central station.

a circular path. The radius depends, in addition to the factors just mentioned, upon the mass of the ion. By changing the velocity with which the ions travel and measuring the number of ions that pass through the small opening into the collector, we can, in effect, determine the masses of the ions that are present. Essentially this same procedure is used in the Apollo 17 mass spectrometer.

The external appearance of the LACE equipment is shown in figure 36. The box contains all of the components shown in figure 35 plus some rather sophisticated electronics. The mirrors are used for cooling the package. The astronauts set the LACE on the Moon's surface, level it and connect the electrical cable to the ALSEP central station. The dust cover is opened on command from Mission Control after the astronauts have left the Moon. (Dust has an extremely bad effect on the radiating properties of surfaces. There is a long history of minor difficulties associated with dust on radiating surfaces of equipment deployed on the lunar surface in the Apollo Program.) The data are sent to Earth over the ALSEP telemetry link.

Several sources of gas for the lunar atmosphere are known to exist. Volcanoes, even though dormant and not erupting liquid rock, vent such gases as carbon monoxide, hydrogen sulfide, ammonia, sulphur dioxide, argon, and water vapor. Detection of such gases in the lunar atmosphere and the accurate measurement of their relative amounts will help us understand the chemical processes

that occur inside the Moon. Another major source of gas for the Moon is the Sun which ejects matter more or less continuously. This material spreads throughout the solar system and is termed the solar wind. The solar wind is very tenuous and moves with the speed of a few hundred miles per second. Perhaps you recall on earlier missions that we carried a sheet of aluminum foil (like the familiar household item used to wrap food) in which we actually trapped individual particles of the solar wind. The particles include atoms of many chemical elements such as hydrogen, helium, neon, argon, and so on. The particles of the solar wind strike the lunar surface, are neutralized, and are eventually released as a nonelectrically charged gas. Estimates of the composition of the solar wind and the losses of gas from the Moon's environment indicate that neon should be the most abundant gas of solar origin in the lunar atmosphere.

And finally there are many sources of gas created by man's exploration of the Moon—the rocket engine of each Apollo mission, the lunar roving vehicle, the liquids that are vented from the descent stage on landing, the ALSEP experiments, and even the astronauts themselves.

A slightly different mass spectrometer was carried in the CSM on Apollo 15 and 16. About 140 hours of data were obtained in lunar orbit and about 50 hours were obtained during the trans-earth coast. Many gases were clearly present. The data have not all been analyzed at the time of writing this booklet, and I cannot give you the final interpretation. But at first look, it seems that rather significant quantities of gas are in orbit around the Moon; there was also a decrease by a factor of 5 to 10 in the amount of gas measured during the trip back to Earth. We now believe that the liquids dumped from the spacecraft quickly froze and then continued to orbit the Moon with the spacecraft. Hence we are anxious to measure the atmospheric gases near the surface of the Moon.

### Lunar Ejecta and Meteorites Experiment (LEAM)

The Lunar Ejecta and Meteorite (LEAM) Experiment is designed to measure the direction of travel, speed, and mass of micrometeorites arriving at the surface of the Moon. A second major objective of the experiment is to measure similar

properties of any lunar particles that are ejected from the Moon by large meteorite impacts.

The basic sensor used in the LEAM experiment is shown in figure 37. An impinging dust particle travels through the front film where it produces an electrical pulse and impacts upon the rear film where it produces a second electrical pulse. From the time lapse between the electrical signals produced at the front and rear films, the particle's speed can be determined. From the speed of the particle and the amplitude of signals produced at the films, the mass of the dust particle can be determined. The front and rear films are each divided into 16 segments forming 256 basic sensors. The direction of travel is ascertained by relating the site (segment) of the front film impact to the site (segment) of the rear film impact. A microphone attached to the rear film plate independently (but in coincidence) measures a product of the velocity and mass of the particle and serves as a check on the other detection systems.

In setting up the LEAM, the astronauts must level it; set its orientation with respect to lunar north; and connect it to the ALSEP central station. The external appearance of the LEAM is shown in figure 38.

The existence of small dust particles in space has been known for many years. In passing through our Milky Way Galaxy, our Earth and solar system intercept clouds travelling at speeds greater than 50 miles per second. Another source of "cosmic dust" which impacts upon the Moon and upon Earth's atmosphere is debris from comets which partially disintegrate as they pass near the

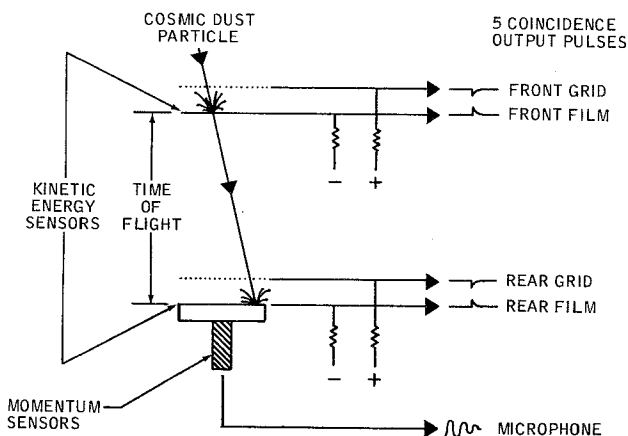

FIGURE 37.—Basic sensor of the LEAM experiment. See text for discussion.

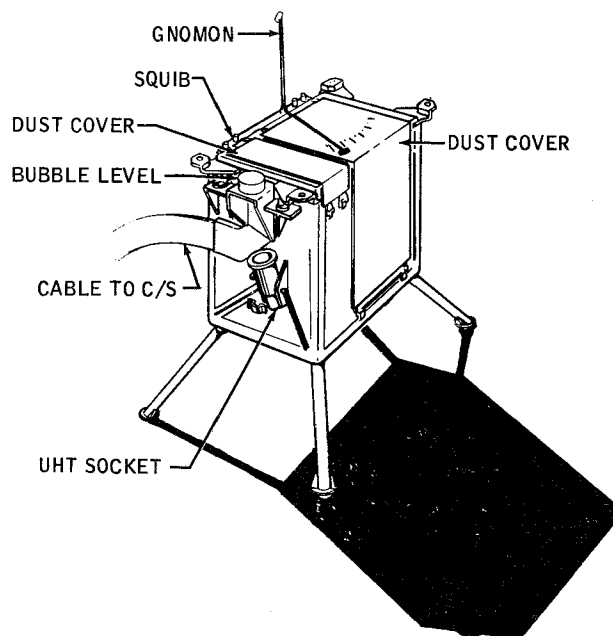

FIGURE 38.—Appearance of the LEAM equipment. The squib, a small explosives device, is used to "blow" the dust cover from the LEAM equipment after the astronauts leave the surface of the Moon.

Sun. The high altitude rocket research, started in the United States in 1949, used very sensitive microphones to detect meteorites striking the skin of the rocks. Hundreds of such measurements were made in the United States, the Soviet Union, and other countries. The conclusion drawn universally from those measurements was that an extremely high concentration of cosmic dust existed near the Earth. Indeed, in the period immediately preceding manned flight in space, some astronomers predicted that astronauts would have to become accustomed to the rather constant pinging that micrometeorites would make when striking their spacecraft. The early spacesuits were carefully designed to protect against such hazards, and accordingly, were very bulky.

We believe today, though, that the concentration of dust in space is considerably less. Why? Because more sophisticated measurements of the quantity of cosmic dust by an experiment onboard one of the unmanned spacecraft, Pioneer 8, revealed that the concentration of cosmic dust was at least one million times lower than indicated by early rocket measurements. We are very excited about the opportunity of performing micrometeorite impact studies on the lunar surface over a long period of time.

## Lunar Seismic Profiling Experiment (LSP)

The Lunar Seismic Profiling Experiment (LSP) is similar in principle to previous seismic experiments flown to the Moon but greatly different in design. The equipment consists of several geophones—really just electronic stethoscopes like the stethoscope used by doctors to listen to your heartbeat—with which to listen for sound waves in the Moon, eight packages of high explosives, and the necessary electronics equipment to control the experiment and to process the data for relay to Earth by the ALSEP central station. From analysis of the data we should detect any layers of rock beneath the surface of the Moon (to depths of 1 km.), measure the depths to them, and determine the velocity of sound in the rocks. Because sound waves travel with different velocity in dif-

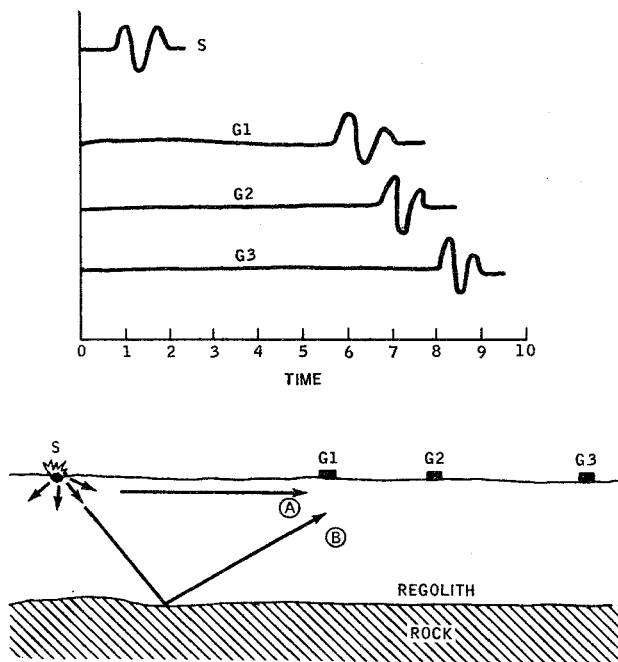

FIGURE 39.—Principle of the Lunar Seismic Profiling Experiment. The geometry of the experiment is shown in the lower figure. At the source, the explosion creates sound waves that travel in all directions. Some of these waves (marked A) travel in the direction of the three geophones, G1, G2, and G3. The relative times of the source and the arrivals at the three geophones are shown in the upper figure. In the actual case, the signals continue ringing longer than is shown in this figure; the signals have been abbreviated for clarity. If there is a layer of rock beneath the lunar soil, and the depth to it is less than 3 - 4 km., then some of the elastic energy (marked B) is returned to the surface. Such waves arrive at the geophones later than the direct waves.

ferent kinds of rocks, we can even infer the kinds of rock present in the subsurface!

The principle upon which this experiment is based is indicated in figure 39. The sound waves produced at the source travel through the lunar soil and rock to the geophones. The geophones "hear" the sound waves and send them over the ALSEP telemetry link to Earth. The time of the source explosion and the times at which the waves arrive at each geophone are measured precisely. The velocity of the waves in the lunar soil is obtained by dividing the distance from the source to each geophone by the time required for the waves to travel. Note that both distance and time must be known accurately. We expect to measure the distance to each explosive package to a few meters. The electronic circuits will provide times that are accurate to two-thousandths of a second.

Any layers of solid rock at Taurus-Littrow will reflect some sound energy towards the surface. The reflected waves travel farther than the direct waves and so arrive at each geophone later; and their electrical signals are sent to Earth also. From the amount of time required for the reflected waves to arrive at the geophones, (and the velocity of travel obtained from the direct wave), we can determine the depth of the reflecting surface.

This technique is a modification of one that is used very extensively on Earth by industry to search for oil and gas.

The explosives source is extremely interesting. I am sure that you appreciate the immense concern of everyone for the safety of the astronauts. After all, even the  $\frac{1}{8}$  pound charge, if detonated prematurely, *could* be disastrous to the mission. I personally believe that the LSP explosive package is completely safe. NASA's safety engineers agree with me.

In figure 40 the explosive package is shown schematically. The three rings marked "Astronaut Pull Ring" are pulled by the astronaut when the package is set in place on the Moon. Each of these rings controls independent safety devices inside the package; all three events must occur for the explosives to be detonated. One of the rings starts a timer that runs for approximately 90 hours, at the end of which the explosives may be detonated. The second ring controls a sliding plate that is used to physically prevent the detonator from exploding the main charge. The third ring controls a timing mechanism which activates a battery energizing the explosive package. The activated bat-

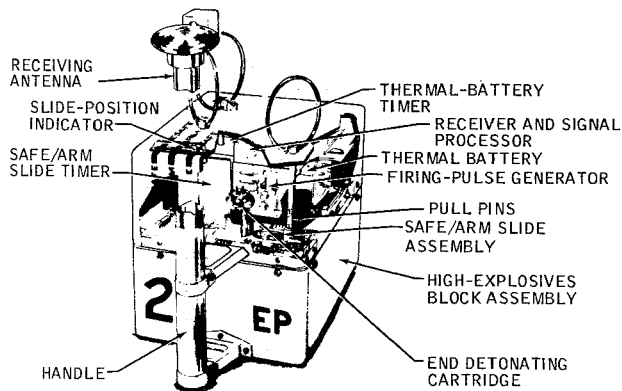

FIGURE 40.—The Lunar Surface Profiling Explosives Package. This package contains high explosives in the lower compartment and extensive safety devices in the upper compartment. Three independent events must occur simultaneously *after* the three safety rings are pulled for the charge to be detonated.

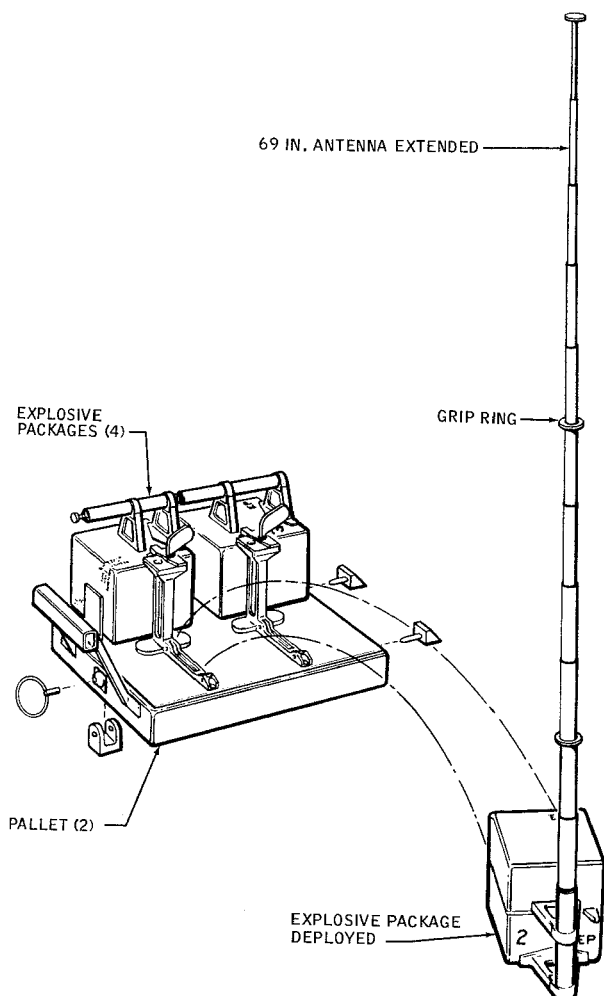

FIGURE 40B.—Lunar Seismic Profiling Packages on Pallet. Four packages are stowed on each pallet. As each package is removed and placed on the Moon, the antenna is extended and the three rings are pulled.

tery provides electrical energy to the receiver and firing circuitry for one minute. Only then can the package be fired by a radio signal sent from the Earth to the LSP Transmitter. Thus three independent events are required for a package to explode: (1) the sliding timer must move the slide to a firing position, (2) the battery timer must activate the battery before the slide moves to a "safe" position, and (3) the radio signal to fire must be received and processed within a 1 minute "time window." And finally, if the unit is not detonated within 2 hours of the correct time, then the sliding plate will move to a "resafe" position. A visual indicator which can be seen on the upper left hand part of the case (figure 40) will indicate that the unit is again "safe."

On EVA Nos. 1, 2, and 3, the astronauts will carry with them the explosives packages for the LSP. They will place the explosives packages at eight selected spots along the traverses and shown in figure 41. The packages with smaller amounts of explosives will be placed near the ALSEP site, those with larger amounts will be placed farther from the ALSEP site. Then approximately 90 hours after each explosives package has been armed—and the astronauts are on their way home—each explosive package will be detonated. We expect to see the explosion of the nearby charges with the TV camera which should continue to operate for a few days after lift-off. The planned sequence of firing the individual packages is shown below.

Charge size (lb)	Charge number	Distance from ALSEP (km.)	Time after deployment to detonation (hour)	Time after liftoff to detonation (hr:min)
1	6	1.3	91	24:18
3	5	2.0	92	26:52
1/2	7	.8	93	28:08
1/8	4	.16	91	43:23
6	1	2.4	92	48:45
1/4	8	.25	94	51:40
1/4	2	.25	93	74:42
1/8	3	.16	94	75:46

### Lunar Geology Experiment (LGE)

Most of the time spent by the *surface* astronauts during the three EVA's will be devoted to investigating various geologic features at the landing site

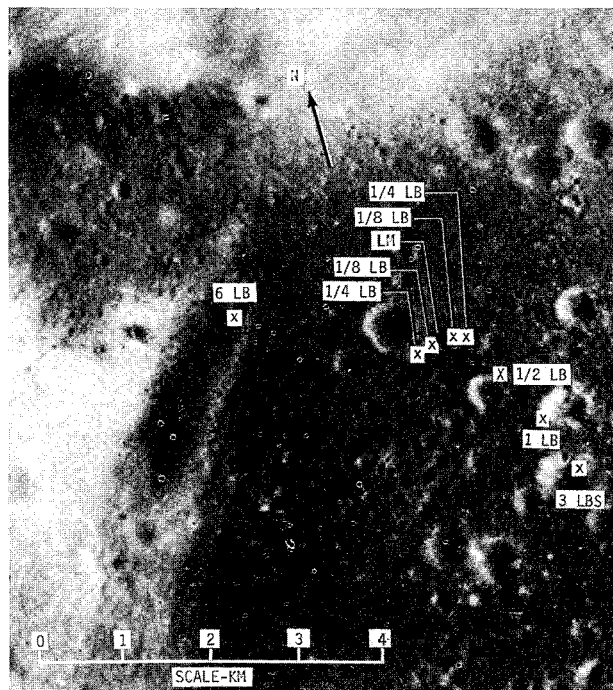

FIGURE 41.—Location of Lunar Seismic Profiling Experiment explosive charges.

and to collecting samples of rocks. Many detailed photographs will be obtained to supplement the verbal descriptions by the astronauts. Samples of the rocks present at the site will be bagged and brought back to Earth. The astronauts will use several individual pieces of equipment to help them with their tasks. In this section, I describe briefly the goals of the experiment as well as the individual items used to study the geology of the Taurus-Littrow region and to collect samples for return to Earth.

Lunar geologists have as their goal the reading of the historical record of the Moon for the past 5 billion years. That record has been preserved in the lunar rocks. One part of it is seen in the shape of the outer surface of the Moon. Another part is present in the distribution of different kinds of rocks over the surface of the Moon. And still a third part is given by the nature of the lunar interior. At the Taurus-Littrow site, we plan to study thoroughly several features. Rocks produced by the event that caused the Serenitatis Basin will surely be present. They should provide the information needed to read an important chapter in lunar history. Many samples will be collected at the landing site. After the samples reach Earth, they will be studied extensively by nearly

eight hundred scientists all over the world. The minerals present in them will be identified. The ages of the rocks will be read from their built-in radioactive clocks. Such physical properties as thermal expansion, velocity of sound waves, electrical conductivity, and many others will be measured. The value of all these measurements is greatly increased by knowing the geologic setting of the rocks. To provide the details of that geologic setting is one function of the Lunar Geology Team led by Prof. William Muehlberger. They use the observations made by the astronauts. They study the rocks brought back to Earth and relate them to the things on the Moon they can see through high-powered telescopes. And they restudy the existing lunar photographs in relation to the rocks. Another function, of course, is to integrate the knowledge obtained from study of the Taurus-Littrow site into the geological understanding of the whole Moon.

In the process of collecting rocks for the geologic experiment and for the investigations on Earth, several items of equipment are used. Let's discuss them.

On the first few Apollo flights, the astronauts, soon after they had first set foot on the Moon, collected a small (1-2 lbs.) sample of rock and soil. It was appropriately termed contingency sample. It was stowed onboard the LM immediately so

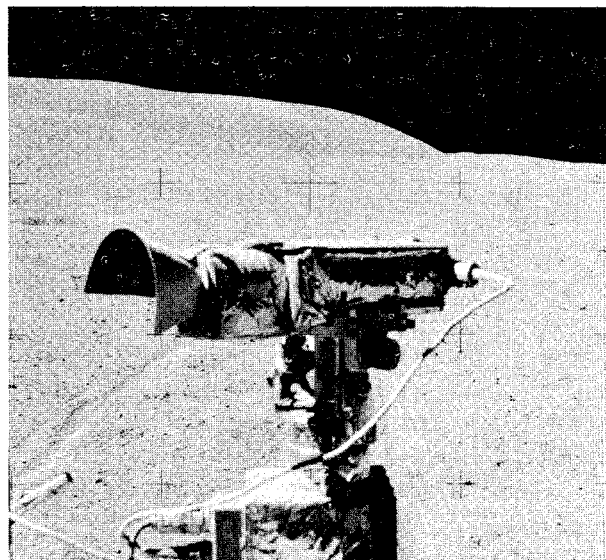

FIGURE 42.—Apollo 16 television camera. A similar camera will be carried onboard Apollo 17. After the Rover is placed in operation the TV camera will be mounted on it. The camera is controlled from Mission Control in Houston. NASA PHOTO 16-117-18754.



APOLLO 16 TV PANORAMA  
FROM RIM OF FLAG CRATER  
EVA 1  
STATION 1

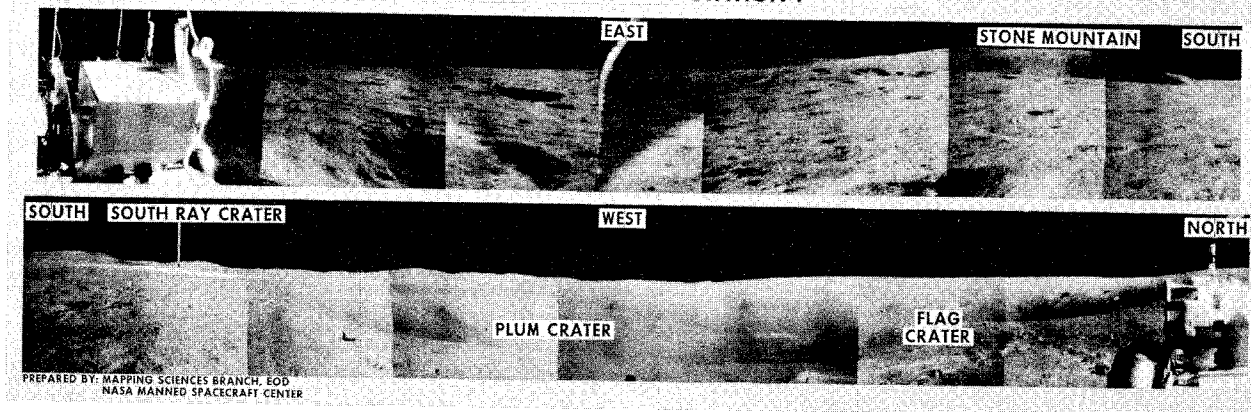

FIGURE 43.—Apollo 16 television panorama. This panorama was made from photographs of the television screen taken during Apollo 16 EVA 1. The TV camera was located on the rim of Flag Crater. You could have made a similar panorama from photographs taken of your own television set. NASA PHOTO S-72-35970.

that at least some material would have been obtained if the mission had had to be ended abruptly. A special collecting tool was used. On Apollo 16 though, we did *not* collect such a sample in order to save both time and weight. Neither do we plan to collect one on Apollo 17. Instead we plan to collect this sample only if the mission is aborted early in the first EVA. One astronaut carries a regular sample bag in his pocket. If it becomes apparent that the mission is likely to be aborted, then he will quickly fill the bag and stow it in his pocket for return to the LM. Perhaps the contingency sample provides the best illustration of our desire to obtain the most “science” during the stay on the Moon. You might think that the 5 minutes and 1-pound-tool needed to collect the sample are both very small. And they surely are. But we believe that our new “if-needed-procedure” will give us the same insurance against returning with no sample and also give us an additional 5 minutes to collect other, more valuable samples.

Observations made on the lunar surface of the various geological features are very important. The TV camera allows us on Earth to follow the astronauts and to “see” some of the same features, though not nearly so well as the astronauts see them. A photograph of the Apollo 16 TV camera, similar to the one on this mission, is shown in figure 42. The TV camera will be mounted on the Rover during the traverses. Its location can be seen in figure 15. The value of the TV camera to the scientists working on Apollo 17 is very great because they can follow the actions of the astro-

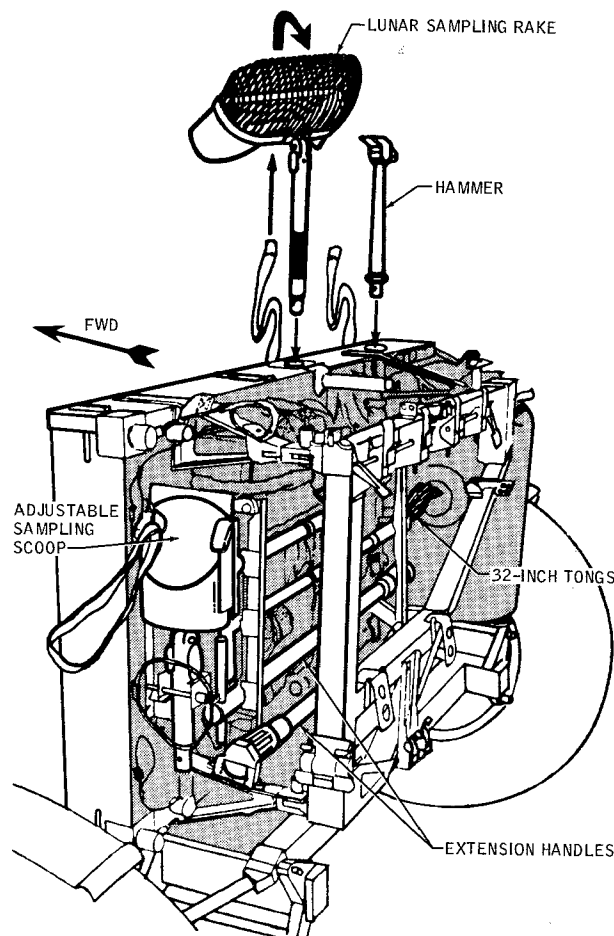

FIGURE 44.—Lunar Geological Hand Tools. This equipment is used to collect samples of rock and soil on the Moon. The frame is mounted on the Rover. See text and subsequent figures for details.

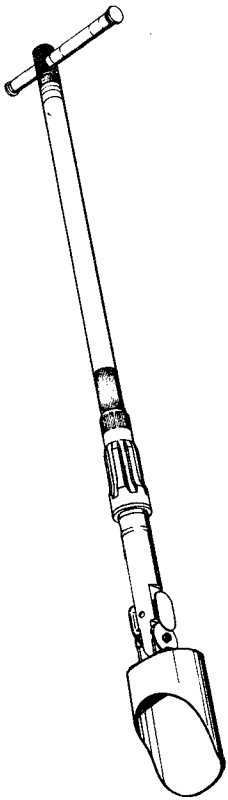

FIGURE 45A.—Scoop with extension handle. Its use in Appollo 12 is shown in figure 45B.



FIGURE 46.—Tongs shown in use on Apollo 12 to collect a small rock. NASA PHOTO S-71-31075.

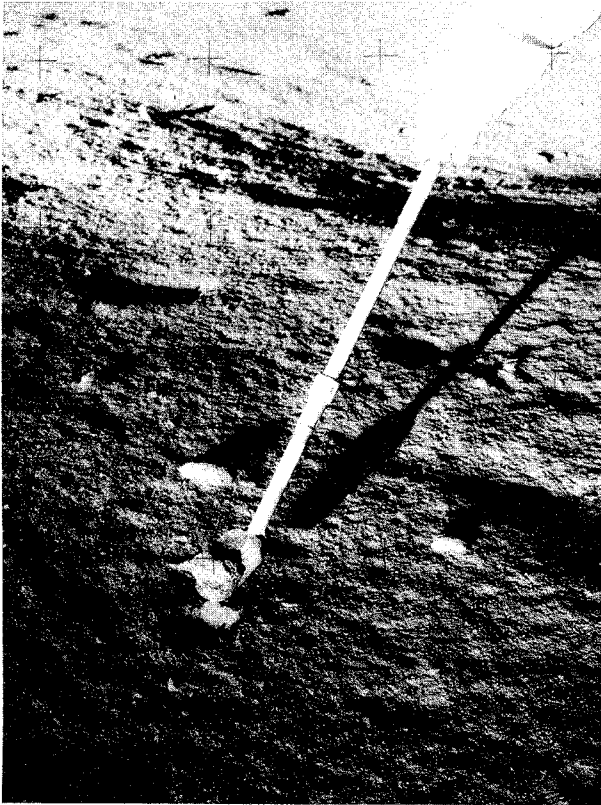

FIGURE 45B.—Note the small rock in the scoop. NASA PHOTO AS12-49-7312.

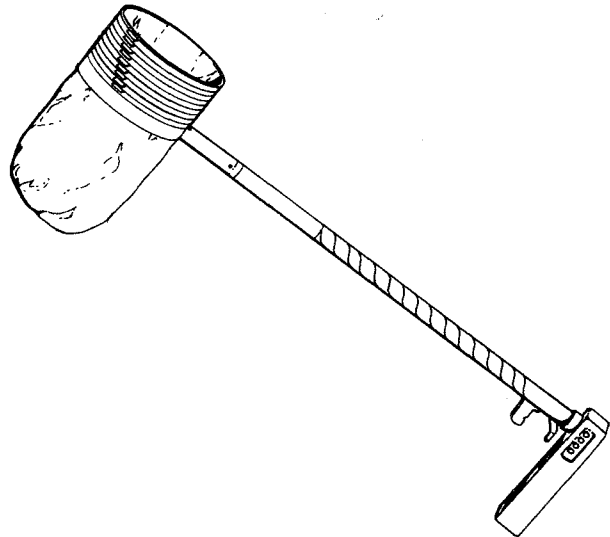

FIGURE 47.—LRV Sampler. This tool will be used by the astronauts to collect samples of the Moon while seated on the Rover. The tool contains several nested bags. As each bag is used, it is removed and stowed. NASA PHOTO S-72-50308.

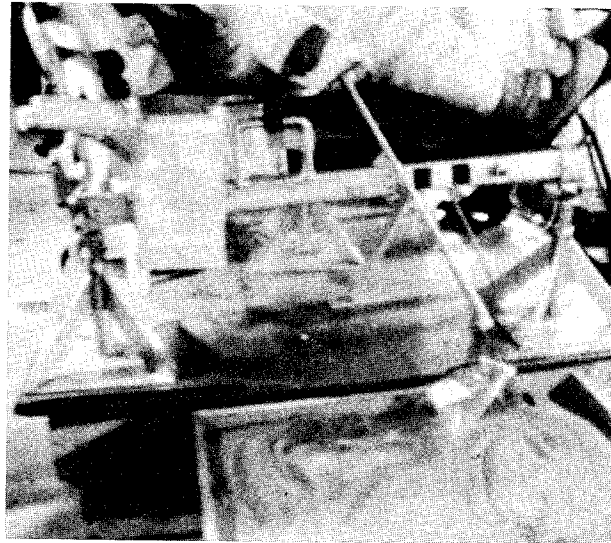
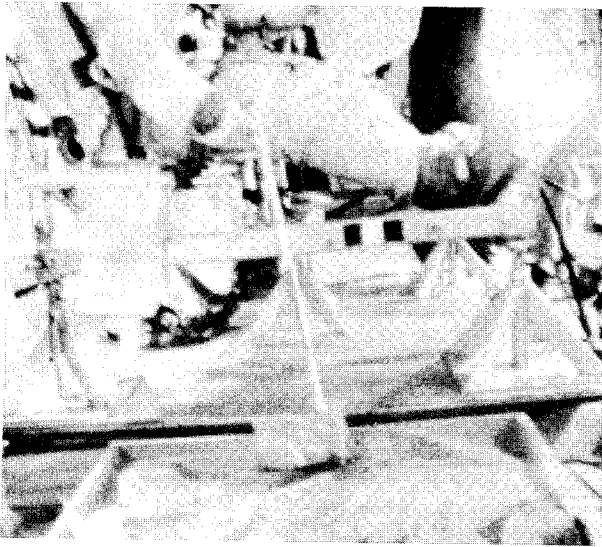
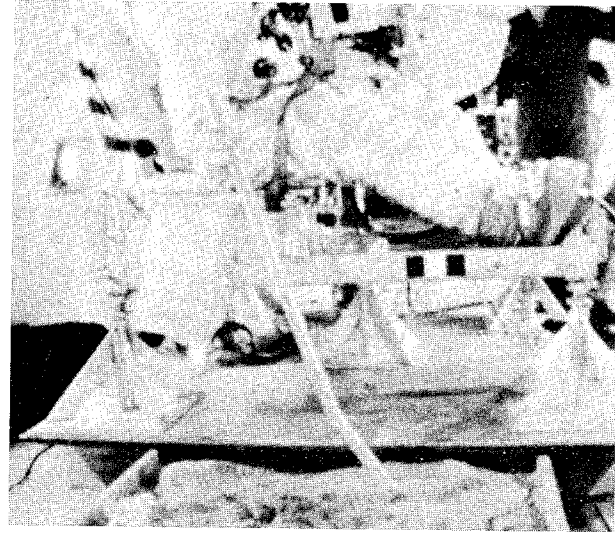
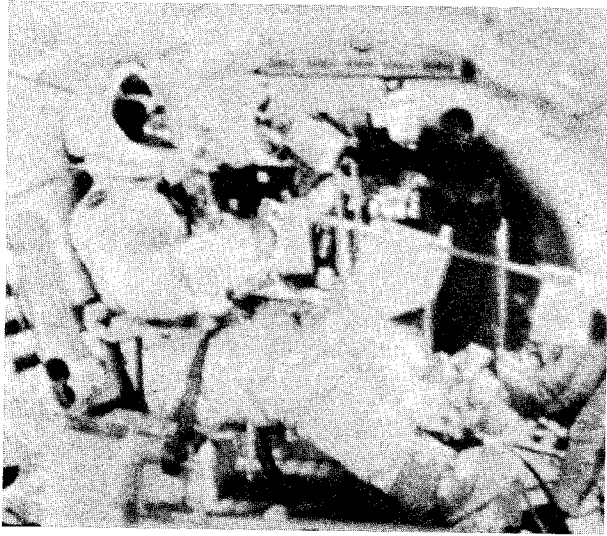

FIGURE 48.—Testing the LRV-Sampler in one-sixth gravity. The airplane flies arcs to balance the Earth's gravity. Several early designs of the LRV-Sampler were tested by Schmitt for ease of use and performance. Note the mocked up parts of the Rover. NASA PHOTO.

nauts, they can observe and photograph through the TV system features that may be missed by the crew, and they can *see* the site—rather than just *hear* it described. The quality of the images is shown in figure 43, an Apollo 16 panorama made from photographs of the TV screen.

Other tools used by the astronauts, together with an aluminum frame for carrying them, are shown in figure 44. The hammer is used to drive core tubes into the soil, to break small pieces of rocks from larger ones, and in general for the same things that any hammer might be used on Earth.

Because the astronaut cannot conveniently bend over and reach the lunar surface in his space suit,

an extension handle is used with most tools. The scoop (figure 45) is used to collect lunar soil and occasionally small rocks. The tongs, shown in figure 46, an Apollo 12 photograph, are used to collect small rocks while the astronaut stands erect.

Another sample collecting tool, to be used for the first time on Apollo 17, is termed the LRV-Sampler. It is shown in figure 47. With it, the astronaut can collect samples from the Rover without getting off. As we plan to use this tool on the Moon, the driver stops the Rover momentarily while the other astronaut scoops material from the Moon. The Rover then proceeds along the traverse. This tool has not been used before on the Moon

but it has been tested thoroughly (like the other tools and equipment used previously). Shown in figure 48 is one such test being done in  $\frac{1}{6}$  gravity. By flying an airplane (a KC 135 in this instance) in an upward arc, we can partially balance the Earth's gravity field and simulate for about 30 seconds the Moon's gravity. The effect is similar to that felt when an elevator traveling upward stops.

The drive tubes (figure 49) are used to collect core material from the surface to depths of 1 to 3 feet. The core remains in the tubes for return to Earth. Preservation of the relative depths

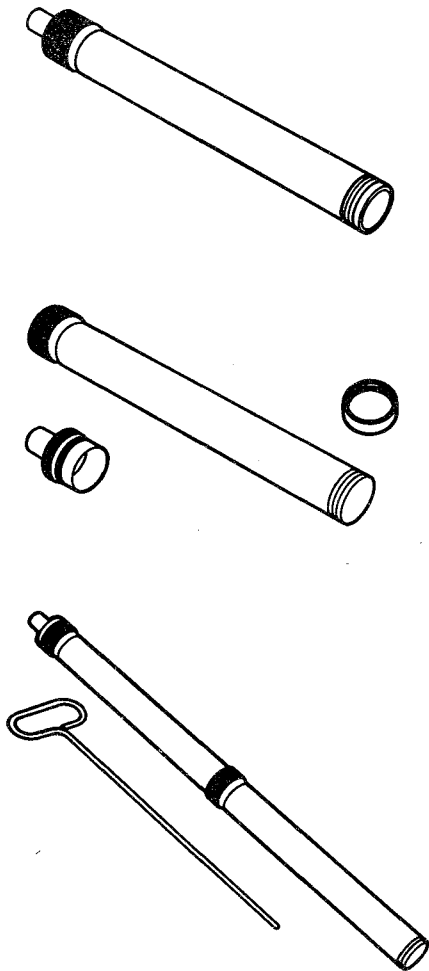

FIGURE 49.—Drive Tubes. These tubes, about 18 inches long, are pushed or driven into the lunar surface to collect samples as a function of depth. A single tube is shown in the top of the figure, a double tube at the bottom. Two or even three of them may be joined together to obtain a longer core. Their use in Apollo 14 may be seen in figure 50.

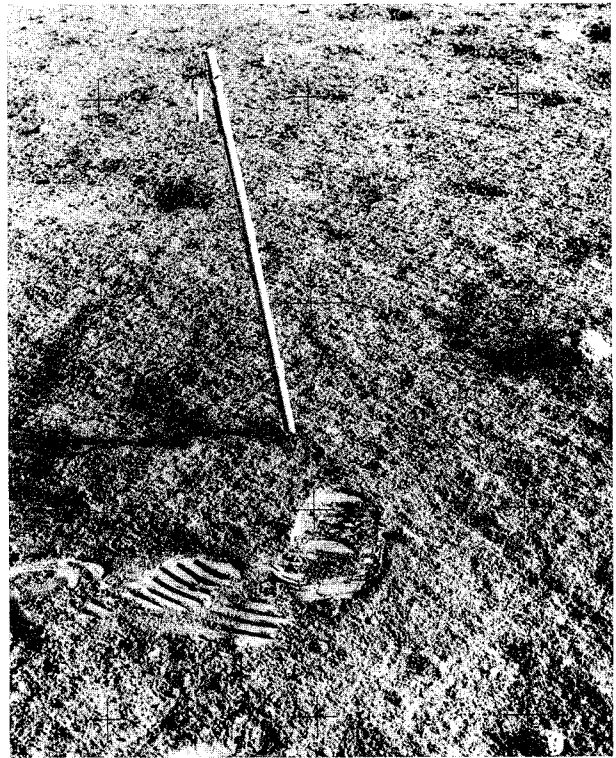

FIGURE 50.—Drive tube in lunar surface at Apollo 14 site. The relative difficulty of driving the tube into the surface is an indication of the strength of soil. Note in addition the footprints, rocks, and small craters. NASA PHOTO S-71-31082.

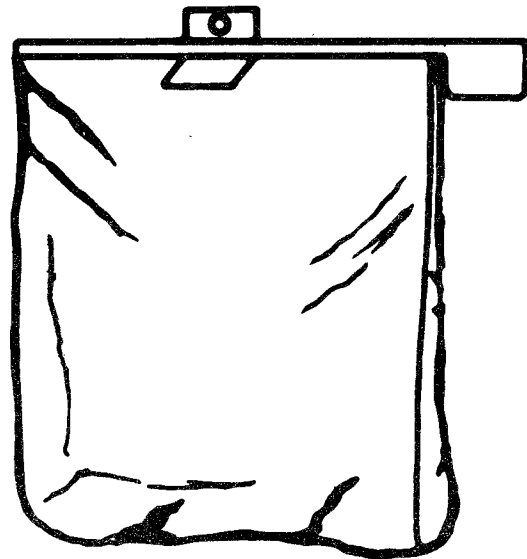

FIGURE 51.—Lunar sample bag. The bag resembles the familiar kitchen item "Baggies." It is made of Teflon. A strip of aluminum is used to close the bag. Each bag has a number printed on the aluminum strip for identification.

of the core material is especially important. The drive tubes were originally suggested about 7 years ago by the late Dr. Hoover Mackin, a geologist. Shown in figure 50 is a drive tube that was driven into the Moon's surface on Apollo 14.

After the surface samples are collected, they are placed in numbered sample bags made of Teflon (figure 51). Most of us know Teflon as the "won-

der material" that coats kitchen pots and pans to prevent sticking. It is used for our sample bags chiefly because it contains no objectionable foreign material (such as lead) that would contaminate the samples, can be made readily into bags, and has certain desirable vacuum characteristics. These bags are about the size of the familiar kitchen storage bags for sandwiches. After a sample is bagged, the thin aluminum strip is folded to close the bag and prevent the samples from becoming mixed with others. The bags are finally placed in the sample return containers, sketched in figure 52, for return to Earth. The Apollo Lunar Sample Return Container (ALSRC) is about the size of a small suitcase. It is made of aluminum and holds 20 to 40 lbs. of samples. You will likely hear it called the *rock box*.

On each mission, the astronauts collect some rocks that are too large for the regular bags. You may remember the words of Apollo 12 Astronaut Pete Conrad, "Oh boy, I want that rock. There is a dandy extra grapefruit-sized-type goody. Man, have I got the grapefruit rock of all grapefruit rocks." That particular rock was not brought to Earth but rolled down a crater wall in another experiment. On Apollo 17, such large rocks will be placed in big bags that are made of Teflon also. For the journey to Earth, these big bags are to be stowed in various places in the CM cabin.

A special container, termed Special Environmental Sample Container (SESC), is used to col-

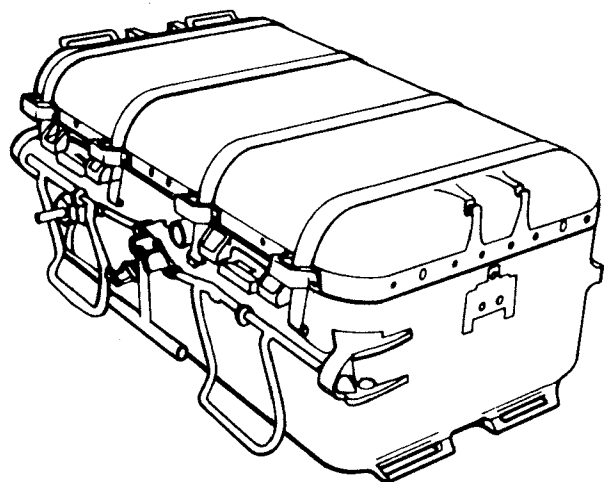

FIGURE 52A.—Apollo Lunar Sample Return Container. Made of aluminum, this box is used to return Lunar samples to Earth. It is about the size of a small suitcase but is many times stronger. The ALSRC has changed very little since it was first used on Apollo 11. It is affectionately nicknamed the "rock box." NASA PHOTO S-72-49032.

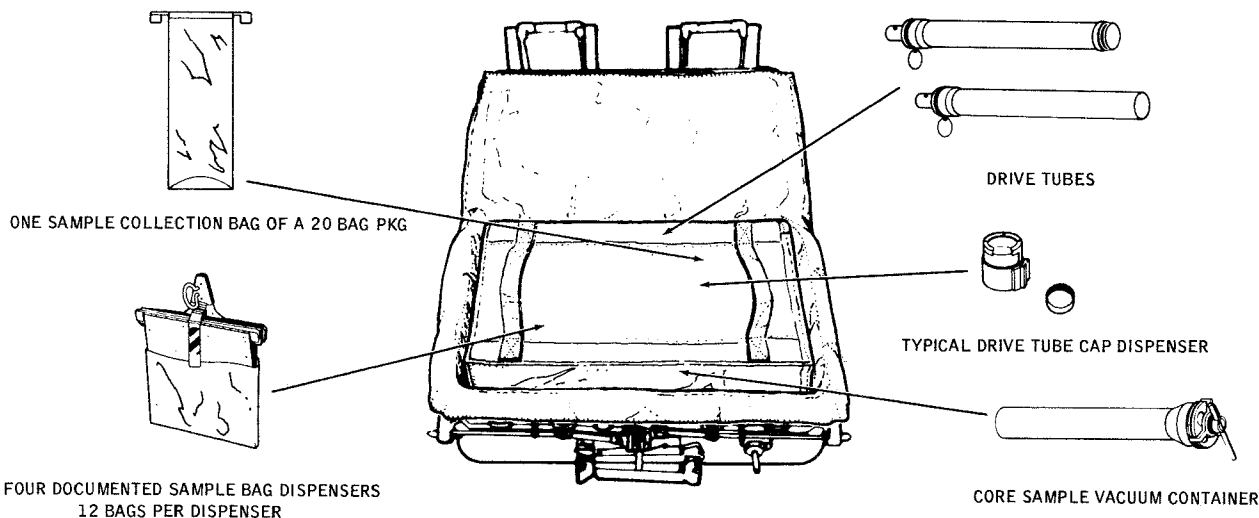

FIGURE 52B.—Apollo Lunar Sample Return Container. Various items are packed in each of the rock boxes for the journey to the Moon. Shown in this sketch are those items contained in one of the rock boxes on Apollo 17. NASA PHOTO S-72-49031.

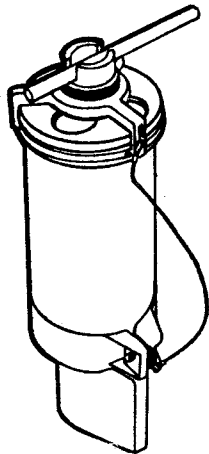

FIGURE 53A.—Special environmental sample container. This container has special vacuum seals to prevent gases and other materials from entering the container and being adsorbed on the surfaces during the journey to the Moon. They also prevent contamination of the samples by rock exhaust gases and the Earth's atmosphere during the return journey.

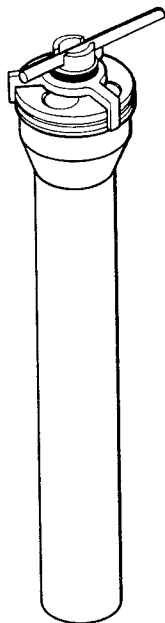

FIGURE 53B.—Special environmental sample container for core tube. This model is about twice as long as the other version. It will be used to store a drive core tube for return to Earth under vacuum conditions. It is our hope to preserve this sample completely uncontaminated. NASA PHOTO S-72-49042.

lect material on the surface of the Moon for specific purposes. (See figure 53.) This container has pressure seals to retain the extremely low pressures of the Moon. It is made of stainless steel. On Apollo 17, one drive core sample will be returned in an elongated version of this container. This sample will be collected in such a manner that it will have very little contamination with either organic or inorganic materials from Earth. The largest sources of biological contamination are the astronauts themselves; the suits leak many microorganisms per minute and the lunar rocks collected on previous missions have all contained some organic material (a few parts per billion). I believe it unlikely that *any* of the organic material present

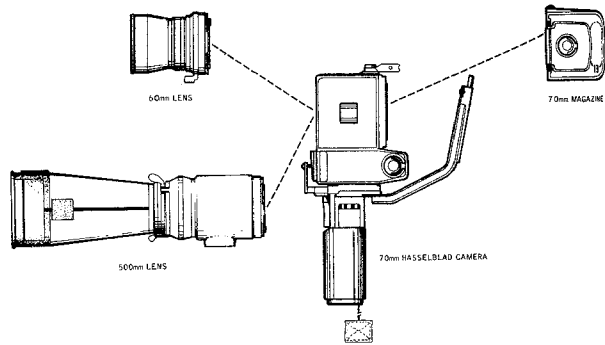
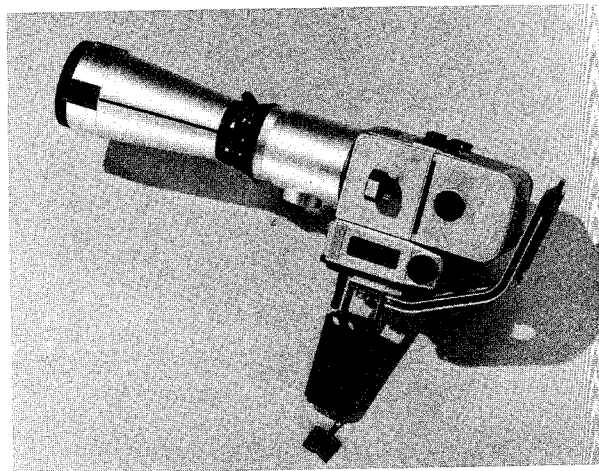

FIGURE 54.—Hasselblad camera. The film, which may be black and white or color, is 70 mm wide. The camera is electrically operated. NASA PHOTO.



on the Moon before the astronauts' landing was biologically formed but some researchers would disagree with me. This question is still being intensely investigated.

The Hasselblad cameras used by the astronauts (figure 54), although very similar to the ones available in camera stores, were especially adapted for use on the Moon. (Many photographs of the Moon have been obtained already. Representative sets of Apollo photos as full color lithographs suitable for framing can be purchased from the Superintendent of Documents, Government Printing Office, Washington, D.C. See bibliography, page — for descriptions of the sets available.) The film is 70 mm. wide, exactly twice as wide as the familiar 35 mm. film. The color film is similar in characteristics to Ektachrome-EF daylight-type. The black and white film has characteristics like Plus X. The primary purpose of the cameras is that of documenting observations made by the astronauts. Especially important is the careful documentation of rocks that are collected for study

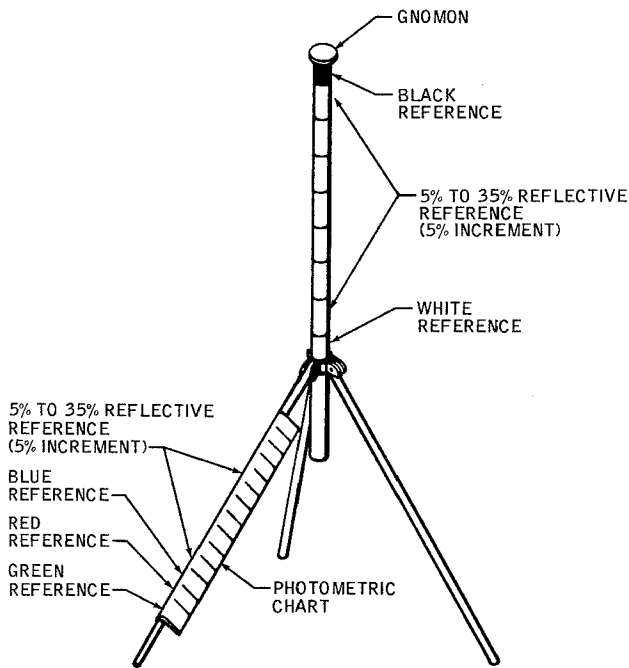

FIGURE 55.—Gnomon. This device is used to provide a physical scale and to calibrate the photometric properties of the samples on the Moon. It can also be seen in figure 56, an Apollo 14 photograph. The long central rod swings freely and indicates the vertical. Its shadow is used to determine direction from the known position of the Sun. NASA PHOTO 72-49042.

back on Earth. Ideally, several photographs are taken of each rock: (1) before collection with the Sun towards the astronaut's back, (2) before collection with the Sun to the side of the astronaut, (3) before collection a third photo to provide a stereo pair, and (4) after collection a single photo to permit us to see clearly which sample was collected. A device, termed gnomon, and illustrated in figure 55, is included with these pictures to provide a scale with which to measure size and a calibration of the photometric properties of the Moon's surface. In addition to these photographs, a fifth one is desirable to show the general location of the sample with respect to recognizable features of the lunar surface. An example from Apollo 14 is seen in figure 56. The photos taken before collection and after collection show clearly which rock was removed.

At all stations, still more documentation is desirable. Panoramic views are obtained by shooting many photographs which include the horizon while turning a few degrees and sidestepping one or two paces between snapping each successive

photo. The photos have considerable overlap. After return to Earth, the overlap is eliminated and the photos pieced together to yield a composite view of the Moon's surface as seen from a particular spot. The composite photo is usually called a pan, short for panoramic view. One example from Apollo 16 is shown in figure 57. Others from Apollo 14 and 15 may be seen in the July 1971 and February 1972 issues of National Geographic Magazine. In addition, the overlapped regions are used for stereoscopic viewing of the surface. Truly three-dimensional views are obtained in this way. An example of such a stereo pair is shown in figure 58.

Marble-sized rocks from the Moon have proven to be especially valuable in lunar science. They are large enough to allow an extensive set of measurements to be made, yet small enough that many of them can be collected. Accordingly, we designed and built a tool and used it on Apollo 15 and 16 to collect many such samples. It is termed a rake, although the resemblance to the familiar garden tool is now slight. It is illustrated in figure 59 and 60. We expect to use it again on Apollo 17.

The Apollo Lunar Surface Drill (ALSD), used to drill the two holes for the heat flow experiment and illustrated in figure 30, is used also to drill a third hole from which the samples are saved. The drill bit for this purpose is hollow and allows rock and soil to pass into the hollow drill stem. These samples, referred to as core, are about  $\frac{3}{4}$ -inch in diameter. Individual pieces of rock are likely to be button-shaped and  $\frac{1}{4}$ -inch thick. A few pieces may be larger. Most of the material will probably consist of lunar soil. These samples should not be confused with the samples obtained with the drive tubes which are also termed core. This equipment can drill and collect solid rock, if any is encountered, whereas the drive tubes can collect only material that is small enough to enter the tube. After the hollow drill stem has been drilled 10 feet into the Moon, friction along the sides makes its removal by hand very difficult. Thus the astronaut uses the core extractor sketched in figure 61 to pull the drill stem with its precious contents from the hole.

### Soil Mechanics Experiment (SME)

The mechanical properties of the lunar soil are important for both engineering and scientific reasons. Future design of spacecraft, surface vehi-

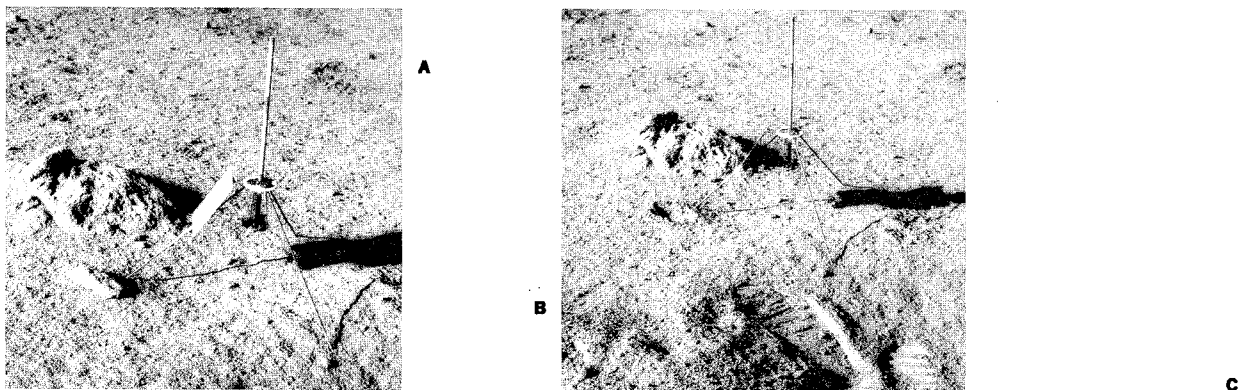

FIGURE 56.—Photographic documentation of lunar samples. These three Apollo 14 photographs indicate clearly the method used to identify the rocks that were collected. The shadows in A, together with knowledge of the time that the photo was taken, have been used to orient the specimen. A location photo (not shown) allows us to determine the relative location of this sample with respect to others collected during the mission. Photo A was taken before the rock was collected. Photo B was taken after collection. Photo C was taken in the laboratory after the Apollo 14 mission had returned to Earth. The field geology team led by Dr. Gordon Sivann, identified the rock in photos A and B as sample 14306 and deduced from photo A the orientation on the lunar surface. NASA PHOTO S-71-31077, AS14-68-9462.

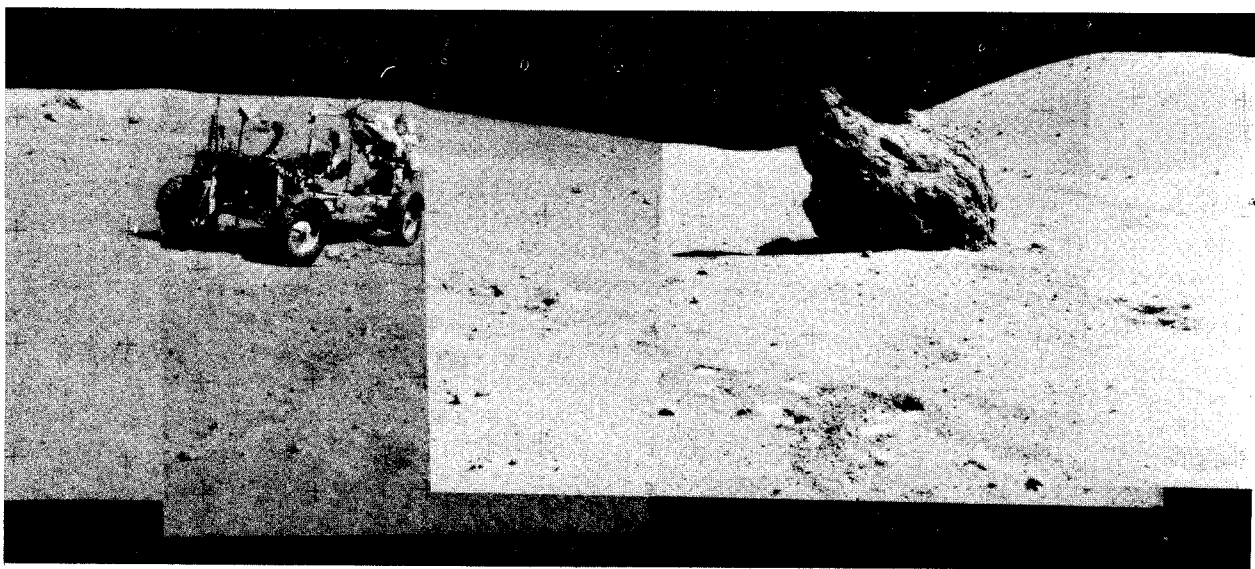
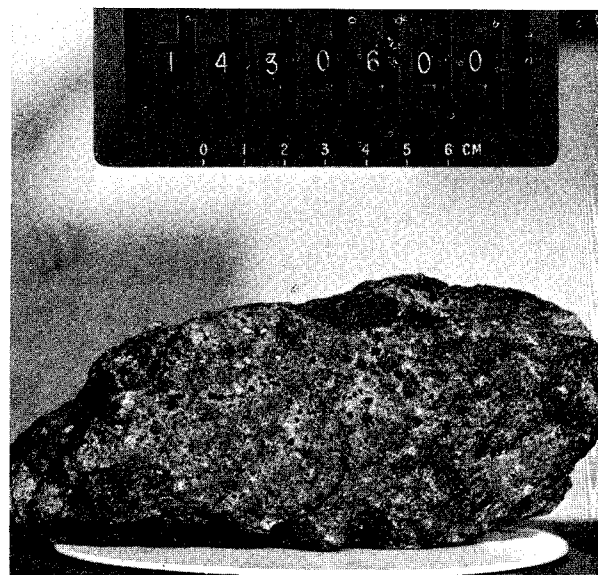

FIGURE 57.—A portion of a panoramic view obtained on Apollo 16. The method of piecing together several photos is clearly shown. Also, the difficulties of fitting the edges of the photos can be imagined from the mismatches evident here. Panoramas from Apollo 14 may be seen in the July 1971 issue of National Geographic magazine. Note the tracks of Rover and the astronaut footsteps. NASA PHOTO S-72-38175.



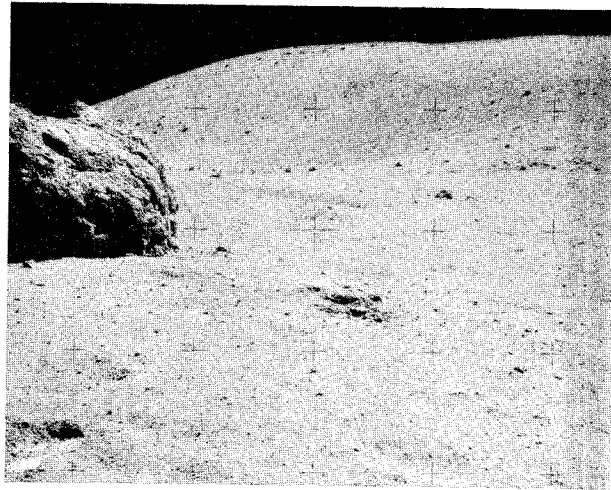
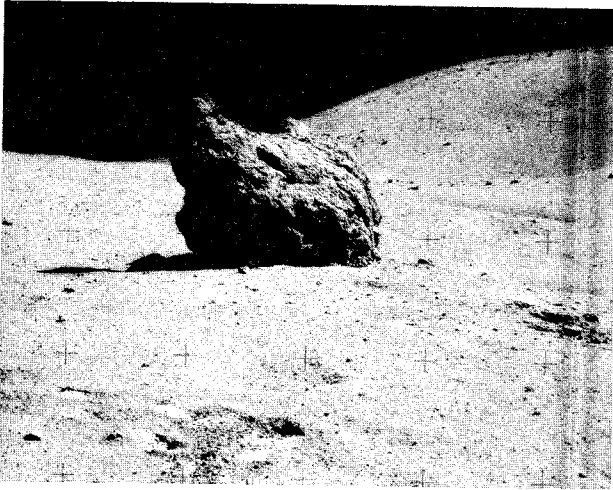

FIGURE 58.—Apollo 16 stereo photographs. The same photographs used to produce figure 57 were used for this figure but here we used the overlapping parts that were eliminated to make the panoramic view. See figure 8 for instructions on stereo viewing. NASA PHOTOS AS-16-106-17393 and -17394.

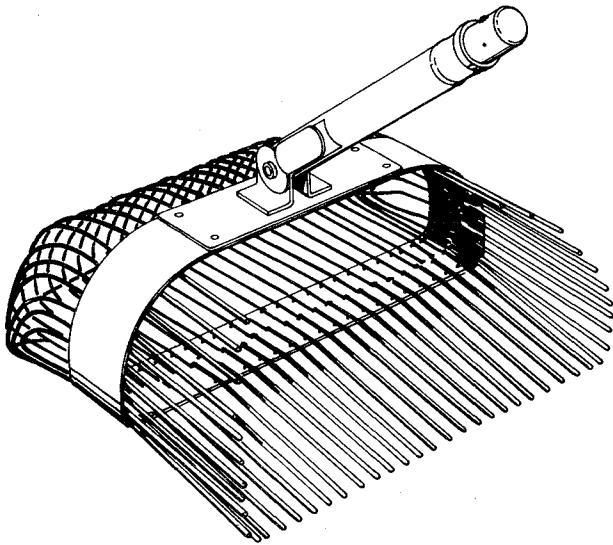

FIGURE 59.—Rake. This tool was used on Apollo 15 and 16 to collect marble-sized rocks. It will be used again on Apollo 17.

cles, and shelters for use on the Moon will be based, in part at least, on the data collected in the soil mechanics experiment of this mission. From previous missions we have learned that the mechanical properties are generally similar to those of terrestrial soils of comparable particle size. Indeed, the distributions of particle sizes and particle shapes, together with the density of the soil seem to control the physical properties. Densities of soil on the Moon range from 1.0 to 2.0 gm/cm<sup>3</sup>,

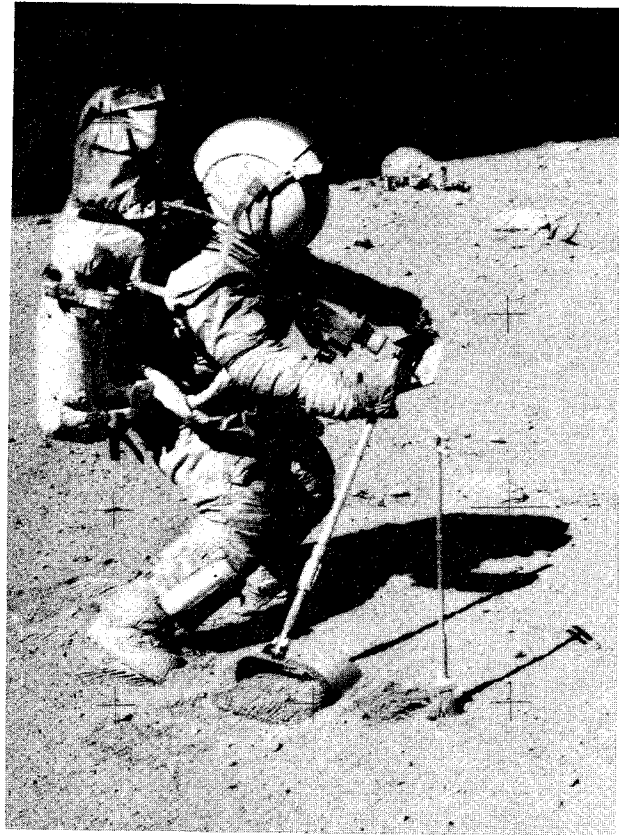

FIGURE 60.—An Apollo 16 astronaut is shown here using the rake during his visit to Descartes. The tongs are seen standing upright. NASA PHOTO AS16-106-17340.

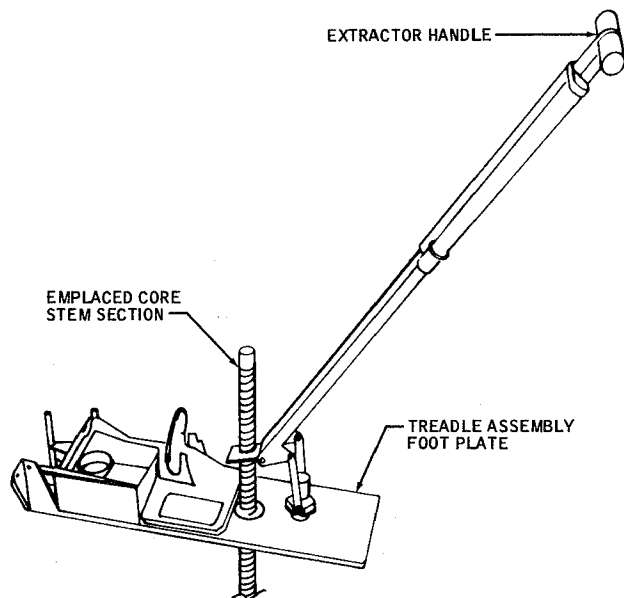

FIGURE 61.—Core stem extractor. After the hollow core stem has been drilled to a depth of about 10 feet, the drill head (shown in figure 30) is removed. The treadle is then moved to the position shown here and the extractor is used in a fashion similar to that of an automobile bumper jack to pull the core stem from the Moon. NASA PHOTO S-72-50284.

even though the individual particles average about  $3 \text{ gm/cm}^3$ . The porosity (the fraction of open spaces in the soil) of the outer few cm of soil averages about 40 percent at the previous sites. The strength of the soil varies from 2 to 20 pounds per square foot.

On Apollo 17, no special equipment for the SME will be carried to the Moon. This experiment is completely passive and the data will be obtained indirectly from observations and photographs made during the performance of other experiments. The astronauts have been alerted to watch specifically for such features as layering in the soil, surface patterns, slight changes in color, and the presence of fillets (the accumulation of soil against boulders).

Footprints on the Moon also provide data on the soil. Indeed, John Havland, Jim Mitchell, and William Houston, three scientists who study the lunar soils—have said that “every step taken by the astronauts on the Moon is a step for soil mechanics, provided the footprint is photographically documented.” The weight of the astronaut (plus any load) on the Moon and the characteristics of his footprint can be readily interpreted in terms of the physical properties of the lunar soil. So can similar information from the Rover

tracks. Such other items as the quantity of dust blown from the Moon by the exhaust from the descending LM, the depth to which the LM footpads sink, the amount of dust thrown up by the wheels on the Rover while traveling, and the depth of trails left by boulders that rolled down slopes, are all important factors in estimating the properties of the lunar soil. And of course, the cores (from the drive tubes and the deep drill core) provide direct information on the nature of the lunar soil. Several figures in this booklet show examples of these data from earlier missions; see especially the drive tube and foot prints in figure 50 and the Rover tracks in figures 42 and 57.

### Surface Electrical Properties Experiment (SEP)

The Surface Electrical Properties Experiment (SEP) uses radio waves to “see” down into the Moon in much the same way that a doctor uses X-rays to “see” broken bones. We may be able to see into the Moon as deeply as a few kilometers. Several colleagues and I have worked on this experiment for several years in anticipation of using it on the Moon. It is an entirely new experiment and has never been used for the exploration of the Earth.

With SEP, we will look for layering in Taurus-Littrow’s rocks and soils. We will look for large boulders that are completely buried and cannot be seen by the astronauts. We will even look for water in the subsurface—though we do not expect to find any. Our experiment will be carried on the traverses of the second and third EVA’s.

The SEP equipment is rather simple in concept. We use a radio transmitter to generate radio signals that are extremely stable, a dipole antenna\* that is laid on the Moon’s surface by the astronauts, and a radio receiver that is carried on the rear of the Lunar Rover. The actual data are recorded on a tape recorder which is similar to the home-style cassette tape recorders and which is brought back to Earth by the astronauts. The

\* Dipole antennas are familiar to most people in the form of “rabbit ear” antennas used with home TV sets. By extending the two arms along a straight line, you produce a true dipole antenna. The SEP antenna differs chiefly in length. It is 70 m tip-to-tip. The Apollo Lunar Sounder Experiment also uses a dipole antenna.

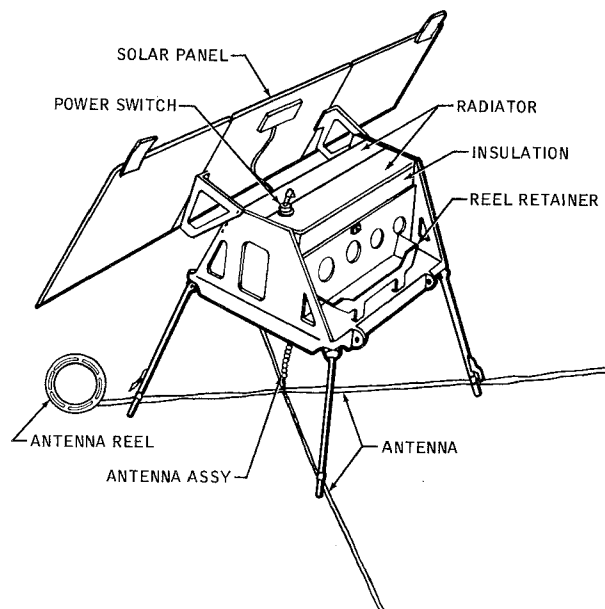

FIGURE 62.—SEP transmitter. The panel on top of the transmitter contains solar cells that convert the Sun's energy into electrical energy. The astronaut sets the transmitter on the surface of the Moon, roughly levels it, adjusts the solar cell panel to point directly towards the Sun, and extends the antennas. NASA PHOTO S-72-49042.

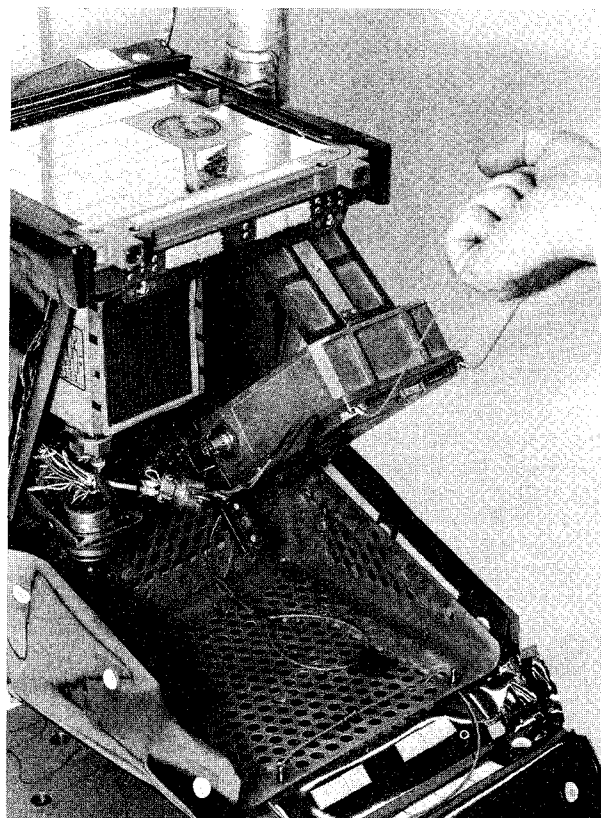

FIGURE 63B.—Removing the SEP tape recorder. After EVA 3, the cassette tape recorder is removed by the astronaut from the SEP receiver and stowed in the LM for return to Earth. The entire recorder is brought back because of the difficulty of removing the cassette. Shown also in this figure is the thermometer (on top of the box) that measures the internal temperature of the SEP receiver.

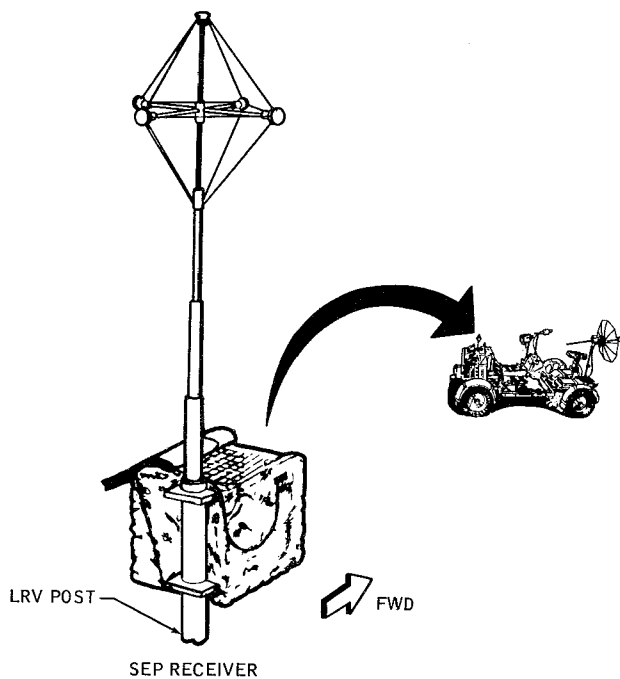

FIGURE 63A.—SEP receiver. The receiver is mounted on the rear of the Rover. Data, measured while the Rover moves along a traverse, are also recorded automatically on a cassette tape recorder. NASA PHOTO S-72-49033.

transmitter and its antenna are shown in figure 62. The receiver is shown in figure 63. The transmitter uses power directly from the Sun generated by solar cells in the large panel on top. The receiver uses internal batteries.

The basic principle of SEP, interferometry, is a familiar one in science, engineering, and technology. It is also familiar to you although you may not yet realize it. It involves only the interference of two or more waves to produce a "synthetic wave." For example, the pattern produced by the two sets of waves on the surface of a pond when two pebbles are dropped at the same time a few feet apart, is an interference pattern. The colors produced by a thin film of oil is also an interference phenomenon. And finally, "ghosts" on your TV screen are the result of interference. In figure 64, the geometry of SEP is shown. Energy

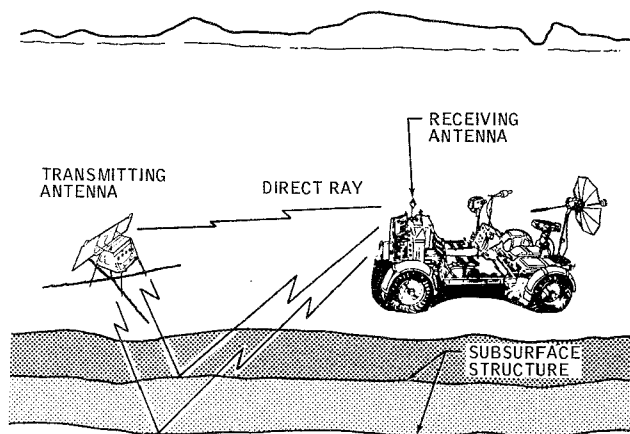

FIGURE 64.—Geometry of the SEP experiment. The transmitting antenna radiates energy in all directions. One part of the energy travels above the Moon's surface, labeled direct ray. Another part travels just below the surface (but omitted in the figure for simplicity). Still a third part is reflected from any subsurface structures in the Moon. All of these waves combine to produce interference patterns. This figure is schematic only and is not drawn to a uniform scale. NASA PHOTO S-72-49037.

in the form of radiowaves radiates from the transmitting antenna. Some of the energy travels *above* the Moon's surface directly to the receiver and some travels *below* the surface to the receiver. The combination of these two waves produces an interference pattern. By detecting and measuring this interference pattern, we can determine two things about the Moon: (1) the speed of radiowaves in the subsurface, and (2) the ease of propagation of radiowaves in the Moon. This second property, termed attenuation, is one of the characteristic properties of materials. In addition to these two waves, a third may also be present. Any subsurface layer will reflect energy back towards the surface and it too will produce an interference pattern. This additional interference makes the analysis of our data more complicated but adds greatly to the information about the Moon's interior.

Energy will be returned to the surface not only by rock layers but also by such reflecting surfaces as large boulders, breaks in the rocks (geologically speaking, faults), and any major changes in the electrical properties of the lunar soil and rocks. Thus a complete analysis of the data will reveal the presence of such features.

On the Moon, we will actually use two transmitting antennas because the characteristics of the

dipole antenna on the Moon are different when viewed *along* the antenna from those viewed *perpendicular* to the antenna. We also use radiowaves of several frequencies—1, 2.1, 4, 8.1, 16, and 32.1 Megahertz. Because the depth of penetration into the Moon depends upon the frequency of the radio signal, this set of frequencies will allow us to examine the lunar subsurface to several depths and with good resolution at each depth.

### Lunar Traverse Gravimeter Experiment (LTG)

Minute variations in the value of gravity on the surface of the Earth have led to major discoveries about the rocks hidden from sight beneath the surface. In Colonel Everest's geographical survey of India, about 100 years ago, the existence of "roots" beneath the Himalayas was discovered. The "roots" were really just a deficiency of mass beneath the mountains. That relation has since been shown to be true for many other mountains. Similarly ocean areas have "antiroots," that is high density rock lies at a shallower depth under the oceans than elsewhere. On a smaller scale, variations in the value of gravity have been used to look at rocks beneath the surface, often to find either oil or ore bodies. For example, in the early 1930's, oil was discovered around salt domes. Because salt domes are usually lighter than the surrounding rocks and hence cause a small decrease in the value of gravity immediately above the dome, the value of gravimeters in the search for oil became obvious. Gravimeters are instruments which can detect extremely small variations in the value of gravity. The effect of a salt dome, for instance, is often not larger than 2 or 3 millionths of the value of gravity. To detect this effect accurately, the precision of the gravimeter has to be better than a 10 millionths part of gravity!

Gravimeters have also been used to study valleys and the rocks beneath them in such areas as the southwestern United States. There, bedrock outcrops on the mountains but is buried in the valley beneath thick deposits of loose, highly porous materials termed alluvium. Because the density of the alluvium is less than the density of the bedrock, the gravity values are less over the valley than over the ranges. By measuring the gravity differences, the thickness of the alluvium in the valleys can be determined.

The objective of the LTG on the Moon is to solve

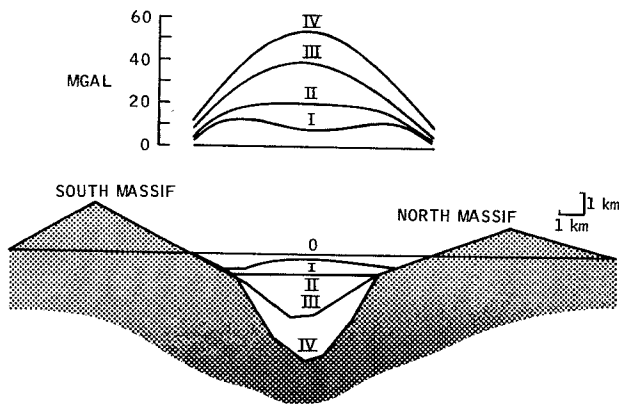

FIGURE 65.—Gravity at Taurus-Littrow. The shape of the bedrock surface beneath the valley strongly influences the values of gravity. Shown here are the *calculated* values of gravity that would be produced by various shapes. Comparison of the actual data obtained on the Moon with these curves will help us choose the correct shape. (Figure courtesy—M. Talwani.) NASA PHOTO 8-72-50290.

a problem somewhat similar to the “valley gravity” problem. In the Taurus-Littrow area, two mountains of highland material lie on either side of the valley (figure 6). The valley floor is covered everywhere with the thin regolith and with the DARK MANTLE material which may be thin. There are also thin superficial deposits of the LIGHT MANTLE material. But the principal formation in the valley is the so-called SUBFLOOR UNIT whose thickness is unknown. In figure 65, a profile across the valley, four possible thicknesses of the SUBFLOOR UNIT are indicated by the curves labelled I, II, III, and IV. The corresponding gravity variation is plotted on top (one mgal is roughly equal to 1 millionth of the value of gravity on Earth). From these curves we see that the gravity effect is minimal if the MASSIF material is buried beneath a thin SUBFLOOR UNIT. However, if the SUBFLOOR UNIT is several kilometers thick, the gravity effect will be large.

In a general way, large variations in the value of gravity at Taurus-Littrow will suggest “lumpiness” in the shallow part of the lunar crust, whereas small variations of gravity will favor ideas of uniform horizontal layering to great depth.

The LTG equipment uses a principle that is quite old but uses it in a way that is rather new. The frequency of vibration of a mass suspended freely on a spring depends upon the value of gravity as well as several other parameters. If the

values of these other parameters are known, then the frequency of vibration can be used to determine the value of gravity. In the lunar equipment, the frequency of the vibration of the spring is measured electronically, an easy measurement to make with extremely high precision. Any variations in the value of gravity will be seen as variations in the frequency of vibration. (Actually, the mass is suspended *between* two springs, as shown in figure 66, but the analysis here is still essentially correct.) The unit is quite similar to those used in the guidance systems of missiles and is termed a vibrating string accelerometer, or VSA.

The LTG will be mounted on the rear of the Rover. At each stop, the astronauts will read the instrument and report the readings over the voice communications link to Mission Control. Those readings are *not* the values of gravity but must be converted through calibration tables. The external appearance of the equipment is shown in figure 67.

### Lunar Neutron Probe Experiment (LNP)

#### The Lunar Neutron Probe Experiment (LNP)

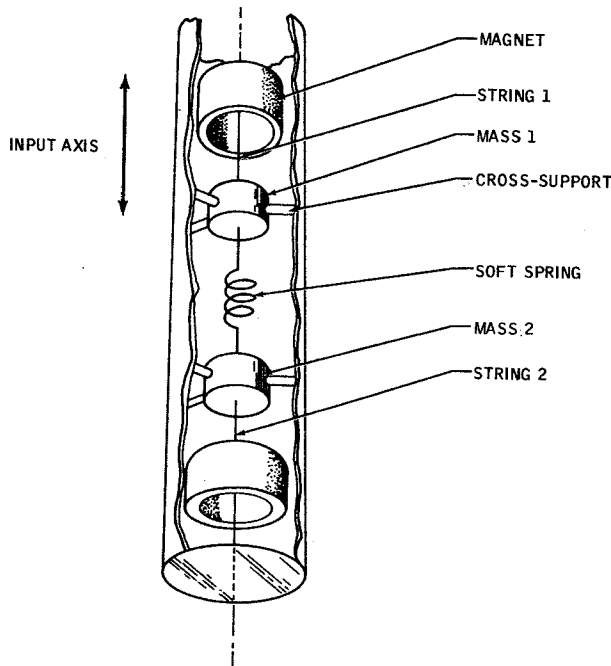

FIGURE 67.—Lunar Traverse Gravimeter. With this unit, the astronaut will measure the variation of gravity at several different spots on the Moon. The instrument will normally be mounted on the rear of the Rover. The inset shows the control buttons and the digital meter. NASA PHOTO 8-72-49035.

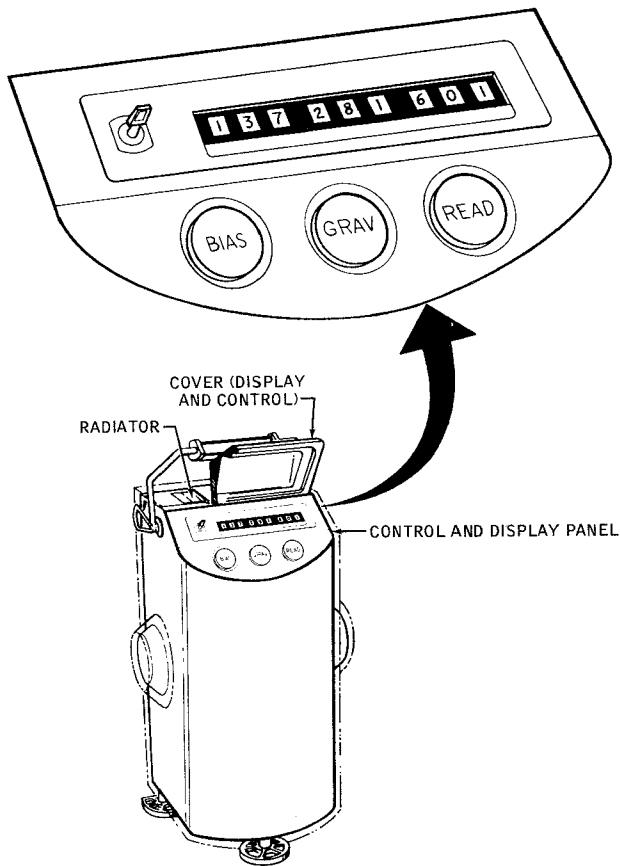

FIGURE 66.—Elements of the Lunar Traverse Gravimeter. Shown here is a schematic section of the vibrating string accelerometer, the sensor in the Traverse Gravimeter. The frequencies of vibration of the two strings depend on the value of gravity. From minute variations in the frequencies, measured electronically, we can measure minute changes in the value of gravity.

is an outgrowth of some rather sophisticated studies of the first samples returned from the Moon on Apollo 11. Those early studies showed clearly that nuclear reactions on the Moon involved neutron\* capture on certain isotopes of the elements gado-

\*Neutrons, protons, and electrons are the "building blocks" of atoms. The proton has a large mass and a positive electrical charge. The electron has a small mass, about .05 percent that of the proton, and a negative electrical charge. Neutrons have a mass rather close to the mass of a proton but unlike the proton, the neutron has no electrical charge. Atomic nuclei contain neutrons and protons but electrons occur only outside the nucleus. Neutrons outside the nucleus are unstable and change into other particles. Neutrons do not interact with electrons that surround the atomic nucleus but do interact with the nucleus itself.

linium and samarium, as well as other nuclei. The way in which these materials are distributed with depth in the Moon can be measured on cores obtained with drive tubes as well as the deep drill. Such data are extremely important to lunar science because they help us understand the physical processes that have produced lunar soil and that contribute to the continued mixing (or gardening, as some prefer to call it). With some plausible assumptions, even the time since a particular sample had been on the surface of the Moon can be estimated rather precisely. The primary purpose of the neutron flux experiment is to obtain data on the Moon that are needed for such estimations. Specifically, the LNP experiment will obtain data on the rates of neutron capture and measure their variations with depth beneath the lunar surface. The experiment will also provide some information on the energies carried by lunar neutrons.

The technique by which the LNP data are to be gathered is rather interesting. Neutrons inter-

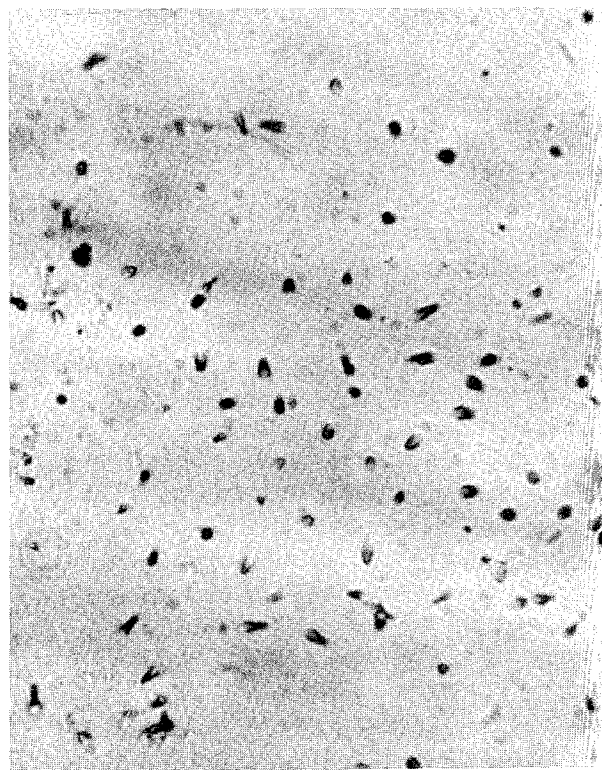

FIGURE 68.—Particle tracks. In the Lunar Neutron Probe neutrons interact with boron nuclei to produce alpha particles. The alphas then interact with a plastic to yield tracks like those seen in this photograph. (PHOTO COURTESY—D. BURNETT.)

## Cosmic Ray Detector Experiment (CRD)

Cosmic rays are just particles that have extremely larger energies and very high velocities. Their velocity is almost, but not quite, the speed of light. They are mostly protons and alpha particles (see section "Lunar Neutron Probe" for discussion). But 1 to 2 percent of the cosmic rays consist of the nuclei (that is, atoms with one or more electrons removed) of heavier elements. The cosmic rays seem to arrive from all directions and, although their origin is not yet known with certainty, they come from outside our solar system.

In addition to cosmic rays, the CRD equipment will detect low energy solar wind particles. The Sun has streaming out from it continuously a very thin gas that is composed of electrons, protons, hydrogen, helium, neon, certain other gases and other nuclear particles. (These are the elements we can measure directly; presumably all other elements are present too.) This very thin gas from the Sun is called the solar wind. The CRD experiment records the solar wind particles as well as cosmic rays.

The CRD experiment was flown on Apollo 16 but a solar flare occurred on April 17 and produced many particles. The tracks caused by the solar flare particles are both larger and more numerous than the tracks produced by the normal solar wind particles and cosmic rays, making the reading of the "normal record" very uncertain. So, the CRD experiment will be flown again on Apollo 17 in order to do those things that had been expected for the Apollo 16 flight. Of course, the Apollo 16 flare data are also very important because they carry information about the composition of the interior of the Sun. They are currently being studied.

In the CRD experiment, we obtain actual records of the particles. Plates of several special materials (some resemble plexiglass), shown in figure 70, are carried on the outside of the LM to the Moon and then brought back to Earth. The passage of particles through the material is recorded in the form of tiny tracks. The characteristics of these tracks seen through a microscope, tell us the kind of particle and, of course, its direction of travel. Some of the great interest in this experiment is due to the possibility that new elements may be discovered!

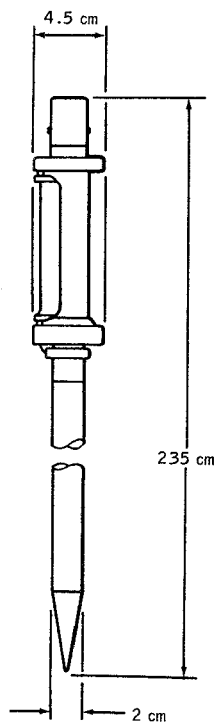

FIGURE 69.—Lunar neutron probe. The LNP is carried to the Moon in two sections and then assembled before being placed in the deep drill hole.

act readily with boron\* and produce alpha particles. The alpha particles, in turn, react readily with a particular plastic to produce microscopic tracks. The appearance of the tracks is shown in figure 68.

The appearance of the probe is shown in figure 69. The equipment consists of a probe in which the boron and plastic are separated until the astronauts reach the Moon. After the deep drill hole has been completed, and the core removed, the LNP will be placed in the hole. It will be placed in the hole during EVA 1 and then removed late in EVA 3, remaining in the hole for more than 40 hours. Before placing the probe in the hole, the boron is rotated so that it is adjacent to the plastic. Thus when neutrons interact with the boron, alpha particles are produced and, in turn, produce tracks in the plastic. After the probe is removed from the hole, the boron is again separated from the plastic for the journey back home. After the return of Apollo 17, the plastic will be examined microscopically in the laboratory and the number of tracks counted as a function of depth.

\*Boron is one of the elements. It is obtained from deposits in California's Mojave Desert. Two of its compounds, boric acid and borax, are household items. A third, boron nitride, is as hard as diamond (which had been thought to be the hardest substance of all).

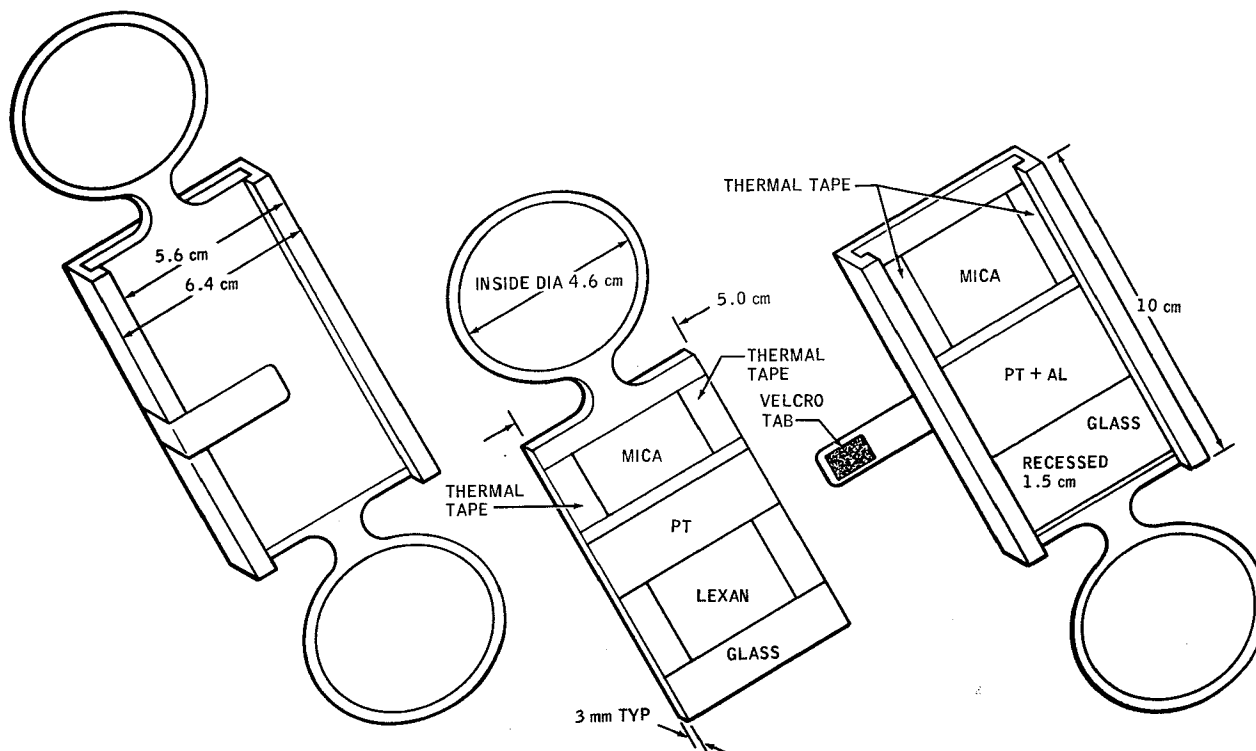

FIGURE 70.—Cosmic ray detector experiment. Small pieces of mica, aluminum, and other materials are exposed to particles in space. The passage of energetic particles through these materials, produces damage along their path. After return of the ORD, to Earth, the tracks are chemically etched so they can be seen with a microscope. The three separate pieces shown in the sketch slide together for transport to the Moon and for return to Earth.