

Appendix D-ET Historic Photos



Figure D-1. Liquid hydrogen tank of the ET is installed into the S-1C Test Stand at MSFC for a structural test, March 1, 1978.

Source: NASA – MSFC, ID: MSFC-7887775, accessed at <http://www.nix.ksc.nasa.gov>.



Figure D-2. Liquid oxygen tank of the ET during a hydroelastic modal test at MSFC,
May 1, 1978.

Source: NASA, Marshall Space Flight Center, MSFC-7889312, accessed at
<http://www.nix.ksc.nasa.gov>.

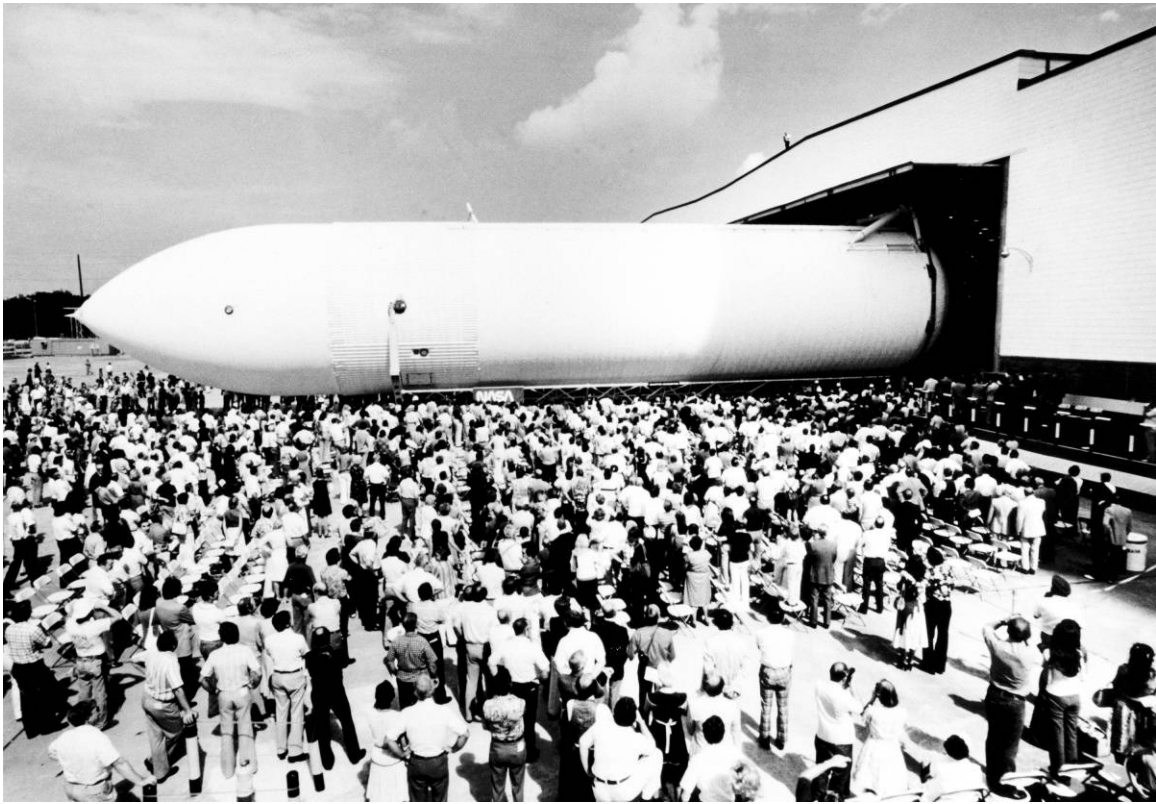

Figure D-3. Rollout of the first external tank, the MPTA, September 9, 1977.
Source: NASA, Marshall Space Flight Center, MSFC-7889312, accessed at
<http://www.nix.ksc.nasa.gov>.



Figure D-4. Installation of ET into the Dynamic Test Stand (Building 4550) at MSFC for Mated Vertical Ground Vibration Test, September 29, 1978.

Source: NASA, Marshall Space Flight Center, MSFC-7992267, accessed at <http://www.nix.ksc.nasa.gov>.



Figure D-5. A Standard Weight Tank (foreground) and a Lightweight Tank (rear) in final assembly at MAF, date unknown.

Source: NASA, Johnson Space Center, Imagery Online, jsc2010e009753.

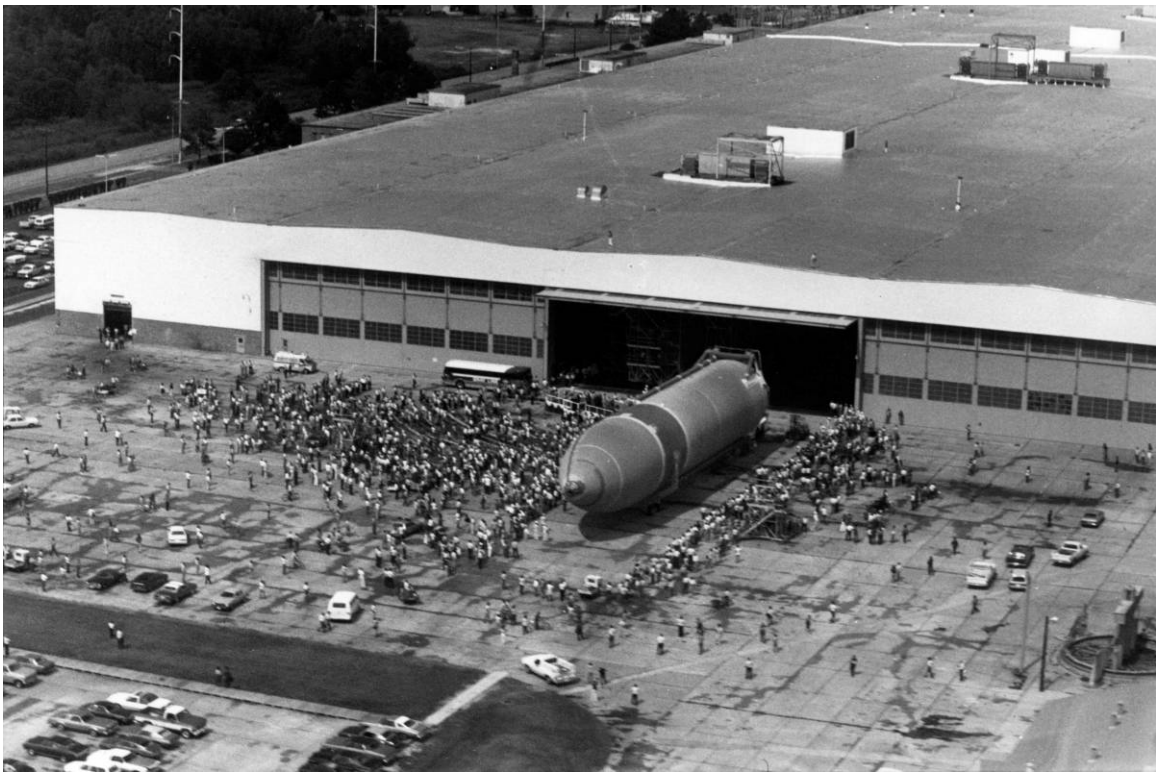

Figure D-6. First Lightweight Tank (ET-8) rolls out, September 10, 1982.
Source: NASA, Johnson Space Center, Imagery Online, jsc2010e009759.

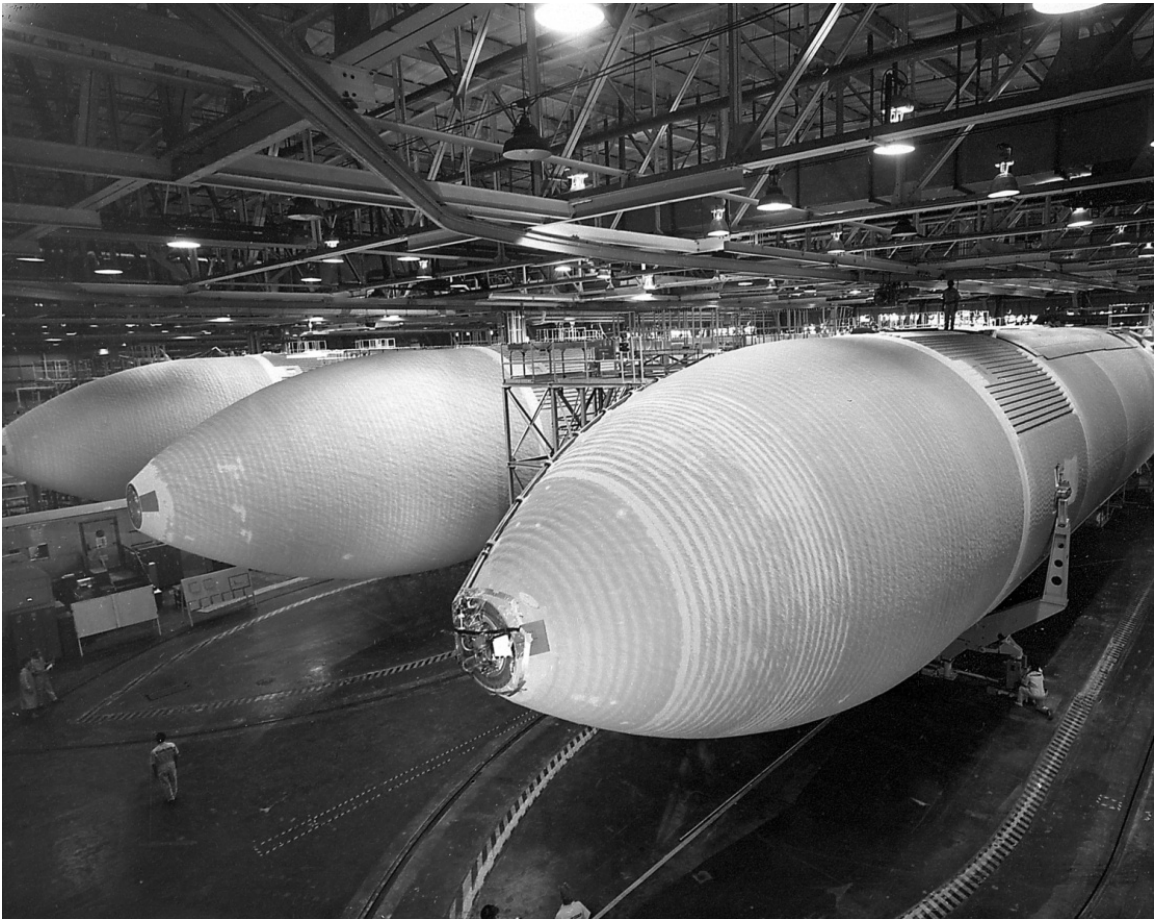

Figure D-7. Lightweight Tanks (LWT) at MAF, July 1, 1983.
Source: NASA, Marshall Space Flight Center, MSFC-8336102, accessed at
<http://www.nix.ksc.nasa.gov>.



Figure D-8. First Super Lightweight Tank (ET-96) rolls out, January 16, 1998.
Source: NASA, Johnson Space Center, Imagery Online, jsc2010e009775.



ET-138 begins its rollout to the Michoud harbor.

Figure D-9. The last of 136 tanks (ET-138) is rolled out at Michoud, July 8, 2010.
Source: NASA, Marshall Space Flight Center, *Marshall Star*, July 15, 2010, 1.

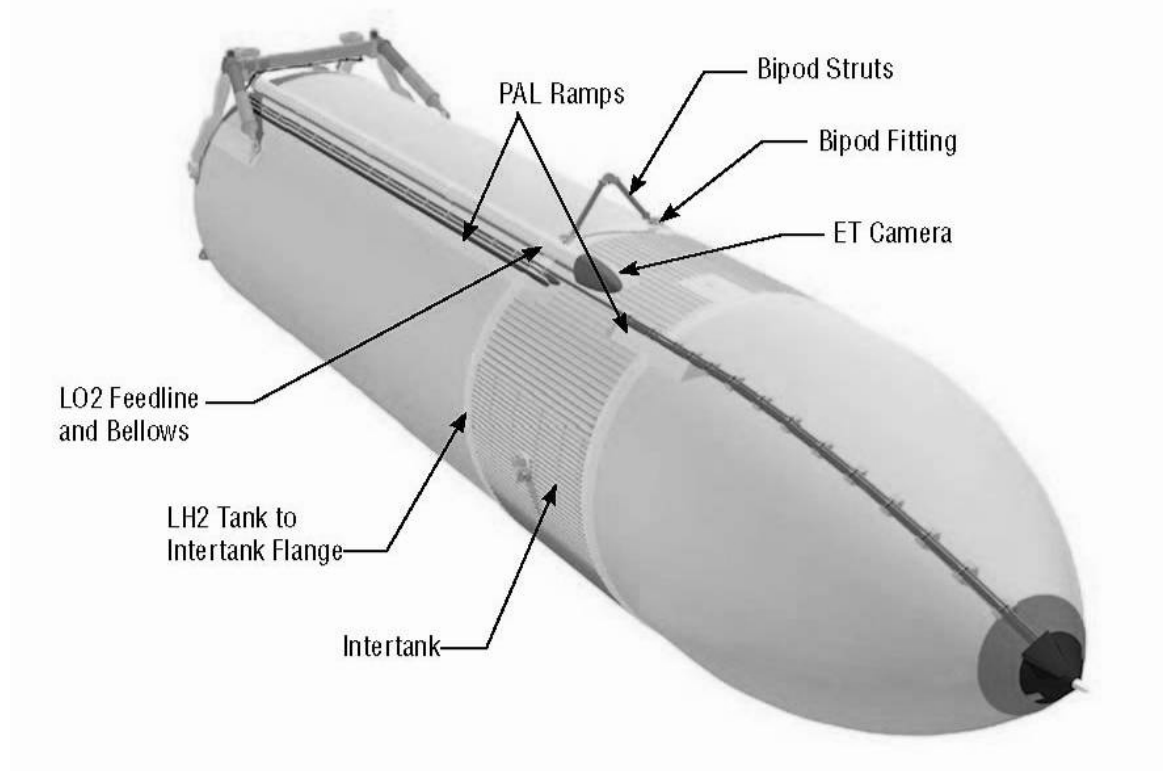

Figure D-10. Diagram showing improvements to the ET following the *Columbia* accident.
Source: NASA, Marshall Space Flight Center, *NASA Facts: Improvements to the Space Shuttle's External Tank*, 1; accessed at http://www.nasa.gov/centers/marshall/pdf/119016main_Shuttle_ET_FS.pdf.



Figure D-11. PAL Ramp, August 12, 2004.

Source: NASA, Marshall Space Flight Center/Lockheed Martin, accessed at http://www.nasa.gov/centers/marshall/images/content/104631main_99600main_PAL_Ramp_8-12-04_3000x2000.jpg.



Figure D-12. Lockheed Martin technicians installing ice/frost ramps.
Source: NASA, *NASA Facts: Space Shuttle External Tank ET-128, STS-124*, 2; accessed at http://www.nasa.gov/centers/marshall/pdf/228641main_8-368946_%282%29.pdf.

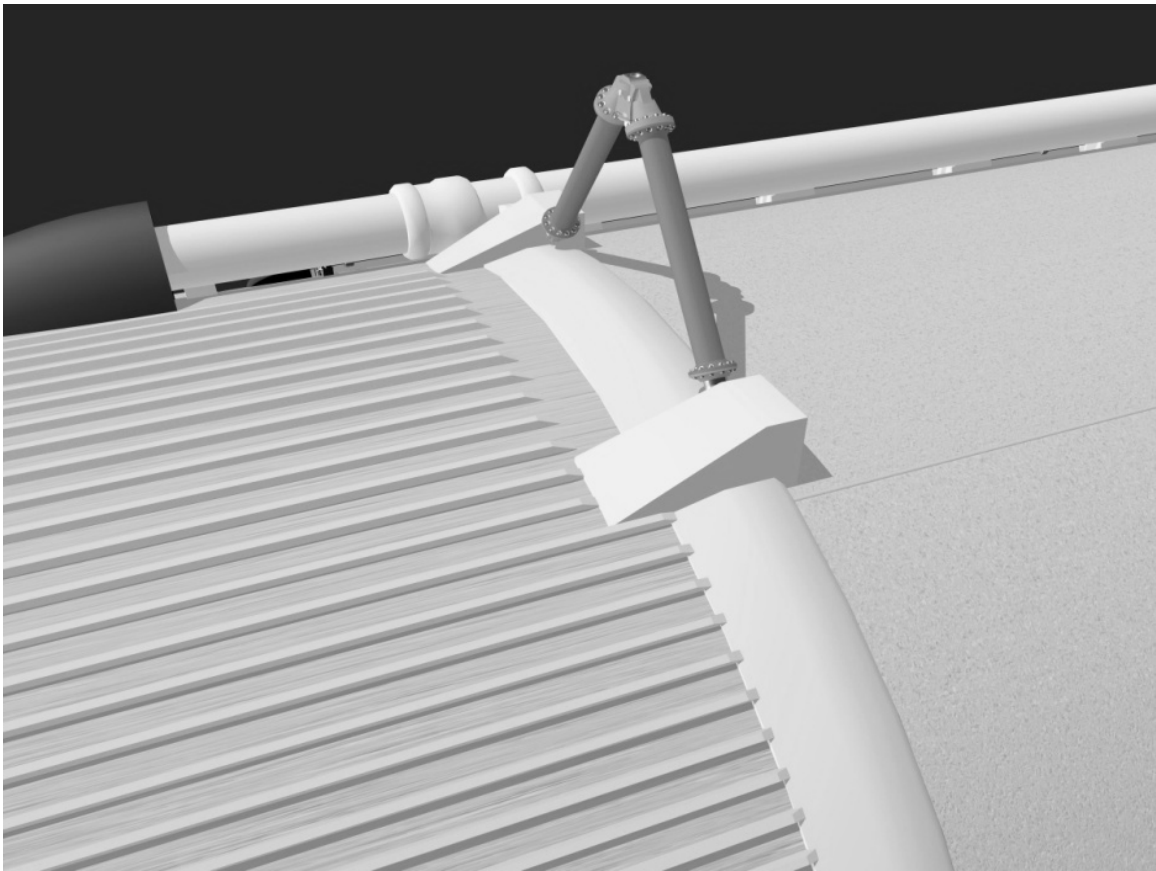

Figure D-13. Forward bipod fitting, pre-*Columbia* accident.
Source: NASA, Marshall Space Flight Center/Lockheed Martin, accessed at
http://www.nasa.gov/centers/marshall/images/content/104648main_99505main_Bipod_Pre-Columbia_2400x1800.jpg

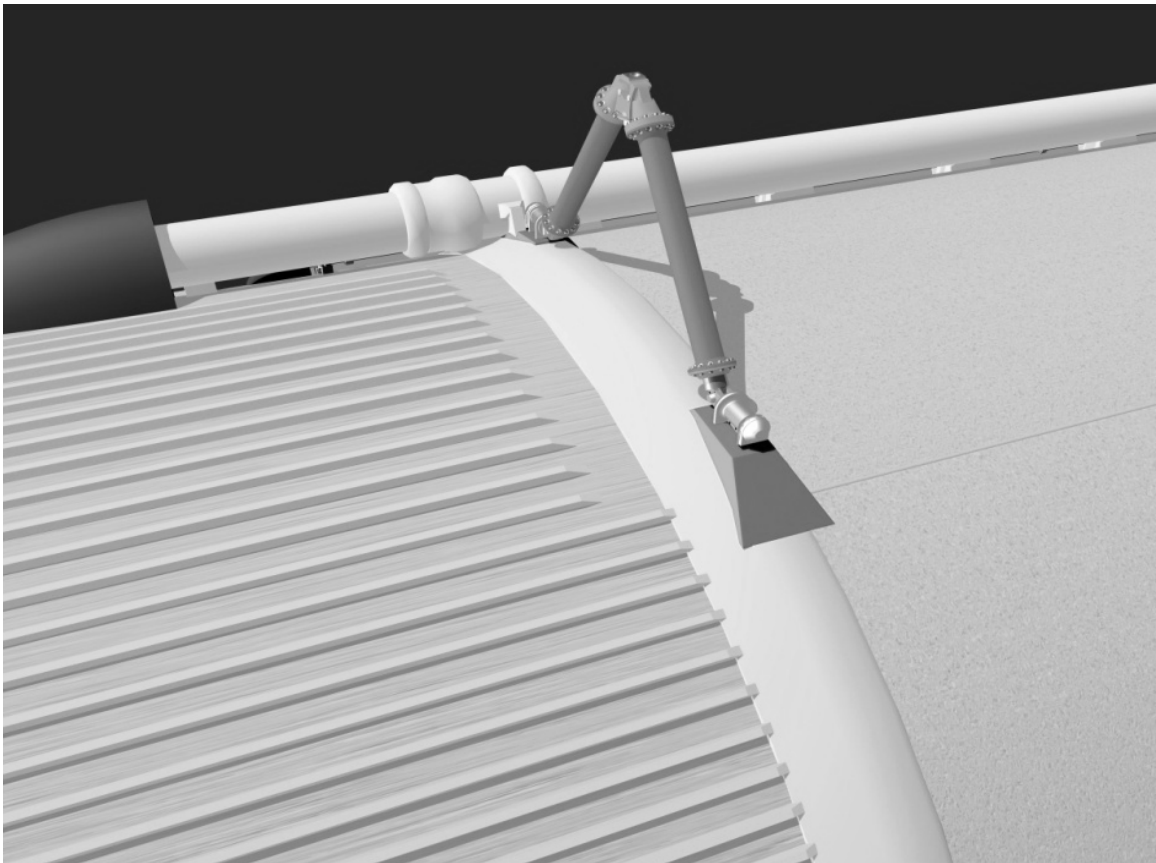

Figure D-14. Forward bipod redesign.

Source: NASA Marshall Space Flight Center/Lockheed Martin, accessed at http://www.nasa.gov/centers/marshall/images/content/104701main_99508main_Bipod_Redesign_2400x1800.jpg.

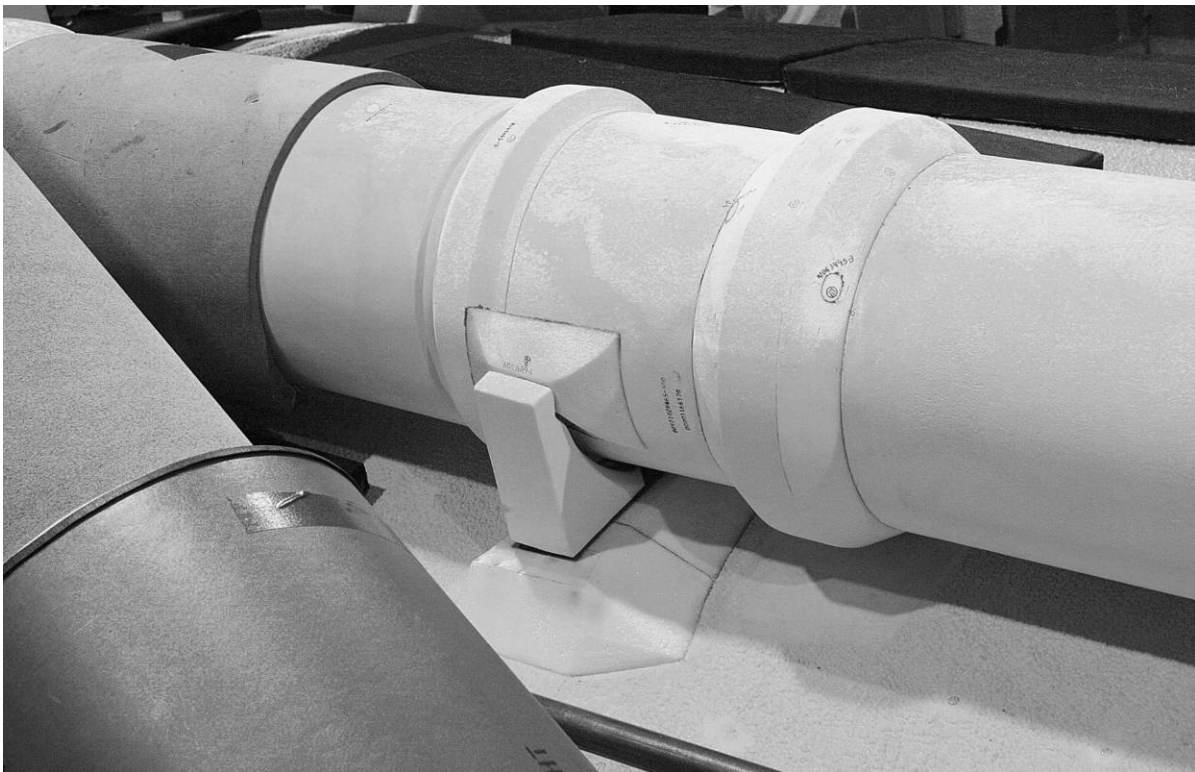
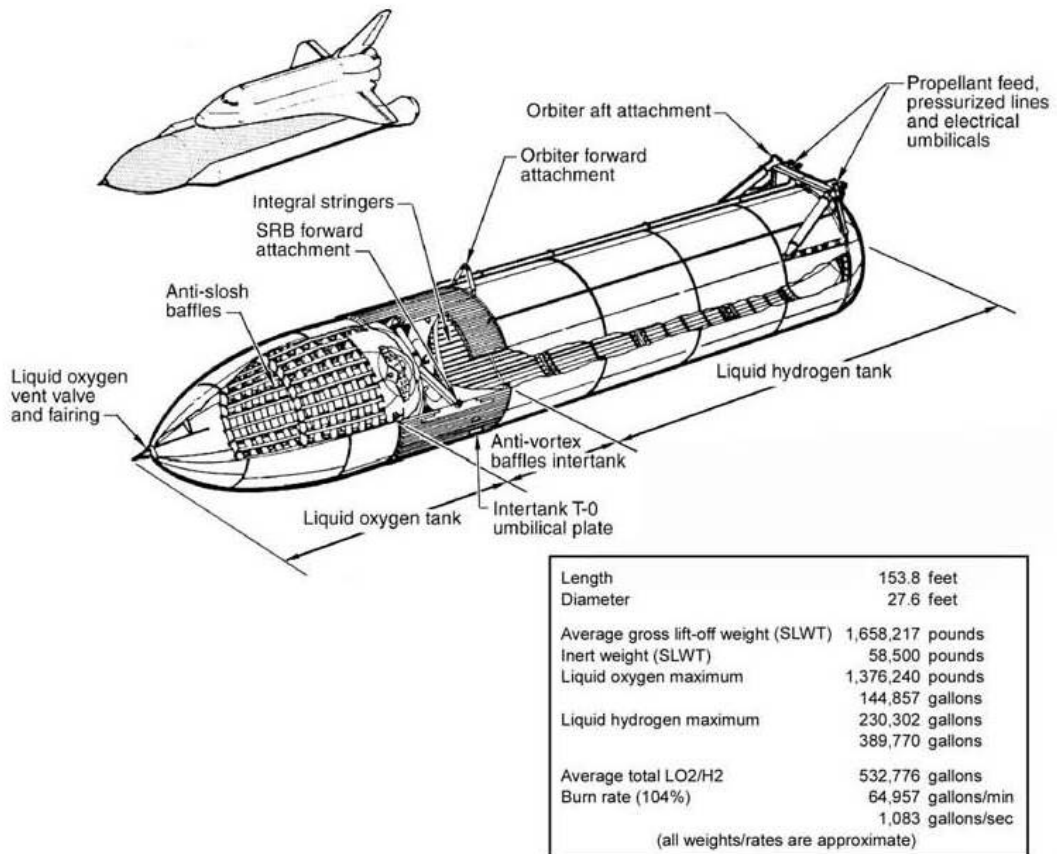

Figure D-15. Redesigned liquid oxygen feedline bellows, August 12, 2004.
Source: NASA, Marshall Space Flight Center/Lockheed Martin, accessed at
http://www.nasa.gov/centers/marshall/images/content/104640main_99417main_Bellows_8-12-04_2400x1541.jpg.



Figure D-16. A technician working on an ECO connector.

Source: NASA, *NASA Facts: Engine Cutoff Sensor System, 2*; accessed at http://www.nasa.gov/pdf/210230main_ECO_Sensor_System_Fact_Sheet.pdf.



usa007587_034r1.tif

Figure D-17. Diagram of the Super Lightweight Tank.
 Source: USA, *Shuttle Crew Operation Manual*, 1.3-1.

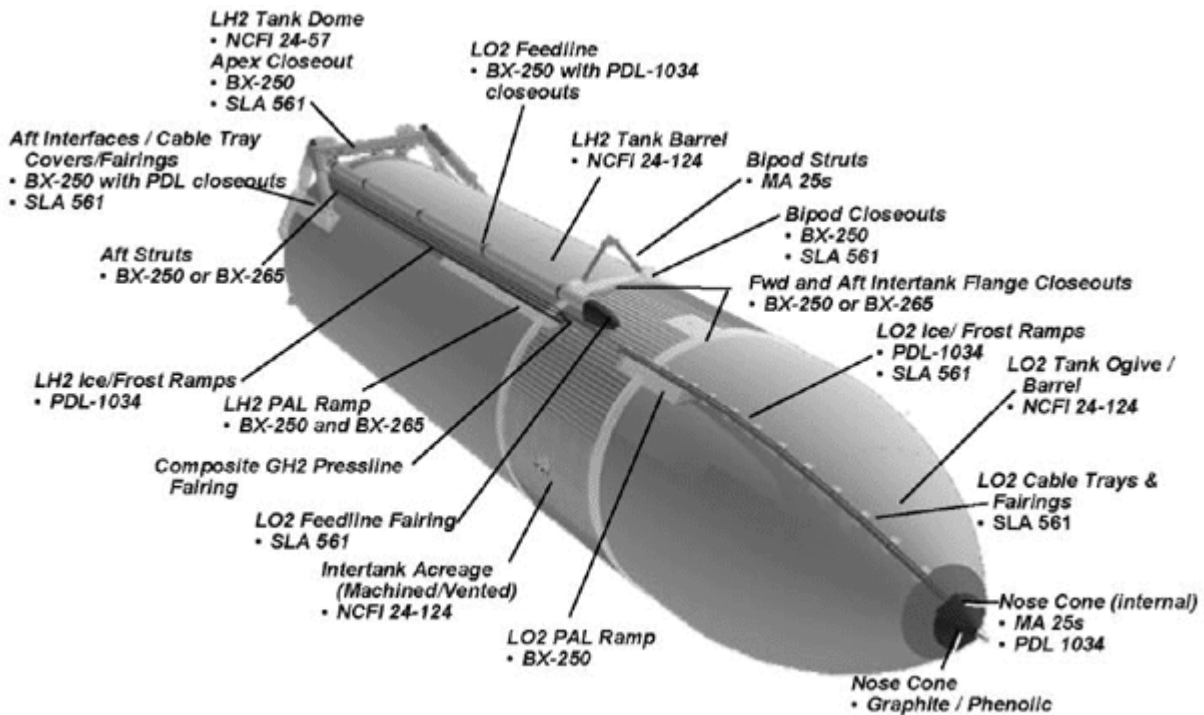

Figure D-18. Diagram of the External Tank.
 Source: NASA, Marshall Space Flight Center, accessed at
http://maf.msfc.nasa.gov/et_overview.html

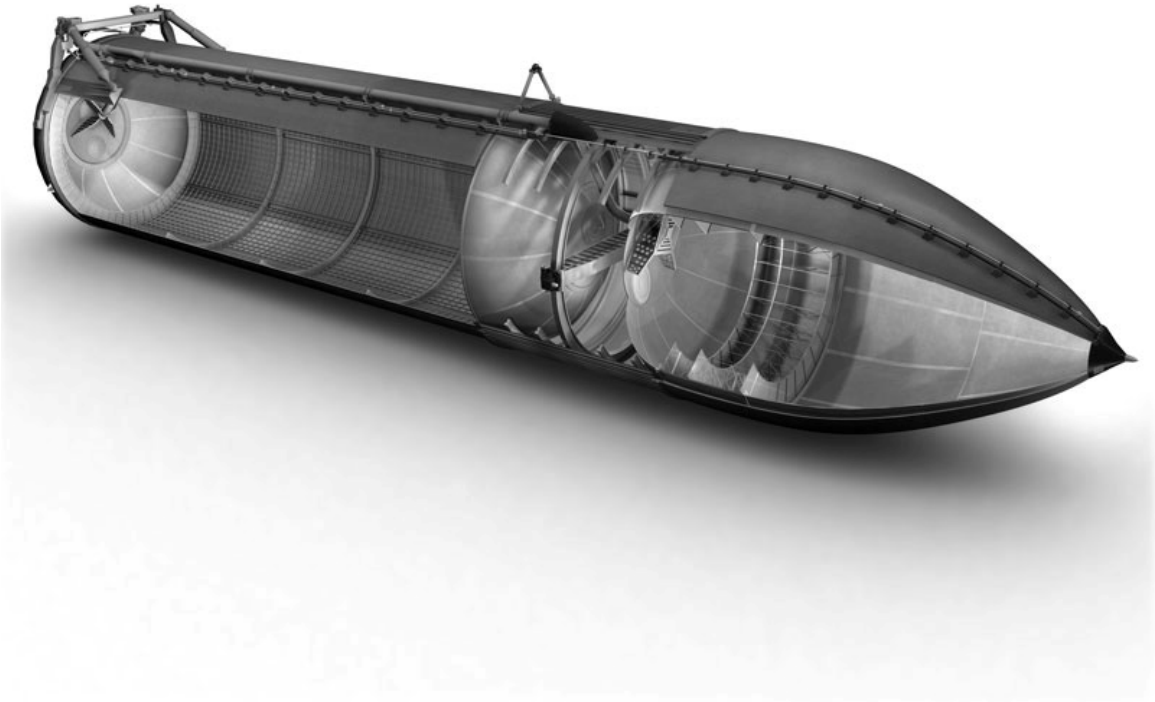

Figure D-19. Cutaway view of the External Tank.
Source: NASA, Johnson Space Center, Imagery Online, jsc2010e009729.

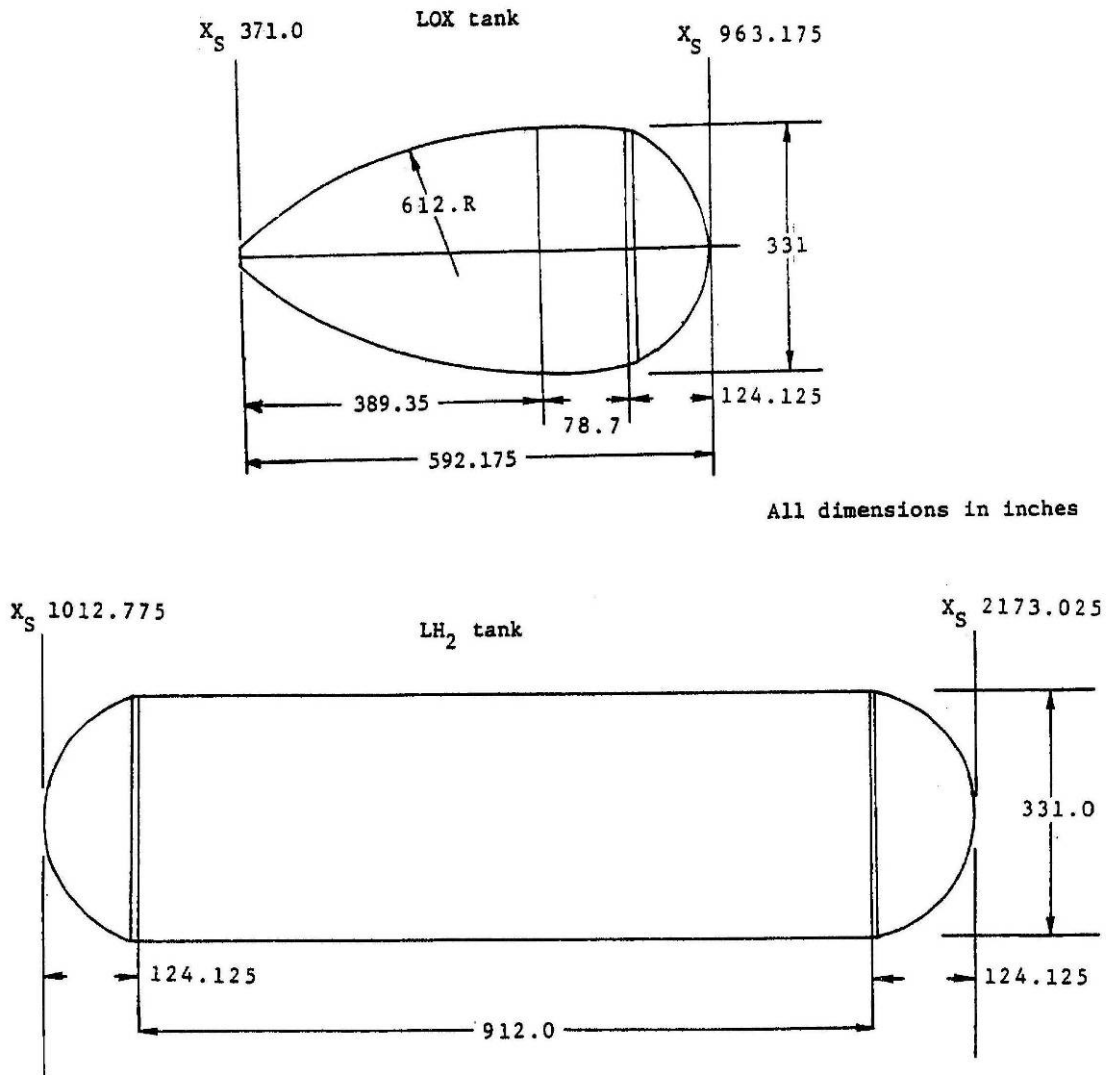

Figure D-20. General dimensions of the ET LO₂ (LOX) and LH₂ tanks.
Source: NASA, *Shuttle Operational Data Book*, Volume 1, Figure 4.4-2.

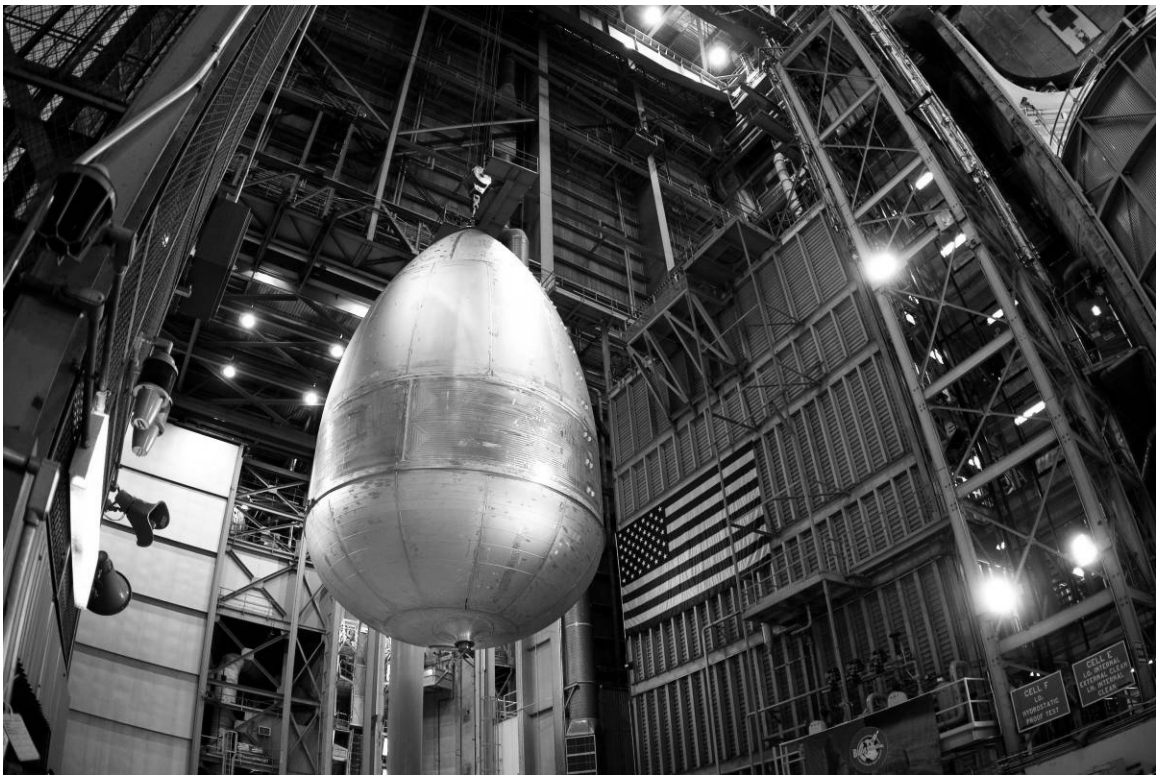

Figure D-21. The liquid oxygen tank for ET-138 at MAF, May 19, 2009.
Source: NASA, Johnson Space Center, Imagery Online, jsc2010e009667.

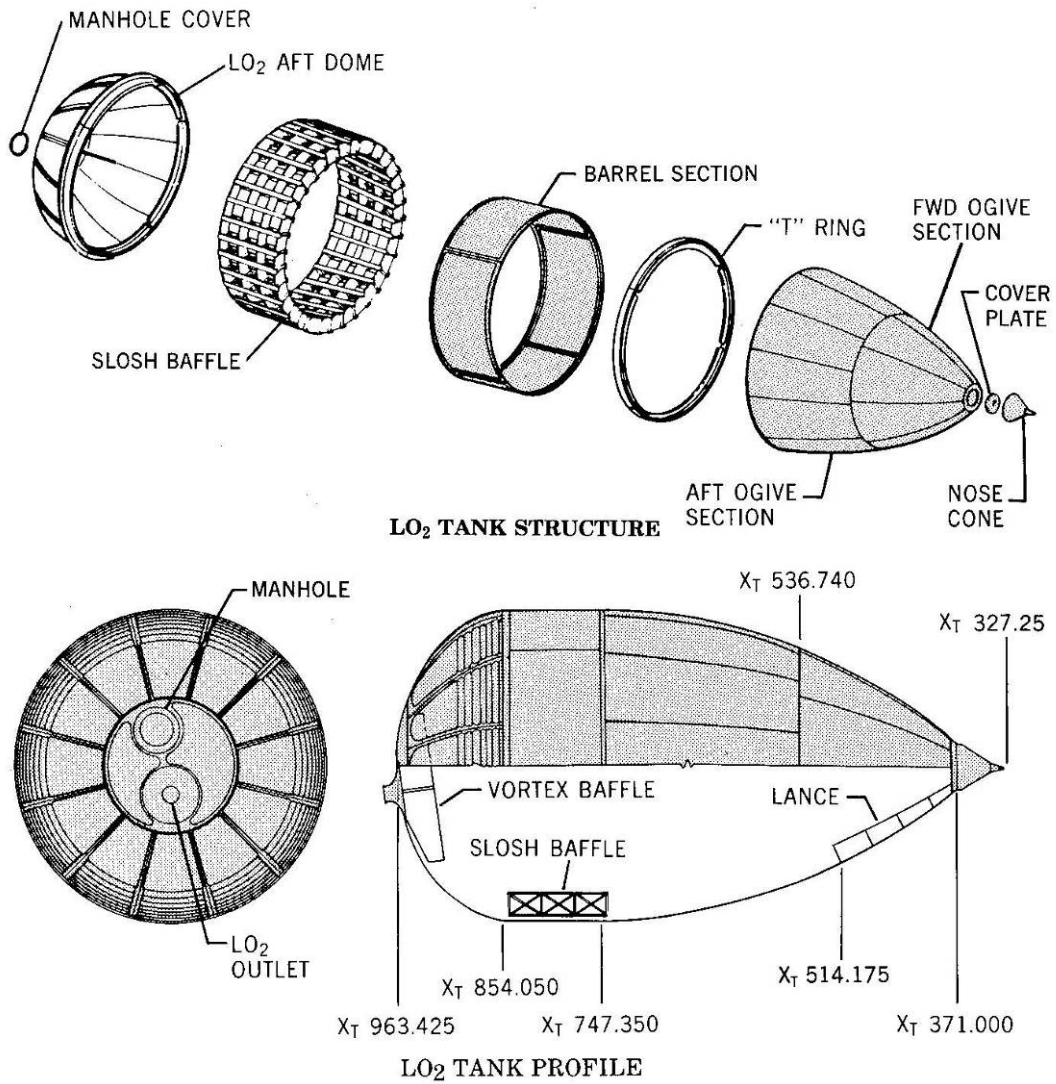

Figure D-22. Diagram of the liquid oxygen tank.
 Source: Martin Marietta, *Space Shuttle External Tank. System Definition Handbook*,
 Volume I, VI-2.



Figure D-23. View of the intertank for ET-138.
Source: NASA, Johnson Space Center, Imagery Online, jsc2010e009713.

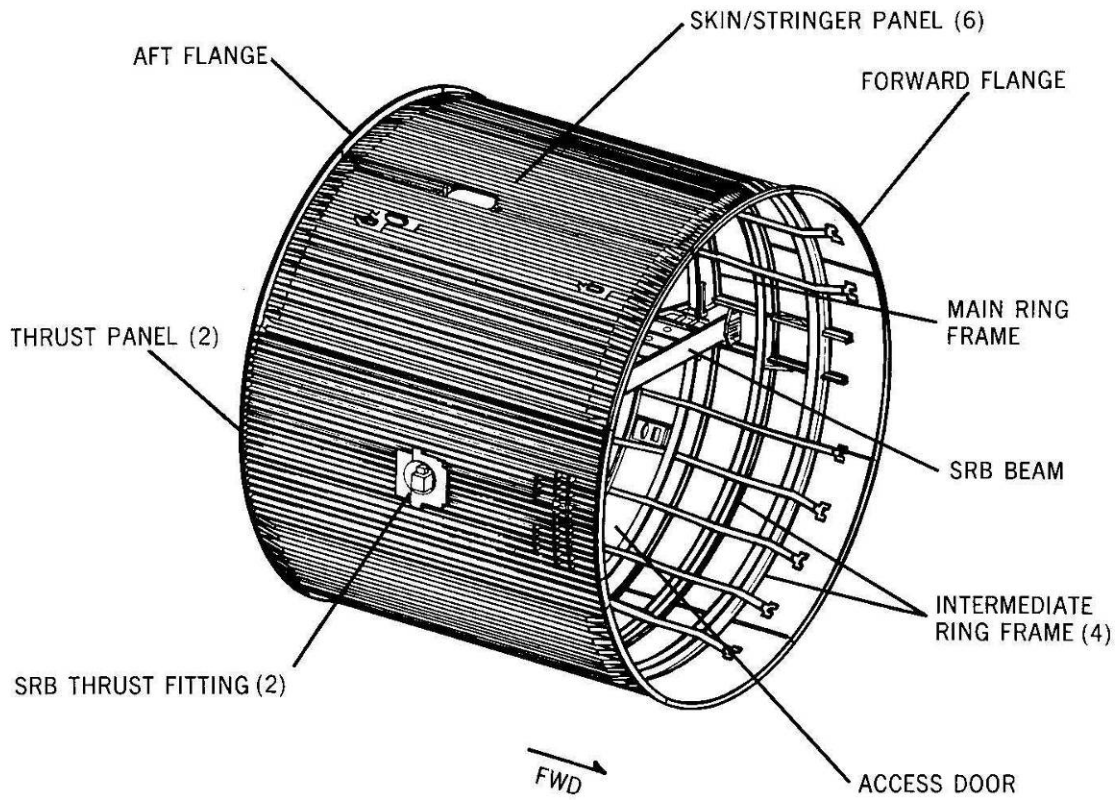

Figure D-24. Diagram of the intertank.
Source: Martin Marietta, *Space Shuttle External Tank. System Definition Handbook*,
Volume I, VII-2.



Figure D-25. The liquid hydrogen tank for ET-138 at MAF, May 30, 2009.
Source: NASA, Johnson Space Center, Imagery Online, jsc2010e009748.



Figure D-26. The interior of a liquid hydrogen tank during assembly at MAF, August 28, 2008.
Source: NASA, Johnson Space Center, Imagery Online, jsc2010e009742.

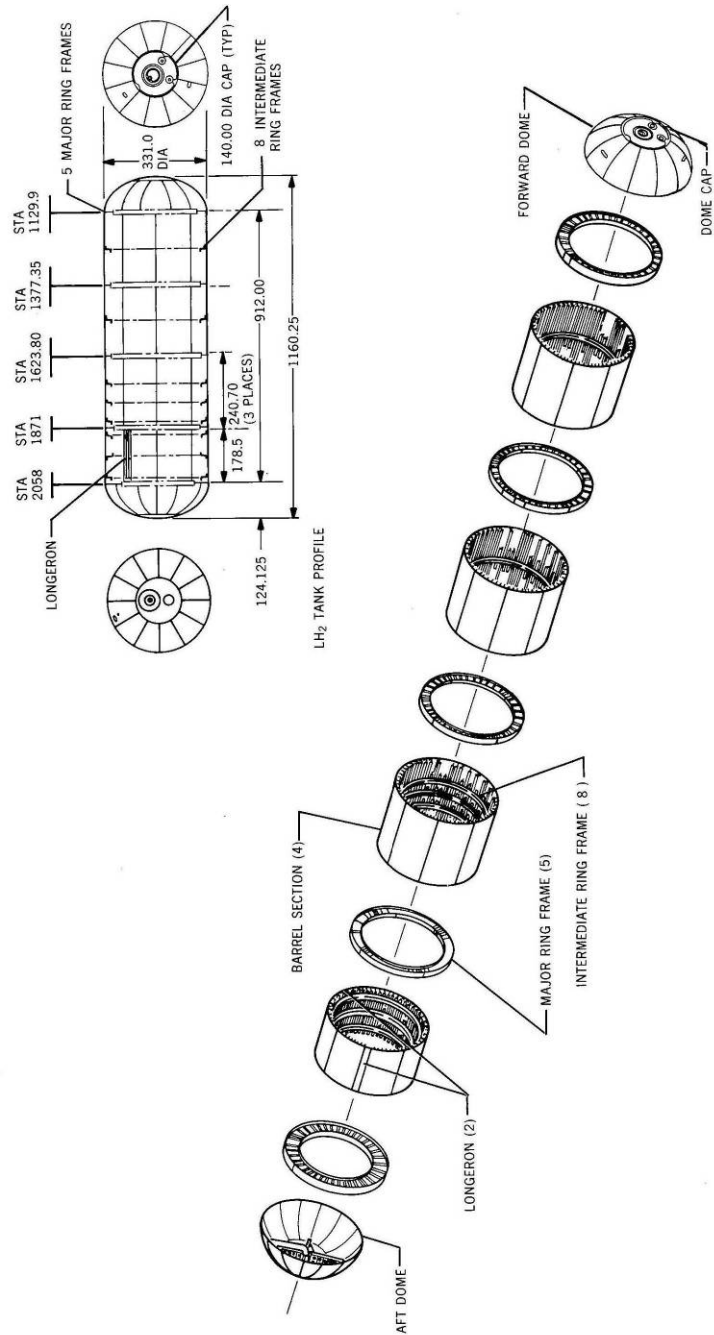

Figure D-27. Diagram of the liquid hydrogen tank.
 Source: Martin Marietta, *Space Shuttle External Tank. System Definition Handbook*,
 Volume I, VIII-3/VIII-4.

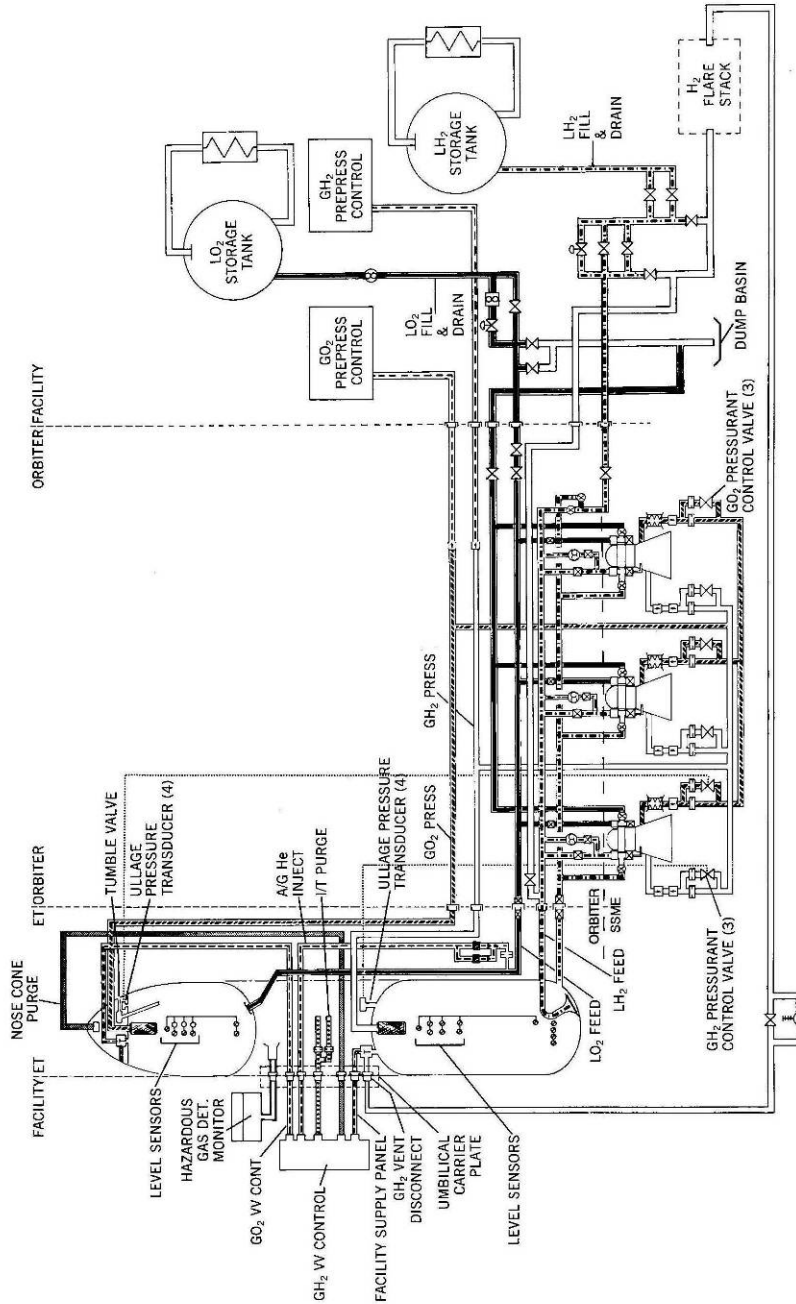

Figure D-28. Schematic of the main propulsion system.
 Source: Martin Marietta, *Space Shuttle External Tank. System Definition Handbook*,
 Volume I, IX-7/IX-8.

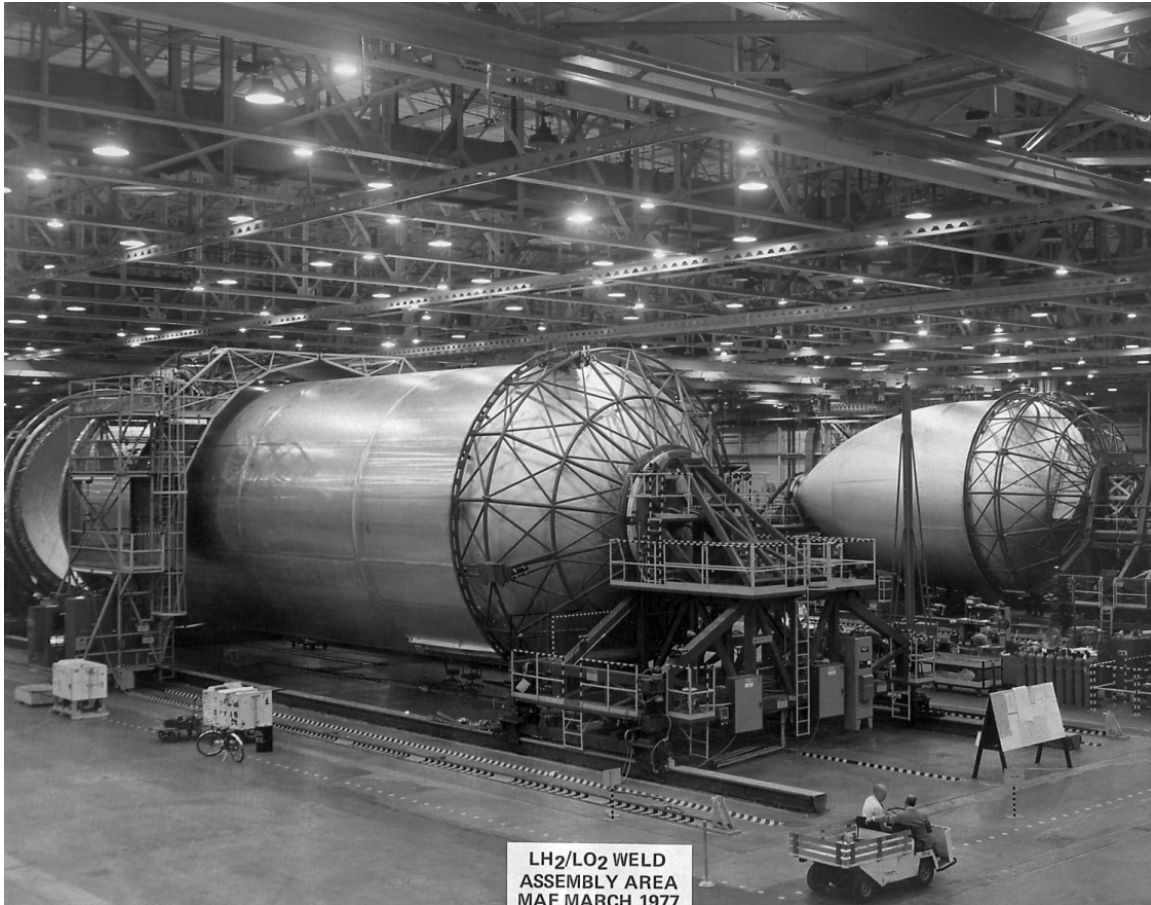

Figure D-29. Liquid hydrogen tank and liquid oxygen tank for the ET being assembled in the weld assembly area of MAF, March 1, 1977.

Source: NASA, Marshall Space Flight Center, MSFC-7777894, accessed at <http://www.nix.ksc.nasa.gov>



Figure D-30. The LO2 tank for ET-138 leaves proof testing cell at MAF, May 31, 2009.
Source: NASA, Johnson Space Center, Imagery Online, jsc2010e009664.

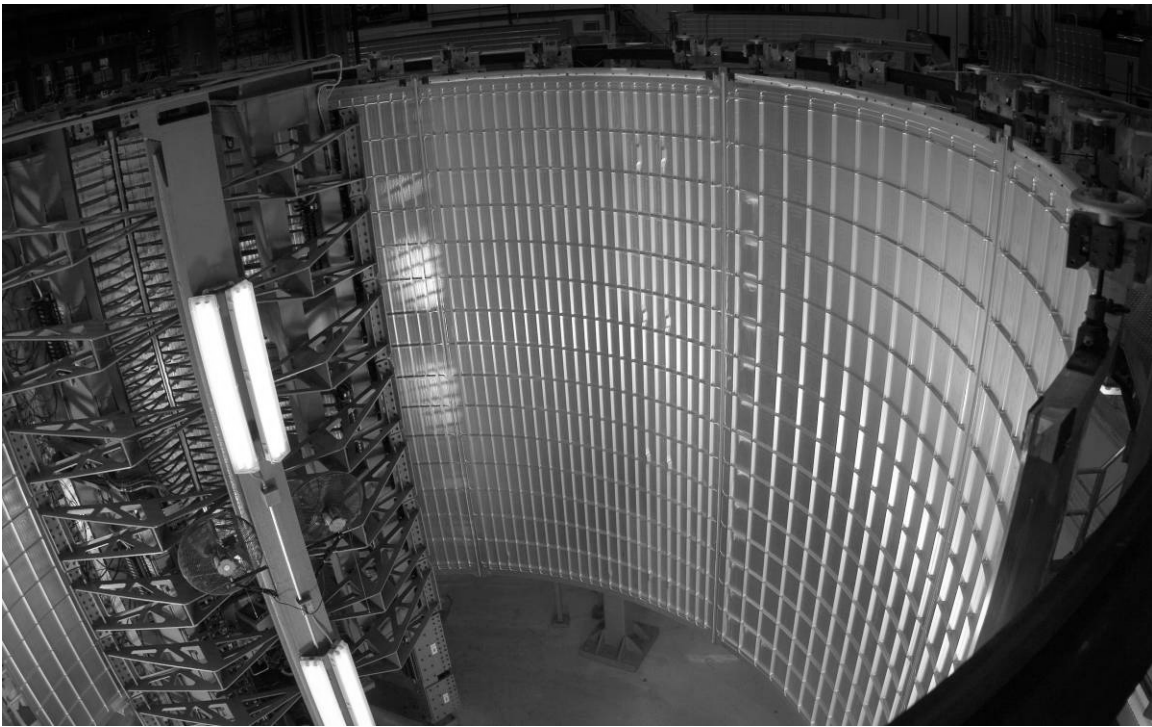

Figure D-31. Friction stir welding of LH2 barrel panels at MAF, August 28, 2008.
Source: NASA, Johnson Space Center, Imagery Online, jsc2010e009645.

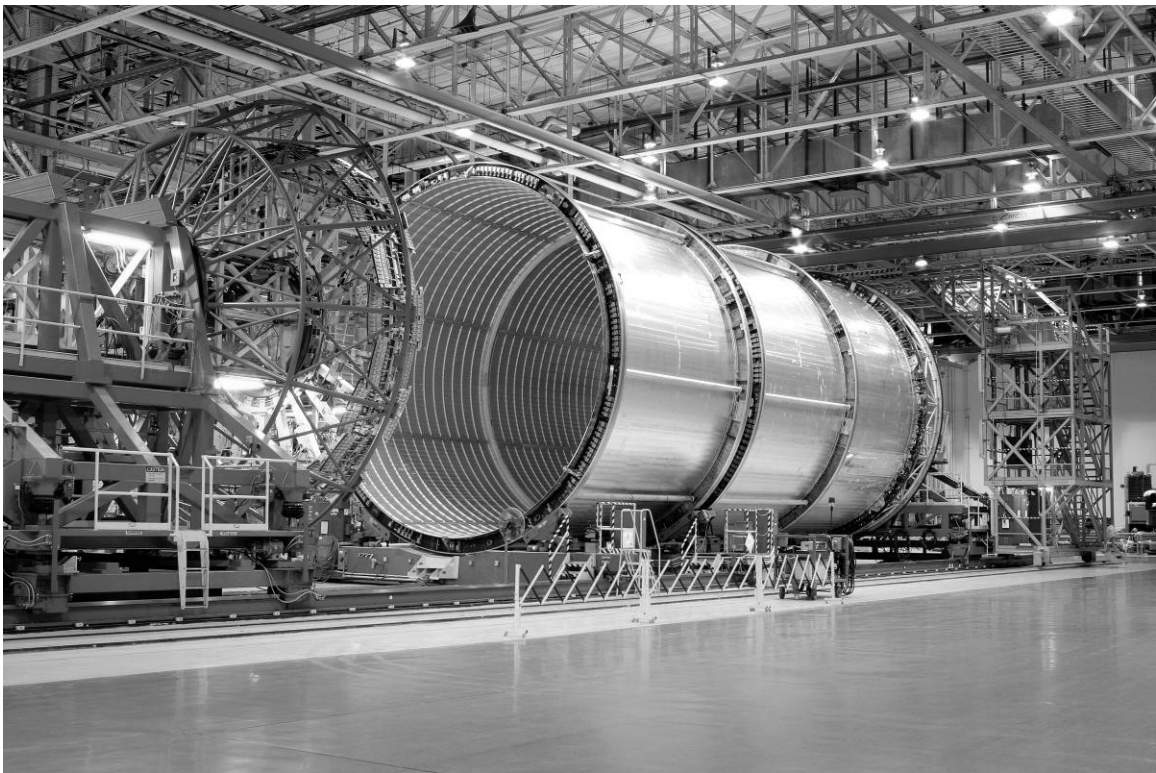

Figure D-32. LH2 tank on the 5068 weld tool at MAF, unknown date.
Source: NASA, Johnson Space Center, Imagery Online, jsc2010e009754.



Figure D-33. LO2/intertank combination for ET-138 in Cell H at MAF,
November 12, 2009.
Source: NASA, Johnson Space Center, Imagery Online, jsc2010e009722.



Figure D-34. LO2/intertank combination being moved to Cell A at MAF for stacking on top of the LH2 tank to complete ET-133, February 4, 2009.

Source: NASA, Johnson Space Center, Imagery Online, jsc2010e009741.



Figure D-35. ET-122 in Test & Checkout Building, October 7, 2009.
Source: <http://www.lockheedmartin.com/data/assets/ssc/michoud/PhotoGallery/ET-122-4-hi.gif>.



Figure D-36. ET-1 ready to be rolled into barge for 900-mile journey to KSC, June 29, 1979.
Source: NASA, Johnson Space Center, Imagery Online, jsc2010e009727



Figure D-37. The barge *Pegasus* carrying ET-121 being towed by SRB retrieval ship *Freedom Star*, March 9, 2005.

Source: NASA, Kennedy Space Center, KSC-05PD-0376, accessed at <http://www.nix.ksc.nasa.gov>.



Figure D-38. The first Super Lightweight Tank is transported to KSC's VAB, February 6, 1998.
Source: NASA, Kennedy Space Center, KSC-98PC-0272, accessed at
<http://www.nix.ksc.nasa.gov>.



Figure D-39. ET-135 being offloaded at KSC's Barge Terminal Facility near the VAB,
January 5, 2010.

Source: NASA Kennedy Space Center, KSC-2010-1001, accessed at
<http://mediaarchive.ksc.nasa.gov>.



Figure D-40. ET-135 being towed on its transporter to the VAB, January 5, 2010.
Source: NASA Kennedy Space Center, KSC-2010-1003, accessed at
<http://mediaarchive.ksc.nasa.gov>.



Figure D-41. ET-135 being rotated to vertical in KSC's VAB for placement into a test cell,
January 6, 2010.

Source: NASA Kennedy Space Center, KSC-2010-1063, accessed at
<http://mediaarchive.ksc.nasa.gov>.



Figure D-42. The ET for STS-114 being lifted from a test cell in KSC's VAB for mating, February 28, 2005.

Source: NASA Kennedy Space Center, KSC-05PD-0343, accessed at <http://mediaarchive.ksc.nasa.gov>.



Figure D-43. ET-29 being lowered between the SRBs in KSC's VAB for mating,
August 28, 2008.

Source: NASA Kennedy Space Center, KSC-08PD-2525, accessed at
<http://mediaarchive.ksc.nasa.gov>.

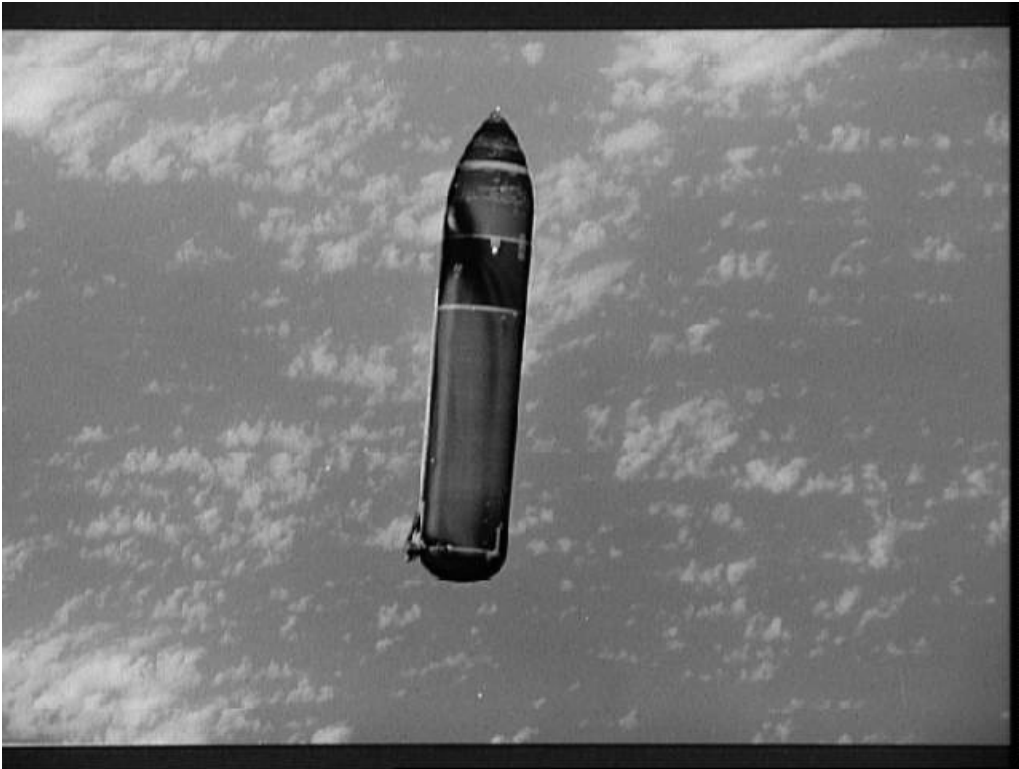

Figure D-44. *Discovery's* external fuel tank seen after being jettisoned, September 12, 1993.
Source: NASA, Johnson Space Center, STS051-22-008, accessed at
<http://www.nix.ksc.nasa.gov>.