

NASA HEADQUARTERS NACA ORAL HISTORY PROJECT
EDITED ORAL HISTORY TRANSCRIPT

ELEANOR “JERRY” JAEHNIG
INTERVIEWED BY SANDRA JOHNSON
NEWPORT NEWS, VIRGINIA – APRIL 2, 2014

JOHNSON: Today is April 2, 2014. This oral history session is being conducted with Eleanor “Jerry” Jaehnig at her home in Newport News, Virginia, as part of the NACA Oral History Project sponsored by the NASA Headquarters History Office. The interviewer is Sandra Johnson, assisted by Rebecca Wright. I want to thank you again for agreeing to talk to us today and allowing us in your home. We really appreciate it. I want to start today by talking to you a little bit about your background before the NACA, where you went to school, and when you first heard of the NACA and decided to try to come to work here.

JAEHNIG: I went to Winthrop University [Rock Hill, South Carolina]. It’s Winthrop University now. It was just Winthrop College, and it was a girls’ school. Now, it’s co-ed. I went there because my older sister went there, and I had a couple of relatives that went there. In fact, the governor’s wife went there. It was well-known as a good school. I majored in math. I wanted to major in music, but my older sister said, “You cannot major in music. You will have a hard time making a living if you’re in music. Major in math, and take your music on the side.”

So, I took her advice. I don’t know whether it was a good thing to do, because my heart was in the music, but it’s a good avocation, anyway. So, I majored in math. My family could not afford to send me to school and give me music lessons on the side. My school offered a contest—a music contest. The only thing you had to do, if you won, was promise that you would play in the orchestra. I didn’t play an instrument, but I won the contest. I got the first prize, so I

picked the cello. I got two lessons every week for the four years that I was in college, so I got my music, but I majored in math. I love it. I just love math. I'm going crazy about it all the time. Numbers are my thing. I just do everything that has numbers in it—the newspaper or anything. If there are numbers, I've got to have it. That's what I've done. I majored in math.

The way I found my job here—they had a scout out in our school. They were going to all of the universities. They came to my school, and they interviewed all of the math majors. They interviewed me and hired me right then. Even before I graduated, I had a job at NACA. I had quite a few harrowing experiences getting here, though.

JOHNSON: What were those? How did you get here?

JAEHNIG: I came on the train. There were four of us that majored in math, and they hired all four of us. We came on the train.

When we got here, we had a reservation in Hampton [Virginia], in the Hampton Hotel. We had a friend that was meeting us. When we got to the hotel, they had already given our room to somebody else, so we didn't have a room. They put us in a big, big, old, colonial home. I think it was something like four stories high. The only room they had was on the top floor. There were windows on all four sides, and none of them had screens on them. It was hot as Hades, so we had to have the windows open.

I was so homesick. The pigeons would fly in one window and fly across the room and out the other. We were all in the one room, and we took turns swatting the pigeons out of the windows. I had the worst headache I've had in my whole life, and I wanted to go home so badly.

My mother had bought me all of these pretty, new clothes to wear. One of the girls' luggage got lost, I loaned her my clothes, so she wore my new clothes before I did.

JOHNSON: How long were you in that room?

JAEHNIG: About a week. Then, we finally got a newspaper, looked at "for rent" ads and we got on a bus and went to where the Chesapeake Boulevard is. It's on the river between Newport News and Norfolk. So, this room that was for rent—it was right on the boulevard, right on the water—a beautiful place. We couldn't find it, so we stopped at this big, colonial home there. This elderly man answered the door. I said he was elderly. He was probably in his sixties. When he went out on the porch and showed us where to go to where this house was, he said, "Now, if you don't like that place, come back, and I'll see if I can help you."

We walked around the block and went back and said, "We didn't like that place."

He said, "Well, come in and we'll have a talk." His daughter had just died. She was in her twenties. She was married to the ambassador of France, and she died in childbirth. So, they had a void that they had to fill. We had a big void that we needed to fill, and so they just took us in, like we were their children. It was just like moving into a home. It was just wonderful. Everybody was so good to us. Oh my goodness! He'd put candy bars on the floor outside our door every night so that we'd have something to take to work with us. It was just wonderful.

There was a boardinghouse just a few doors down the street, so we took all of our meals there. We had it made, but we had to ride the bus to the field—to Langley Field [Langley Research Center]. Unfortunately, I drew the graveyard shift, and so I had to go home on a bus at twelve o'clock at night by myself. Well, Woo [Cloyce E.] Matheny—that's the name of one of

the engineers in the 19-foot tunnel—often rode the bus with me. That’s where I was assigned in a 19-foot [Central Computer Pool] as a computer [Figure 1].

Now, that was back in the days when we didn’t have electric computers or calculators. I used the slide rule. It was this long, and this wide, and it had every function on it that you could possibly have. Well, I had to learn to use that, but that’s where I did all of my calculations on that slide rule. I had a lot to learn there, because I was not taught to do that in school. I definitely did not know how to use it, but my husband did everything on a slide rule. So, he helped me a lot. That’s what I did, and I was really very fortunate because I was given a lot of jobs that a lot of girls didn’t get to have. I really learned a lot of things that, otherwise, I would not have.

JOHNSON: This was in 1943. Is that when you started?

JAEHNIG: Yes, 1943. I worked for two years. I left in ’45 and got married. In those two years, I learned a lot. In fact, Richard [V.] Rhode—I don’t know whether you know who he is—he was the section head. Actually, the whole Aircraft Loads Division was under him. He finally went to Washington [DC]. Then Phil [Philip] Donely became my section head. He was very good to me. He gave me a lot of good jobs and so forth—interesting jobs. Do you know what the V-G recorders were?

JOHNSON: You mentioned that on the phone, so I was going to get you to explain that and tell me what you did with that.

JAEHNIG: A V-G recorder measures gravity and speed. The two are related quite a bit. That's what Phil Donely gave me. I was in charge of that. What I had to do—they put it on the P-40 [Warhawk “single-seat” fighter] plane. That's what the V-G recorder was put on. I would have to crawl up in the cockpit. Of course, that was in the days before girls wore slacks. The plane had to be running. You had to smoke a little glass and put it in, and that would give you a basic curve. You measured everything from that one curve. The motor had to be running on the plane when you did that. It would scratch a little line. That would be the zero [basic] curve, because you weren't going anywhere. The pilots were lined up on the side. Oh, gracious! When they turned that motor on, you can guess what happened. I was pretty embarrassed. My dress went straight up over my head.

JOHNSON: They were lined up, probably knowing what was going to happen.

JAEHNIG: They knew what was going to happen. They knew every bit of what was going to happen. I got even with them later.

JOHNSON: I definitely want to hear that!

JAEHNIG: Then, I would have to go back in the plane, take the glass out, plot the curve, and work out the equations. That was a very, very good opportunity for me, which I enjoyed. I just loved doing that. I did that for almost two years. **[Figures 2 and 2(a)]**

JOHNSON: Were there other women that were up in the planes putting things in them, or were you the only one?

JAEHNIG: I was the only one.

JOHNSON: That was quite an accomplishment for that time.

JAEHNIG: Yes, it was very unusual, but Phil Donely—he was determined that he was going to make an engineer out of me. He was so disappointed when I got married. That was okay, too, but he was always very good to me. I worked the graveyard shift a lot, and that meant I had to get on the bus at midnight and ride the bus about—oh, gracious—it seemed like at least 40 miles to where I lived, even though it was more like 7 miles. Woo Matheny lived about two blocks from where I lived. That rascal—he got on the bus with me and got off the bus with me, walked me to my door, told me goodnight, and he walked home.

JOHNSON: That was nice of him.

JAEHNIG: He did that because he did not want me to be walking at midnight by myself. So, you see—the Lord took care of me. I felt very blessed. I really did feel blessed. That's most of my career in [NACA]. I worked with the V-G recorder. They did also put me in one of the tanks [Langley Tow Tanks] one time for a short time. We had a couple of tanks where they did experiments on the water. The tanks were full of water. You probably never heard of that, but

we did have a couple of those. I did a little bit of stuff, but I don't really remember exactly what I did on them. I do remember going into the tank and taking data at that time. **[Figure 3]**

JOHNSON: That's interesting. I didn't realize they did that at Langley.

JAEHNIG: I can see it right now. It was close to the full-scale tunnel. Another thing that I had that I thought was so beneficial to me—I got acquainted with a lot of the test pilots, therefore, that opened up avenues for me to learn a lot about what they were doing.

I remember Don [Donald E.] Hewes. I don't know whether you've heard of Don. Don is the one that invented the apparatus that taught the people that went to the Moon to walk on the Moon [Reduced Gravity Simulator]. The gravity, of course, is different. Don was an engineer, he was a private pilot and a very good friend of mine, so therefore, I got to know him pretty well and what he was doing, too. He was the one who invented that apparatus.

JOHNSON: Was it like a simulator?

JAEHNIG: Yes. It was on the West Area of the field, but there was a big, big space. The test pilots were the people that used it. They put a harness around them so that the gravity was different, so therefore, they simulated the conditions that it would be on the Moon. Don is the one who invented it—he was lying on the sofa, he said, when he thought of it.

JOHNSON: You never know where that's going to hit.

JAEHNIG: You never know what's coming through his head, too. I knew Don very well. He was a singer, too.

JOHNSON: Was he?

JAEHNIG: Yes, we sang a lot together, so I knew him a lot. His wife was one of my best friends. She just died about a year ago. Don built his own plane and put a Volkswagen engine in it. They flew that plane all over the country. It's amazing. They found him lying under that plane [at Patrick Henry Airport], dead [he had a heart attack]. That's how he died—where he wanted to be.

JOHNSON: Doing what he wanted to do, I'm sure.

JAEHNIG: You've just about got my whole story.

JOHNSON: You were fresh out of college and relatively young. What did your family think when you were going to get on this train and come all of the way to Hampton by yourself? Well, you had other people, but young girls travelling and then not really knowing what you were coming to.

JAEHNIG: Well, you know, my daddy was a pharmacist. He had two drugstores. It was a tough life, because it was back in the days—it was during the Depression, and so, therefore, they were happy I had a job. That's the honest truth. They were just happy that I had a job and that I could

support myself. In those days, we didn't have to worry about our safety. You didn't. I never felt threatened or anything—never. Therefore, I felt that I was perfectly safe everywhere I went. It never occurred to me that I could have been in any danger.

I had a job that paid well and that was interesting. I was never bored. I was fortunate that I had people that were over me that gave me credit for having some sense.

JOHNSON: Even today, women have problems with that.

JAEHNIG: Never—in that division, we were always given the greatest respect. They gave us jobs that really gave us some credit. They really did. I felt very, very fortunate that way.

JOHNSON: Do you remember what your salary was when you first started?

JAEHNIG: I can remember the first one. It was 60 dollars a month.

JOHNSON: Oh my goodness! You were excited, weren't you?

JAEHNIG: That was a lot of money!

JOHNSON: When you first came here, coming from South Carolina and then coming to this area but arriving at Langley, and the wind tunnels and that sort of thing, what were your first impressions of what you had walked into?

JAEHNIG: I was probably pretty much awestruck, overwhelmed quite a bit, and I would go to this huge tunnel—the 16-foot [16-foot High Speed Tunnel]. The 19-foot was in the East Area. This one was over on the West Area. Anyway, I went inside of that thing and looked at the propeller. I was amazed. That thing was big. I had no idea it was that big. Boy, when they put the air going through that thing, it was a lot of air.

JOHNSON: So, you were there from '43 to '45? You met your husband there?

JAEHNIG: Yes.

JOHNSON: What was he doing?

JAEHNIG: He was an engineer. He was a civil engineer and some of his work involved wind tunnel design. He was also a project engineer for the Jefferson Lab [Thomas Jefferson National Accelerator Facility]. You know what the Jefferson Lab is. That's here, but the universities took it over. He was in charge of that construction when they were building it. That job just about finished him off. He was really worn out when that thing was finished, but he travelled all over. There were two other cyclotrons in this country. One was in California, and one was in the Midwest. I can't remember where, though, but he had to visit them quite a bit.

He was gone a lot. He just practically lived over there at the construction site. Then, when the universities took it over, he got out of the picture altogether. He was head of the whole project, which was a big, big job. He was a smart man. You would never know it, though,

because he never flaunted it. He was a very quiet type of person, but he knew what was going on all of the time. I think he helped me a lot with that dadgum slide rule.

I can remember we [women computers] did not have a calculator. We finally got a Monroe, which did adding and subtracting. Then, finally, we got a Friden, and that did multiplication and division and did the square roots and all that kind of stuff. We were fighting over those things. **[Figure 4]**

JOHNSON: Were you?

JAEHNIG: Yes.

JOHNSON: How many other mathematicians or computers worked in your area where you worked?

JAEHNIG: The 19-foot was the Central Computer Pool **[Figure 1]**. That's really what it was. I would say—oh, golly—10 or 15 altogether in the whole office. We were given different jobs to work on. We shared a desk with somebody else. We didn't have our own desk. There were two people to a desk. I can remember the one that had shared mine. Oh, boy, was he a dilly!

JOHNSON: Was he a mathematician also?

JAEHNIG: No. He was not really well-educated. He did equations, but he was not an engineer.

JOHNSON: So, there were some men that were doing the same type of job that you were doing?

JAEHNIG: Yes. There were very few girls at NACA.

JOHNSON: When you started?

JAEHNIG: Yes. Usually, back in those days, everybody went into the computer pool first, and then you were fed out into different sections after you had your basic training. I stayed in the 19-foot for a very short time. Then, Phil Donely took me over. He did a lot for me. He really gave me a lot of responsible jobs.

JOHNSON: Were you the only mathematician, at that time, working for him?

JAEHNIG: I think, probably so, but I don't remember exactly. There were not very many girls in there. There were some. We have a couple of computers living here—Dot Coleman. She lived on my street. Now, Dot's health is not good. She went there the same time I did. We both lived on Kecoughtan Road at one time. Do you know where that is? That's in Hampton. They had an apartment—she and another girl that lived together. They had an apartment on Kecoughtan Road.

I later lived in South Hampton in one of the apartments, but those were not built when we first moved here. We just had to rent a room from somebody. Most of it was right around the Chesapeake Boulevard, in that area. We all had to ride buses to and from work to the Langley Field. That seemed like a long ride—believe me—a long one, especially if you're doing it at

midnight. We did take our turns at the midnight shift. We had several shifts. I pulled my share of the midnight shift, but I didn't mind it. I liked the shift, because it was quiet, and you got your work done. That was fine. I didn't mind that at all.

JOHNSON: You said you got even with those pilots. I was just wondering if you would tell us how you got even with them—the ones that were watching you.

JAEHNIG: That was a pilot that I got even with. He rode a motorcycle. He asked me to ride the motorcycle with him. It was a cold day. I'll never forget it. I didn't have any gloves, I didn't have a hat or scarf or anything. I was sitting on the back of that motorcycle, and we were going out to the air field. I was so cold, so I got somebody to take me home in their car, and he got so mad at me. I'll never forget that.

JOHNSON: That's quite a story.

JAEHNIG: Jack [John P.] Reeder was a test pilot. I knew him. I taught all of his children in school. I got situated not working at NACA anymore, and I taught school. I loved teaching school. I adored it. I could do it all over again if they'd have me. That was my thing. I taught math, music, and art.

JOHNSON: What a combination!

JAEHNIG: Yes, it was wonderful.

JOHNSON: How many years did you teach?

JAEHNIG: Almost 20, and I loved every minute. I absolutely adored it. I was made to teach. I was. I think my experience of working in the field like I did made a big difference, because I taught a lot of children that wanted to go into that field. They didn't get any encouragement from anybody, but they got it from me. I think that helped a whole lot, because I had experienced it, and they could see how much I loved it, and I loved teaching. I just adored teaching, because I like children.

I taught in the neighborhood school, so no busing. [Many] walked to school. They would go home after school, change their clothes, and come back to school. They would come back in my room, and they would say, "Mrs. Jaehnig, will you come out and play with us?"

I said, "Of course. What do you want to play?" So, I'd go out on the playground and play with them. It was wonderful.

JOHNSON: What grades did you teach?

JAEHNIG: Six and seven—the hardest ones. It's the hardest age, but I adored it. I adored it. I could handle them. I could give them a dose of their own medicine. I did not have a single discipline problem. I really didn't. I just loved every minute of it. Just every minute of it—I loved it. I'd go back tomorrow if they'd have me.

JOHNSON: When you first got to Langley, were there a lot of social activities? It was during the war, so was everyone just concentrating on the work, or did they also have the social activities?

JAEHNIG: No, they had parties. There was a lot of drinking, which I didn't get involved in. There was a lot of drinking and all that kind of stuff. These people were just out of school, and they were really spreading their wings. That didn't make me happy. That didn't make me happy at all. I wasn't that type of person. There was a lot of drinking and all that, but I never got involved in all that, but it was there.

JOHNSON: How did you meet your husband?

JAEHNIG: He lived in the apartment next door to me. He was the only one that had a car, so we all went for him. He inherited a car from his grandfather. It was a Studebaker. It was a nice car, too. He did a lot of hauling around of people. He was very popular.

JOHNSON: I imagine, during that time, because it was hard to get a car during the war.

JAEHNIG: It was. We had that Studebaker for a long time after we were married. Having a car was really something.

JOHNSON: That was an interesting time. Rebecca, do you have any questions?

WRIGHT: You mentioned earlier when we were chatting that he went to war as well?

JOHNSON: He joined the service [U.S. Public Health Service – “declared to be a military service and a branch of the land and naval forces of the United States” during WWII].

JAEHNIG: Yes. He knew that he was going to be drafted. That was when they had the draft. He knew that his name was going to come up soon, so he went ahead and joined.

WRIGHT: Did you work while he was gone, or were you home?

JAEHNIG: I quit working when I got married, because I didn't have a job, and he was stationed in Mississippi. They were so backward. Oh, golly! I had a job in Mississippi, but it was nothing to do with aeronautics. I had a job as a classification agent for a cotton bale company. That was the only job you could have. We didn't have mayonnaise. We didn't have any shoes. They were all rationed. All of the shoes were made out of cardboard. We couldn't get salad dressing. We couldn't get butter. We couldn't get anything like that, because they were using all of the grease for ammunition, so therefore, we did without a lot of stuff. That didn't make any difference to us. We didn't care. He joined the Public Health Service, even though he was not that trained. He did research work for malaria fever. That's what he was put in.

JOHNSON: He was a civil engineer, doing research work on malaria. How interesting!

JAEHNIG: He got malaria. He did. Yes, he caught malaria. I never will forget it. I thought he'd never get well, but he got it from fooling around with doing experiments with mosquitoes. That's what they put him on. That's the way that the government does though.

JOHNSON: I guess so.

JAEHNIG: He stayed just long enough after the war was over, he got out. His former professor offered him a job teaching at the University of Wisconsin. He taught surveying. That's the way it was.

JOHNSON: When did you come back here?

JAEHNIG: We came back here when it got so cold I couldn't take it anymore. You go outside, and it's 20 [degrees] below every night. You wash a diaper, and it freezes before you can put it on the line. It was stiff as a board before you put it on the line. I had to walk as far as from here to the highway to go to the bathroom, but I was happy. I was happy. I was not unhappy a bit.

I can remember one night. We heard this sniffing in our tent. I quickly got up. He said, "Do you have anything to eat in here?"

I said, "Yeah, I've got a candy bar."

He said, "Give it to him." It was a raccoon. So, I got my candy bar and gave it to that dumb raccoon. We were lucky. We had a floor in our tent, but the top was canvas, and all of these daddy longlegs crawling everywhere. I'll never forget them. It was hard.

JOHNSON: But, you made it through.

JAEHNIG: We were happy. You learned to be happy, I don't care what your situation is. You learned to be happy, and so it didn't matter to us. You'd just adjust.

JOHNSON: You started teaching when you came back here? Is that when you started, after you had your children?

JAEHNIG: Yes, after my children, I decided I was not going to teach until my children were big enough to come home, and if I'm not there, they'd be okay. They were in the fourth and eighth grades before I started teaching. It was the right thing for me. I loved teaching. I'd go back tomorrow if they'd have me. I really loved teaching.

JOHNSON: Is there anything we haven't talked about that you'd like to talk about, or any other experiences, anecdotes, or anything you want to share during your time there?

JAEHNIG: I'll think of a million things tonight. I hope I haven't disappointed you.

JOHNSON: No, not at all. You've told us some things that are pretty interesting.

WRIGHT: Crawling up in those planes. Did they ever take you on a plane trip? Did you ever get to ride in one of those planes?

JAEHNIG: No. They never took me up. I guess they were afraid I'd jump out!

WRIGHT: That wouldn't have been good.

JOHNSON: Thank you so much.

[End of interview]



Figure 1 - Human Computers; Women at NACA and early NASA. Typical computing area.

Photograph from "Human Computers" - NASA Cultural Resources (CRGIS)

http://crgis.ndc.nasa.gov/historic/Human_Computers

Figure 2 – Excerpts from:

National Advisory Committee for Aeronautics Technical Note 2194

The NACA Oil-Damped V-G Recorder, by Israel Taback (October 1950)

The effect of atmospheric turbulence on the loads encountered by aircraft in routine operational flight has for some time been studied by analyzing the records secured with the NACA V-G (velocity-gravity) recorder.

The original NACA V-G recorder in which the accelerometer unit was damped by dry friction could give satisfactory results when damped and installed in a proper manner. Acceptable records were secured if the accelerometer damping unit was adjusted correctly in each particular application. This adjustment, however, was difficult because of the requirement that the adjustment be made in the field by relatively inexperienced personnel and because changes in damping occurred with time and operating conditions.

Installation

The instrument may be attached to any accessible rigid part of the airplane structure at a location as free from engine vibration and as near the center of gravity of the airplane as possible.

Loading

- (1) Remove the circular cover above the name plate by releasing the spring hold-down lever. In order to loosen the cover plate, it may be necessary to insert a knife blade or screw driver under the pins in the cover plate and to pry gently until it is free of the instrument case.
- (2) Use tongs or a pair of pliers to grip the edges of a glass record plate and apply a thin film of lampblack to one side of the plate by passing the glass back and forth over a small, slightly sooty oil or candle flame. With a little practice, a uniform film of proper density can be applied.
- (3) Place the glass in the retaining grooves on the back of the cover plate, push in to the pin stop, and replace the cover plate in the instrument.

Handling of Records

Flight records should be carefully removed from the cover plate to avoid rubbing off any of the smoke film. The record should be placed on a slight incline and a few drops of the thin fixing lacquer supplied with the recorder should be applied with a medicine dropper to the upper edge of the record glass. Allow the lacquer to flow over the smoke film and dry of its own accord. If a sufficient amount of this lacquer is applied along the upper edge of the glass, the whole surface will be covered uniformly. Identification of each record should be scratched on the unused part of the smoke film.



Figure 2(a) – V-G Recorder – Front (above) Cover Removed (below)

NACA TN 2194

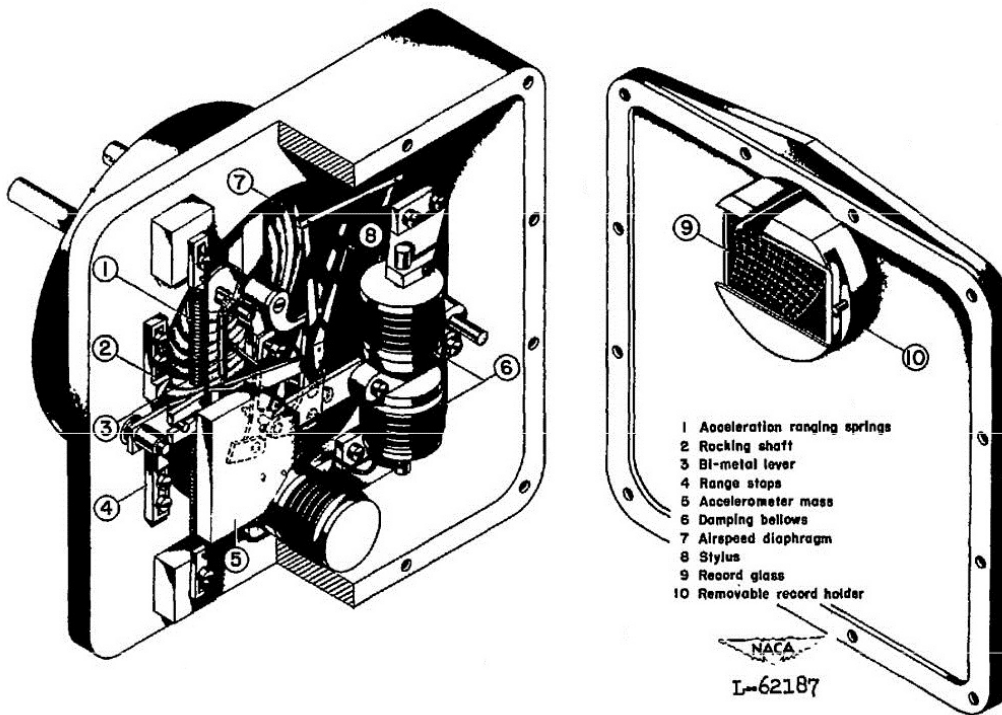
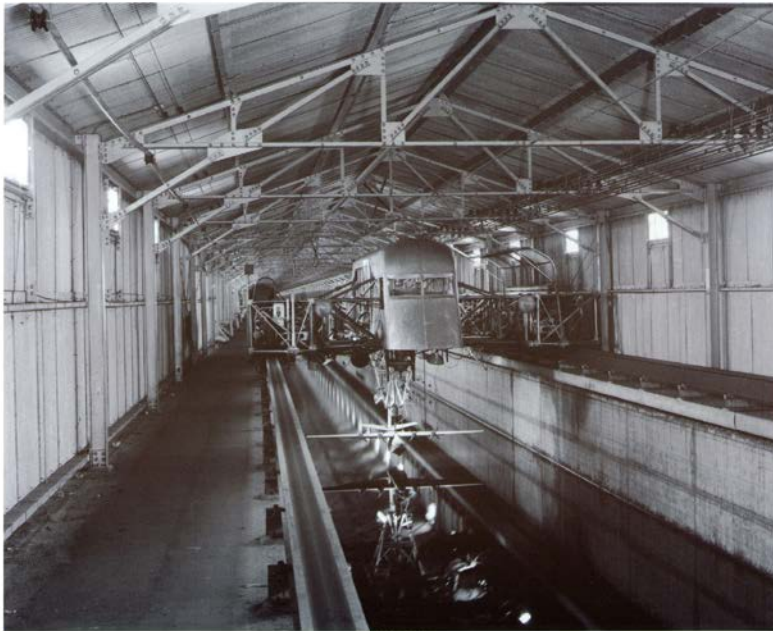

Figure 2.- Cutaway pictorial drawing of mechanical linkage in the NACA oil-damped V-G recorder.

Figure 3 – Langley Tow Tanks



L-43585

Langley Research Center
Hampton, Virginia 23061-0001

Tow Tanks (Building 720) Test Apparatus; 1945

<http://crgis.ndc.nasa.gov/historic/File:L-43585.jpg>



B-29 Ditching Test, Tow Tanks Building 720; 1946

http://crgis.ndc.nasa.gov/historic/File:1946_B-29_Ditching_Test.jpg

Figure 3 (cont.) – Langley Tow Tanks

Excerpt from: Legacy in Safety: NASA Contributions to Knowledge in Aircraft Ditching

<http://crgis.ndc.nasa.gov/crgis/images/8/85/2009Ditching.pdf>

During World War II, a major operational problem arose for the nation's military aircraft and the focus of research in Langley's towing tanks was redirected. The problem of ditching, defined as the forced landing of a land-based airplane at sea, had become a critical issue for aircraft in the European and Pacific theaters. Damaged and fuel-starved aircraft were being routinely forced to ditch at sea, and many designs lacked adequate structural design and optimized procedures for surviving the impact of the landing. In addition to structural failure and excessive (often fatal) loads transmitted to the aircrews, some aircraft rapidly nosed over into a deep dive, completely submersing the crew and preventing escape.

In 1943 the Army and Navy requested that Langley undertake a major study of ditching with a view to providing procedural recommendations to operational military units as well as to provide designers of new military aircraft with valuable data. The resulting research effort at Langley was extremely broad, including: structural tests to determine the structural load limits of actual aircraft such as the Boeing B-17 Flying Fortress, the Consolidated B-24 Liberator, and the Martin B-26 Marauder; measurement of the stresses imposed on structures during landings in calm and rough seas; and observations of aircraft behavior during ditching as replicated by free-flight models in Tow Tank 2.

Virtually every U.S. bomber and fighter configuration was evaluated in simulated ditching tests to determine the most desirable airplane attitude and configuration for ditching. Major questions required answers, such as whether to deflect wing trailing-edge flaps or extend the landing gear, whether bomb-bay doors should be opened to partially absorb the impact, and whether one wing tip should be allowed to hit the water first to slew the airplane around to absorb energy.

Figure 4 – Early “Calculators” Used by Women Computers
(photographs from “The Museum of HP Calculators”)

<http://www.hpmuseum.org/srbig.htm>



Monroe



Friden