

FLOW VISUALIZATION TECHNIQUES

Part I

by Victor I. Stevens and Alvin J. Sacks
Ames Aeronautical Laboratory

An understanding of the air flow around and through various components of an aircraft is the basic goal of all aerodynamic research. To realize this goal, it is essential that we be able to visualize the flow. Since air flow itself is not visible, considerable effort has been aimed at devising techniques for making observation of the flow possible. This is particularly true in recent years when flight speeds of interest have expanded to include the transonic and supersonic ranges and we have been presented with a number of new and previously unexplained problems. Before discussing the flow visualization techniques which have been developed, let us consider some of the things we would like to learn by their use.

Consider for a moment, the airplane shown in the first slide (A-19292-1). Depending on the particular problem under study, we may be interested in seeing the flow in a longitudinal plane or transverse plane. For example, here at this wing section we would like to know the path of air around the wing -- that is, the shape of the streamlines. The shape of these streamlines determines, to a large extent, the lift and drag characteristics of the wing and is therefore a major factor influencing the performance of the airplane. Next to the surface, a thin sheet of air is dragged along with the airplane, producing a boundary layer. We would like to know the character of this boundary layer, including the extent of the smooth laminar region, the point of transition from laminar to turbulent flow, and finally, the details of the thicker turbulent boundary layer. These factors assume considerable importance. The viscous forces in the boundary layer produce friction drag which may account for half the total drag of an airplane. These viscous forces are also responsible for aerodynamic heating which becomes important at airspeeds of twice the speed of sound and greater. The friction drag and heating of the smooth laminar layer are only about $1/5$ as great as that of the turbulent layer and we are therefore interested in means for keeping the flow laminar. When the boundary layer separates from the surface, which eventually happens with increasing angle of attack, the wing begins to lose lift. This process may be gradual or abrupt and the nature of its occurrence is important from the standpoint of safe landing characteristics as well as maximum lift.

When we study the effect of the tail on the stability of the airplane, we are interested in the flow in this transverse plane. Here we can see how the flow approaching the tail is twisted and distorted by the vortices from the wing and body. These vortices

are in effect miniature tornadoes and, although for simplicity only their cores are shown, their influence extends over the whole tail region. The stability provided by the tail in the presence of these vortices then is much different than it would be in undisturbed air. (Slide 1 off.)

The problem of making flow phenomena visible is certainly not new in the field of aerodynamic research and early efforts to solve the problem produced a number of simple flow visualization techniques. One of these methods uses filaments of smoke in the wind tunnel. We will now see a short motion picture made with this technique a number of years ago in a wind tunnel designed specifically for this purpose. The sequences shown are taken from a series illustrating methods for improving maximum lift of airfoils. While watching these movies, we should remember that for good lift effectiveness, the flow must adhere to the upper surface of the wing.

(Smoke Flow Movie)

This is a conventional airfoil model. We are looking at a longitudinal plane parallel to the direction of the flow. Filaments of smoke introduced ahead of the model are carried along by the airflow and indicate the path of the air. In general, the flow clings smoothly to the model as angle of attack is increased but at a critical angle the boundary layer separates from the upper surface, producing a turbulent wake and a loss in lift. --- This model is equipped with a retractable leading-edge slat. The smoke flow demonstrates the beneficial action of the slat in reducing the extent of the turbulent wake. For example, note that as the slat is closed the flow separates completely from the upper surface. When it reopens the flow tends to return to the surface, indicating an increase in lift. Although this change in flow pattern with slat position may at first appear slight, the associated change in lift is large. (End of movie.)

As most of you know, modern aircraft designed for high-speed flight differ considerably from the older conventional airplanes in one major respect; that is, they are generally more slender and their wing spans are much shorter compared with the length of the fuselage. From the standpoint of the aerodynamics, this generally means more interference problems, since the air influenced by the wing tips as well as by the long body often passes right over the tail surfaces. From the standpoint of flow visualization, it means a new look at the flow. That is, instead of looking at a streamwise slice out through the wing, as in the smoke movies you have just seen, we are now interested in cutting a slice across the airstream as we showed in the first slide and looking at the flow in the wake of the wings and body. Several interesting techniques have been developed for making this flow visible.

Since some of the aerodynamic ~~inter~~ferences that we want to study are primarily due to the arrangement of the aircraft and are not much affected by changes in Mach number, we have been able to gain considerable knowledge of these interferences through the use of low-speed techniques like the tuft grid and water tank methods. The use of the tuft grid which was developed in the Langley Stability Wind Tunnel is illustrated in the next movie sequence which was taken of a triangular wing model like this. (Hold up delta wing model.) These horizontal and vertical wires represent possible horizontal and vertical tail locations. The grid of tufts is located behind the model and you will be looking upstream at the model through the tuft grid.

(Tuft Grid Movie)

You are looking upstream and the wing is on the other side of the tuft grid. These are the wires representing the tail and this line represents the trailing edge of the wing. The angle of attack of the model is increasing. Note that the tufts are swirling behind each wing tip. These swirls are due to the vortices that trail behind any lifting wing and increase in strength as the angle of attack is increased. Here you can see the wing more clearly. Note that as the model is sideslipped, the tail moves into the vortex. The flow in the tail region is obviously dominated by these vortices and in many cases severe changes in both longitudinal and directional stability of the aircraft have been traced to them. Although vortices also exist on subsonic designs of large span, they are weaker and are formed further outboard so that their influence on the tail is generally small. (End of movie.)

As you might suspect, the airflow behind two wings arranged in a crossed or cruciform pattern like these (hold up second model) is complex, and interference effects between wing and tail become of primary importance in determining the stability of the aircraft. In fact, wind-tunnel tests of such arrangements show that severe irregularities in the pitch and roll characteristics are usually present. The water-tank method shown in this next film has been extremely helpful in studying this problem.

(Water-Tank Movie)

In this technique, aluminum powder is painted on the wing trailing edge and the model is lowered into a tank of water. The aluminum powder is left on the water surface and traces the wake of the wing. This first run shows the trailing vortex sheet rolling up behind a plane triangular wing. The next sequence will show a cruciform wing banked 45° and you will see that the two upper vortices come down and pass between the low lower vortices. As a result of these studies, we have been able to develop methods for predicting the path of the vortices and hence the stability of such missiles. (End of movie.)

Flights of long slender missiles have sometimes resulted in failure since the missile behaved erratically and the guidance system was unable to bring the missile on target. The cause for this, in many cases, is attributable to a body-tail interference which was revealed by the vapor screen technique. The principle of this technique, which can be employed at supersonic speeds, can be illustrated with this slide (A-19292-16(a)).

Here we see a missile model with its support and the vapor screen at right angles to the model. Supersonic airflow in the wind tunnel is from right to left as shown by this arrow. To produce the vapor screen, fog is introduced into the wind tunnel upstream of the model. A high-intensity light source placed behind a slit projects a sheet of light across the wind tunnel, thus illuminating a thin plane of the fog. Flow disturbances, such as vortices, then alter the uniformity of the fog pattern. Here we see two dark spots caused by vortices shed from the body which is at a small angle to the airstream. This dark region is a shadow of the model and has no significance as far as the airflow is concerned. In the following movie, the camera is located here, and the field of vision will include approximately this area.

(Vapor Screen Movie)

Air is flowing in this direction. This is the body and this is the body shadow which is at a right angle to the body. The angle of the body to the airstream is increasing. Note the formation of two vortices as shown by these dark spots on the lee side of the body. As the angle increases, more vortices form -- eventually they become unstable and shift in a random manner. This movement produces a corresponding change in the tail force and is responsible for the erratic behavior of the missile. (End of movie)

As a final example, I would like to show an interesting result obtained with the vapor screen method. At the top of this slide (A-19292-3(a)) we see the vapor screen pattern behind a triangular wing mounted on a long body. The model is oriented in approximately this manner. The flow is supersonic. These are the body vortices shown in the previous movie and this pattern is produced by the wing. On the basis of earlier low-speed studies and theory, one would expect to see a dark region indicating a single vortex on each side. You see, however, two vortices on each side joined by an S-shaped wake. Further examination showed that our concept of the flow was over-simplified and had to be revised for this combination of wing shape and Mach number. Using the revised concepts, the theory then predicted that the wake would roll up as shown below. Then at some distance downstream, the wake, viewed in the transverse plane, is shaped as shown here and is essentially that observed in the wind tunnel.

The methods you have just seen are useful for studying flow phenomena in the transverse plane for both low-speed and high-speed flight of slender shapes. However, if the flow is to be studied in a streamwise plane, the smoke technique shown earlier is not practical for transonic and supersonic speeds and new techniques are required.

The next speaker, Mr. Stalder, will discuss methods particularly suited for such studies.

Flow Visualization Techniques - Part II

by

Jackson H. Stalder
Ames Aeronautical Laboratory

and

Charles J. Michels
Lewis Flight Propulsion Laboratory

Fortunately, the variations in air density throughout the flow at transonic and supersonic speeds are sufficiently large to bend light rays in much the same manner as does the glass in a lens so that it has been possible to adapt optical methods to flow visualization.

The shadow method is the simplest of the optical techniques and is the one commonly observed. You have probably seen shadows of heat waves formed by the sun. These heat waves are often seen on the floor of a room where the sun's rays pass directly over a hot radiator. A typical shadow system can be illustrated with these components. The light source (left of stage) in this case is a high-intensity zirconium arc lamp. The rays from this source are collected by a parabolic mirror (suspended from ceiling in front of left stage) and reflected in parallel rays through the test section to a screen or a photographic plate. If we place a cigarette lighter at this point (drop lighter) you can see the shadow of the lighter, and more important, the shadow cast by the changes in air density in the heated region around the flame. Very similar shadows are produced by shock waves and boundary layers in transonic and supersonic air flow. The shadow method is extensively used in boundary-layer studies.

This slide (A-19292-3) shows a typical shadowgraph of a research model in flight at a speed of 2500 miles per hour, in the Ames Supersonic Free-Flight Wind Tunnel. The shadowgraph was taken with an exposure time of less than one-millionth of a second, and shows the bow shock wave, the thin laminar boundary layer, a region of transition from laminar to turbulent flow, and finally, the thick turbulent boundary layer.

The problem of predicting the location of transition is a difficult one. Typical experimental results are shown in the next slide (A-19292-4). We found that by careful control of the surface smoothness and test conditions, we were able to achieve laminar flow (point to top photo) along the entire length of the body. However, small changes in test conditions from the ideal such as one or two degrees angle of attack (point to middle photo) could cause transition to occur well forward on the lee side of

the model. It has also been found that transition does not always remain at a given place on the model as was shown here and on the previous slide. A number of shadowgraphs have been obtained which show that turbulence may be formed in bursts as shown here. Note the laminar region between the bursts (point to bottom photo). The factors responsible for these bursts are not completely known; however, we have discovered correlation between the occurrence of bursts of turbulence and the existence of minute irregularities in shape of the body nose.

Studies on the problem of transition are continuing because of the marked effect of transition location on payload and range of airplanes and missiles. For problems involving the entire flow field, greater detail can be obtained by use of a schlieren optical system shown in the next slide (A-19292-5). This is, in effect, a shadow system with a mirror and knife edge added. You will note that up to this point the components are the same, but that at this point the shadow screen is replaced by a parabolic mirror which projects the model image on the screen in this location. The knife edge is placed at the focal point of the mirror where all of the light rays pass through a single point. It is adjusted to intercept about half of the light of all rays giving a gray background on the screen.

The next slide (A-19292-6) shows the operation of the schlieren system with air flow on. When the air flow is established, the density changes produced by shock waves and expansion regions, bend the light rays passing through them. If the ray is bent upward by a **shock** wave as shown by the solid line, the knife edge cuts off all of the light of the ray, leaving a dark line on the screen. If bent downward by an expansion of air in the tunnel, the corresponding area on the screen is brightened.

On this next slide (A-19292-7) are shown two representative schlieren photographs taken of a straight and swept wing model with airflow at Mach 1.2. Here is the bow shock wave from the nose and this is the shock wave from the wing. You will note that not only is the wave itself shown, as in the case of the shadowgraph, but that various shades of gray are produced behind the wave. This shows the primary difference in the results of the shadow and schlieren methods. The shadow method is sensitive only to abrupt changes in the air density and, hence, shows the boundaries of flow disturbance. On the other hand, the schlieren is sensitive to the rate of change of air density and thus not only indicates the boundary of the disturbance, but also gives a more detailed and quantitative picture of the flow field in the disturbed region. For example, in this photograph we see a heavy black region ahead of the wing, indicating an extensive and rapid change in density and even without benefit of force measurements we can be certain that the drag of this straight wing is much greater

than the drag of the swept wing. This ability of schlieren to indicate the existence of high drag and, more important, to indicate the source of the drag, has been very helpful in improving the performance of transonic and supersonic aircraft.

In a recent investigation in one of the Ames wind tunnels of a proposed supersonic airplane design, schlieren observations were instrumental in isolating the source of certain irregularities in the longitudinal and directional stability. The irregularity in directional stability was shown to be due to interference of the type shown on this slide (A-1929209(b)).

Here are shown the shock waves generated by the engine nacelles. Note that when the airplane is sideslipped, the tail is in the disturbed region behind one of the nacelles where the flow direction and velocity are different from free-stream conditions. In some cases this may result in significant changes in directional stability.

In the next slide (A-19292-9(a)) we see a similar type of interference between the wing and horizontal tail. When the airplane is at low angles of attack, the tail is above this trailing shock wave and consequently is in the high downwash region above the wing so that the stability contributed by the tail is small. As it passes through this wave with increasing angle of attack, it moves into a region of less downwash and the stability increases.

In the examples we have seen, schlieren has been used to examine steady flow phenomena. Certain cases exist, however, where the flow fluctuates rapidly. The next movie sequence taken at Lewis illustrates a fluctuation of flow through and around an inlet.

(Movie on) This is the inlet operating at a Mach number of approximately 1.9. The flow is steady and the waves from the inlet are weak. Note the slight billowing of the wave. This fluctuation is actually one hundred times faster than shown. When this violent fluctuation occurs the drag rises and the engine is subjected to a pressure surge. Such violent fluctuations are, of course, unacceptable and could conceivably destroy the airplane. The next sequence taken at Langley shows a similar result obtained with shadowgraph. (Movie off)

As an aid for studying flows which fluctuate rapidly in a periodic manner, a stroboscopic schlieren has been developed. In this system the light source is flashed on and off at a definite rate so that the motion appears to be slowed down or stopped. Unfortunately, flow fluctuations at transonic speeds, as in buffeting, often deviate from a pure periodic type so that the strobo-schlieren is unable to stop the motion by flashing the

light at any fixed rate. To overcome this difficulty, a system was developed at Ames which was automatically controlled by the flow fluctuation to be observed. The following movie illustrates the use of this equipment in studying high speed flow.

(Movie on) Here we see an airfoil with a blunt trailing edge. The flow is from left to right at Mach 0.8. These are vortices shedding alternately from the upper and lower surfaces. This type of wake is called a vortex street, and at high speeds causes the shock waves which are moving forward over the airfoil. Here is the same type of flow behind a circular cylinder. (Movie off)

In the schlieren examples covered so far, the rate of change of the air density controls shades of gray between white and black. Colored schlieren, developed at the National Physical Laboratory in England, in which density changes control color, is also in use. Colored schlieren is similar to black and white schlieren with the following exceptions as shown in the next slide (A-19292-12).

The simple white light source is replaced by one incorporating a prism, which, in effect, produces a distributed source composed of the color spectrum. Each ray can then be considered as composed of a number of separate colors. These rays are brought to focus at this point and pass through a slit. The slit is adjusted to let only one color pass when there are no flow disturbances. Any flow disturbance which bends the ray will then cause a different color to pass through the slit. Thus, shock waves and expansion waves are in color contrast to the background. The strength of the disturbance controls the degree of bending of the ray and, hence, the color which passes through the slit.

The following movie sequence illustrates one of the advantages of colored schlieren. (Movie on) In this sequence we see the flow field around a straight wing model as the speed is increased from subsonic to supersonic. Here the slit was adjusted to give an orange background and shock waves are now blue and expansions are red. Note the formation of shock waves as transonic flow is established. The flow is now supersonic.

In the next sequence the wing sweep is varied while the tunnel is operating. The slit was adjusted to give a background of blue-green and the prism was oriented so that expansions are blue and shocks are yellow, orange, or red, depending on the strength of the wave. In this swept position the shock wave from the wing is relatively weak. As the sweep is reduced, note the progressive change in color, indicating increasing shock strength. It is clearly easier to compare shock strengths on the basis of color rather than shades of gray. (Movie off)

In this short demonstration we have had time to give only a few representative examples of many of the aerodynamic problems that have been at least partially understood and solved with the aid of some of the techniques in regular use at the laboratories of the NACA. Many equally interesting techniques, such as the interferometer, the nitrogen afterglow used in studying shock waves and density variations in low-density flows, and the luminous lacquer and china-clay techniques for studying boundary-layer flows, have necessarily been omitted. We hope, however, that you have gained some insight into the wide range of techniques now available and of their importance in the understanding of the air flow which dictates the performance of our aircraft.

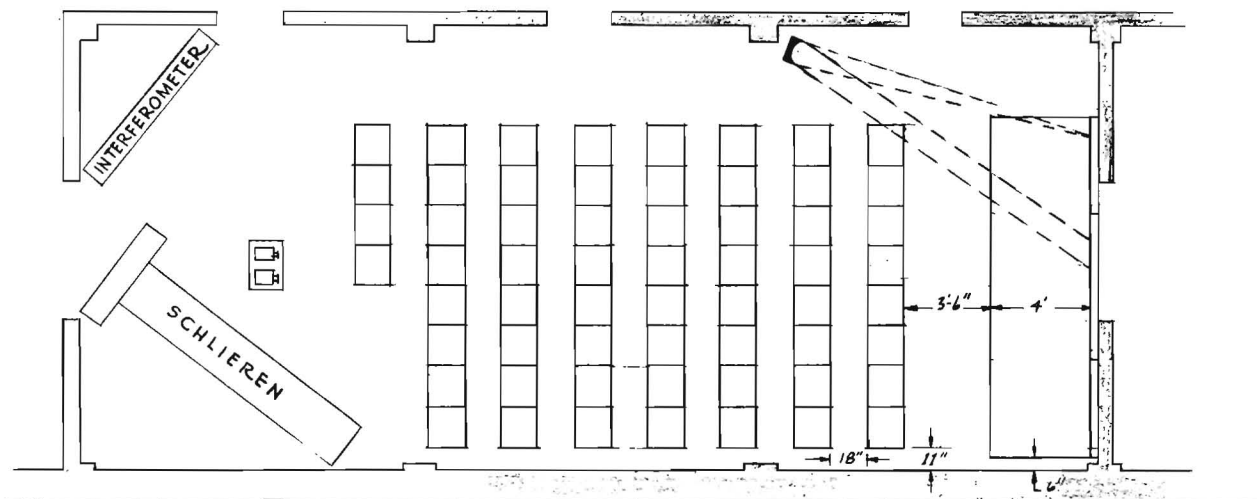

1954 INSPECTION
for AMES LABORATORY

INSTRUMENT BLDG. ROOM 11
LEWIS FLIGHT PROPULSION LAB.

SCALE $\frac{1}{4}'' = 1'-0''$
SCREEN SIZE 10' x 53"
PROJECTOR TO SCREEN - 33'
SEAT WIDTH - 20"

WMA slt/ta
① REVISION - SCREEN SIZE AD. 5/21/54



OBJECTIVES OF FLOW VISUALIZATION

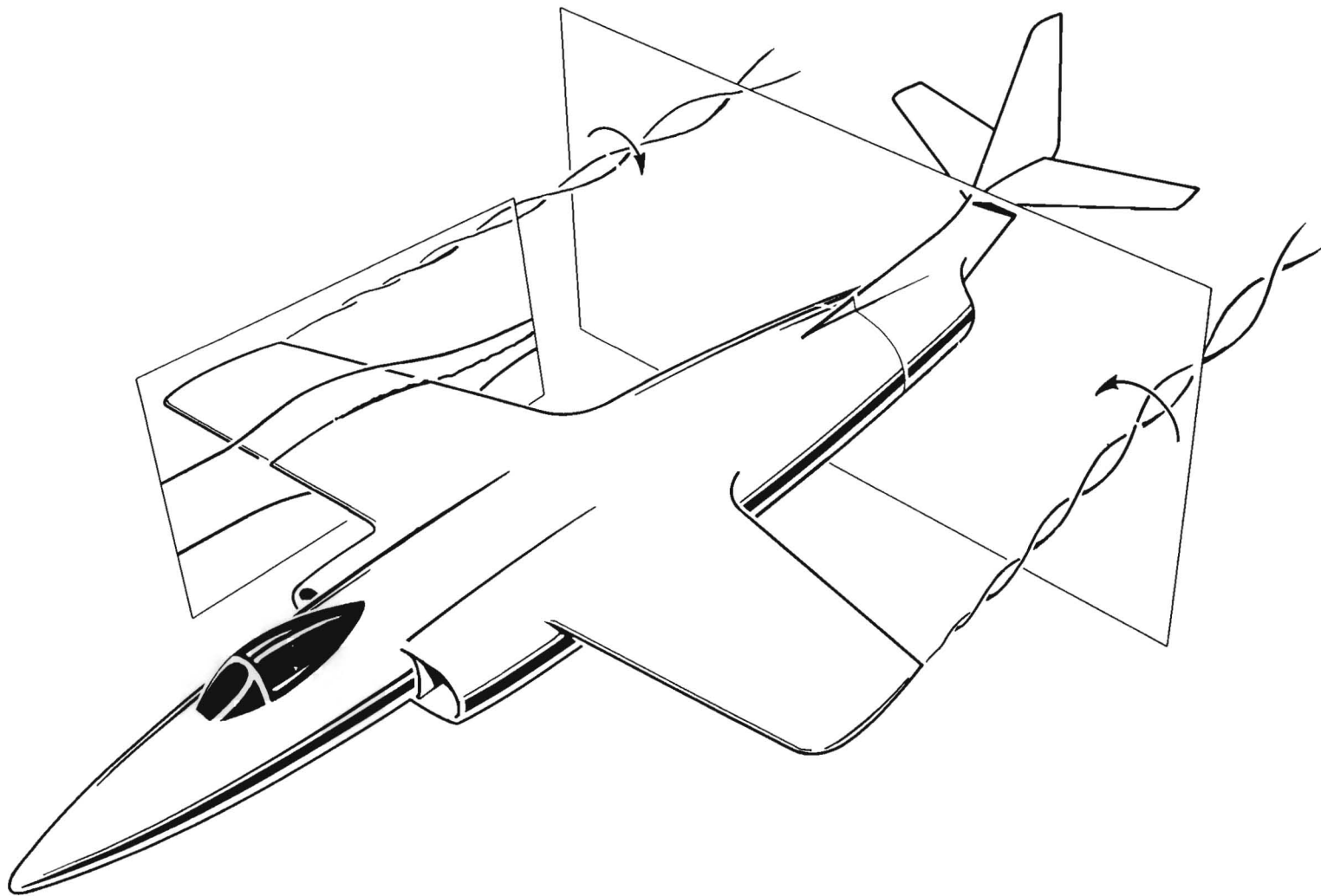

VAPOR SCREEN SYSTEM

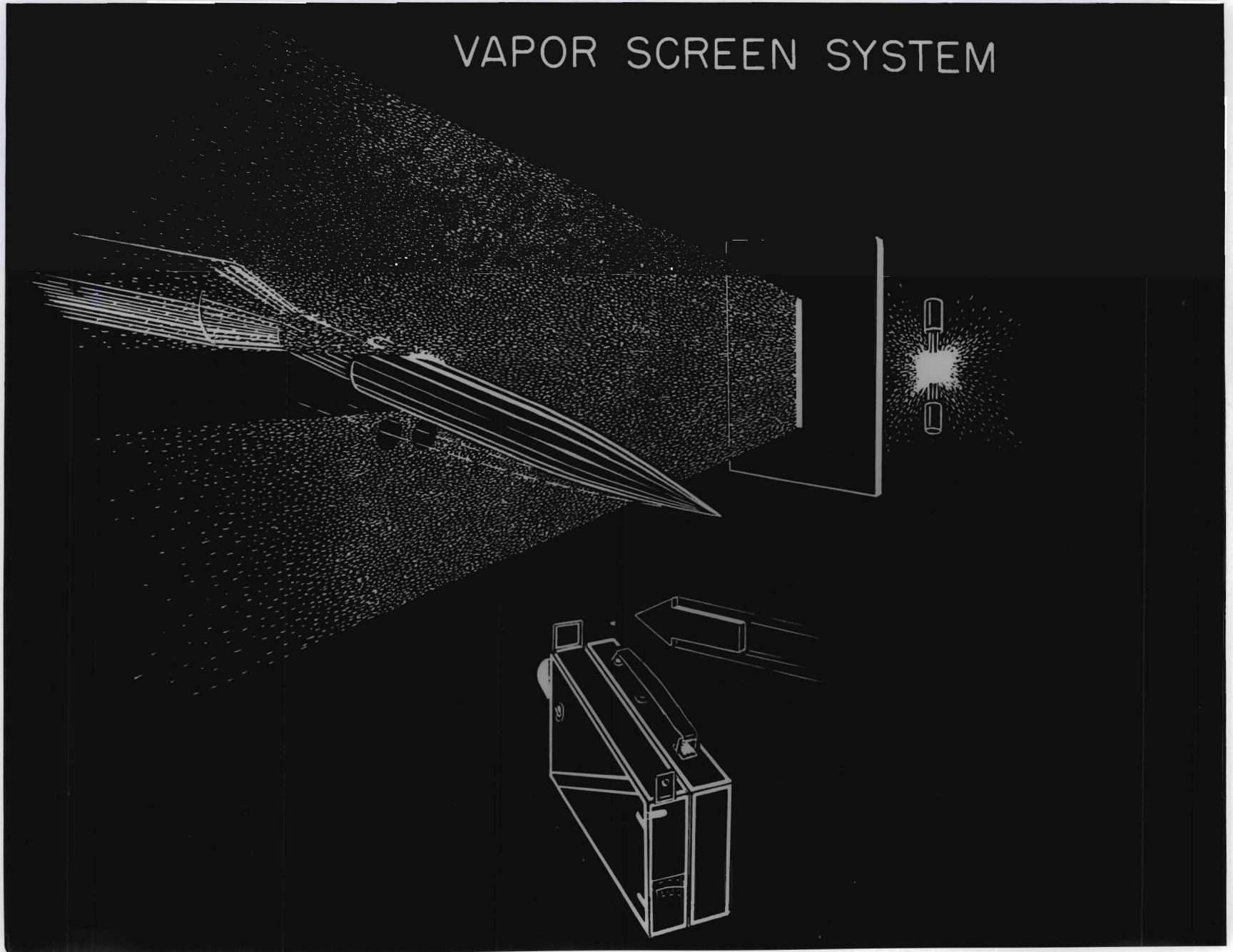

VAPOR SCREEN GUIDES THEORY



VAPOR SCREEN

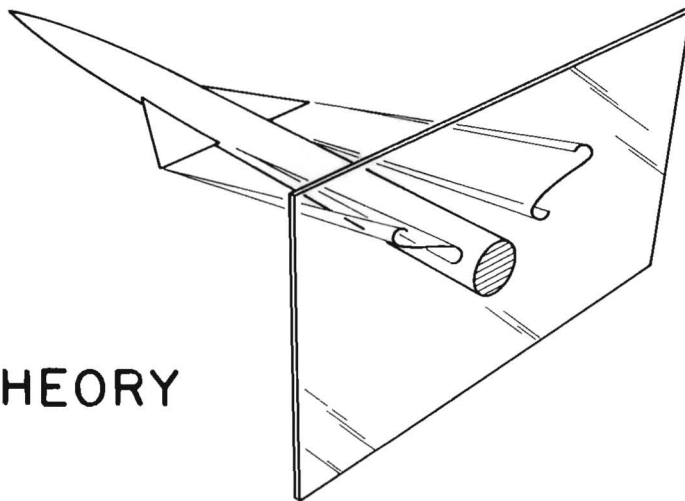

THEORY

SHADOWGRAPH OF FLOW ON MISSILE MODEL

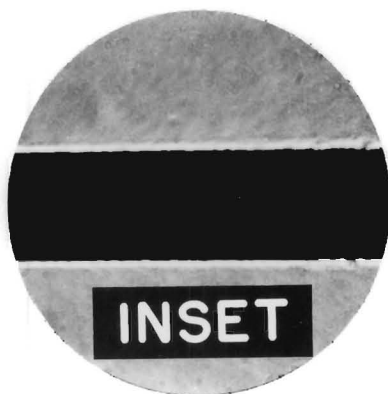
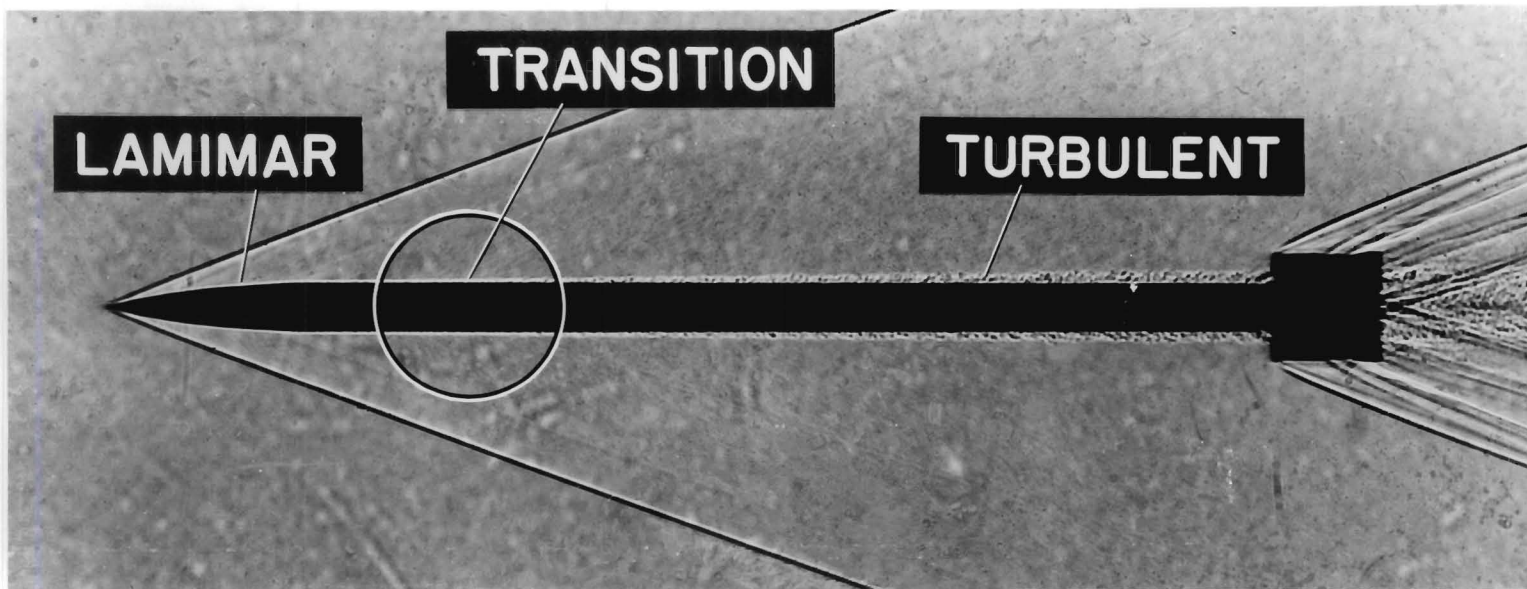

TEMPERAMENTAL NATURE OF TRANSITION

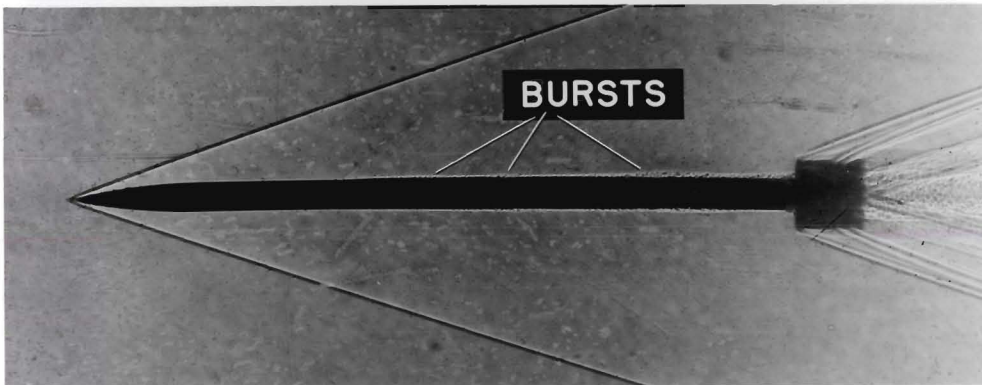
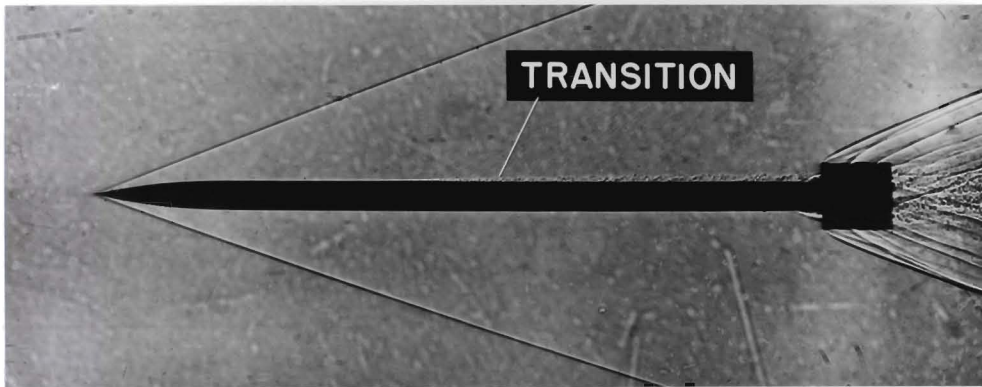
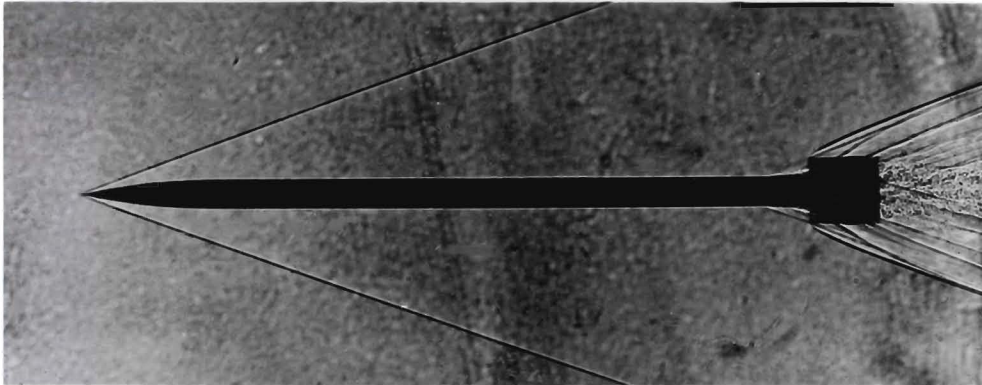

SCHLIEREN SYSTEM

Wind off

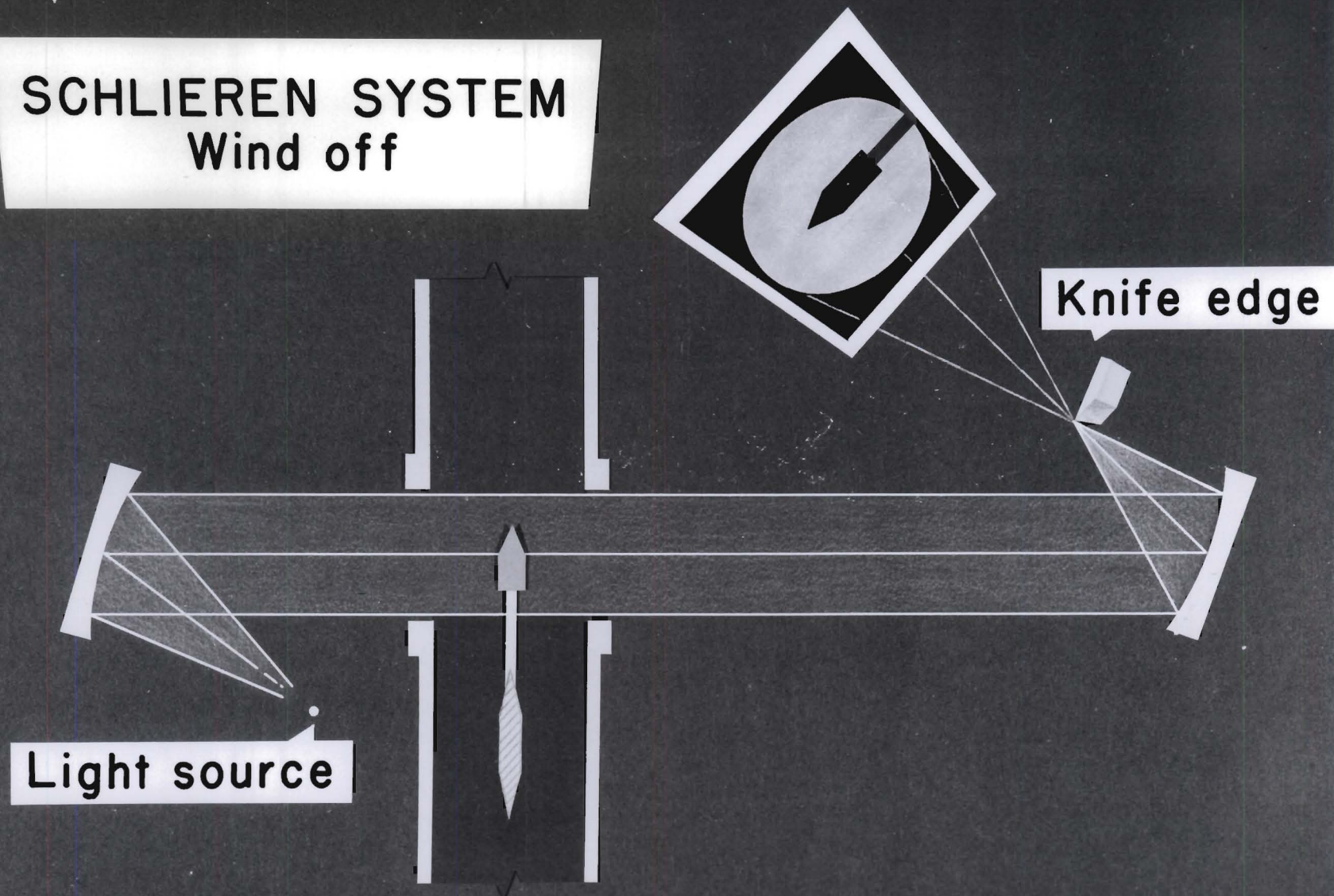

SCHLIEREN SYSTEM Wind on

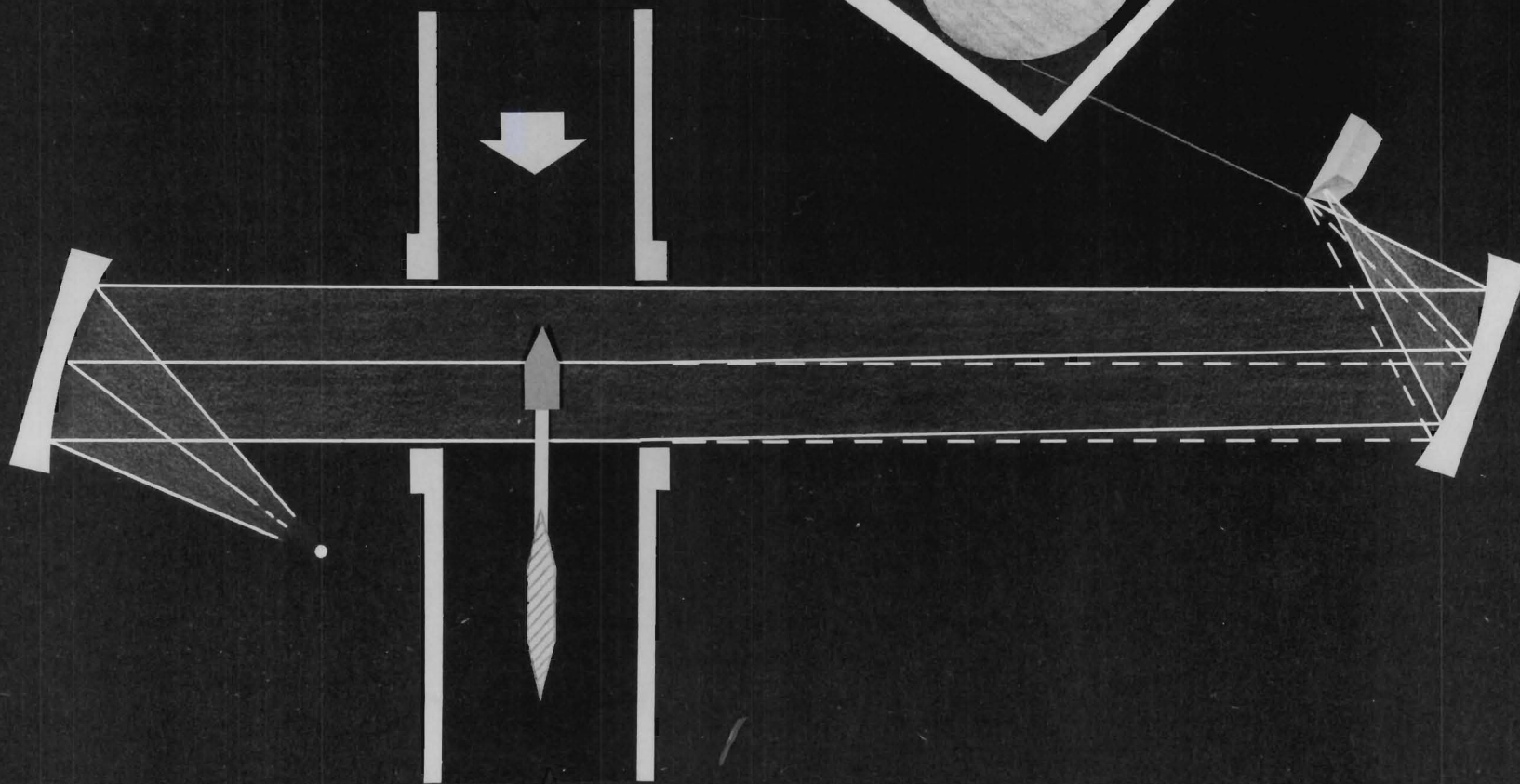
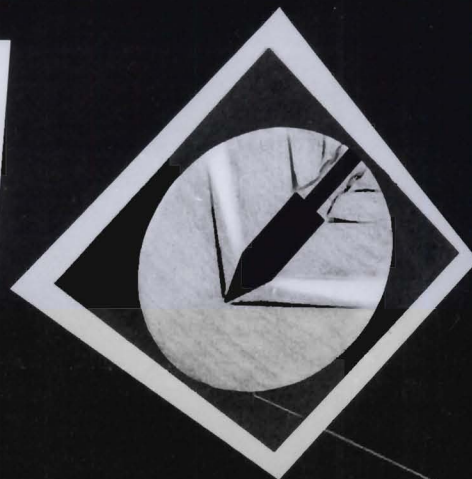

SCHLIEREN INDICATES SHOCK STRENGTH

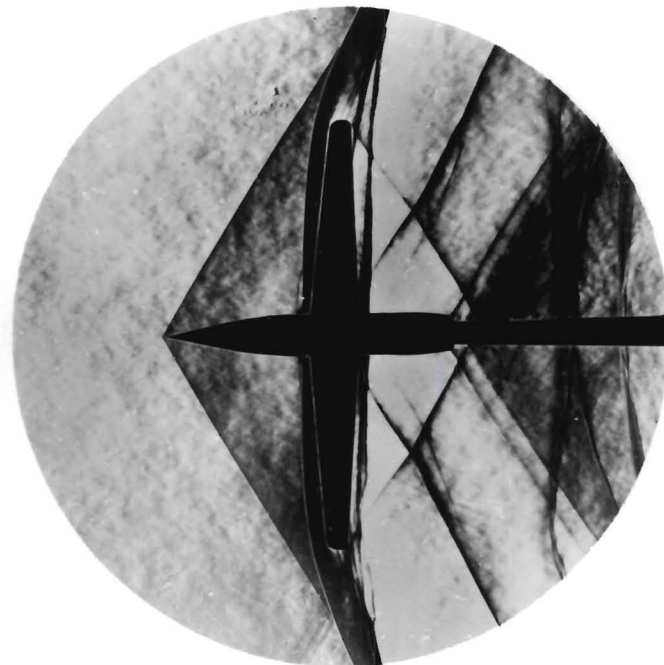
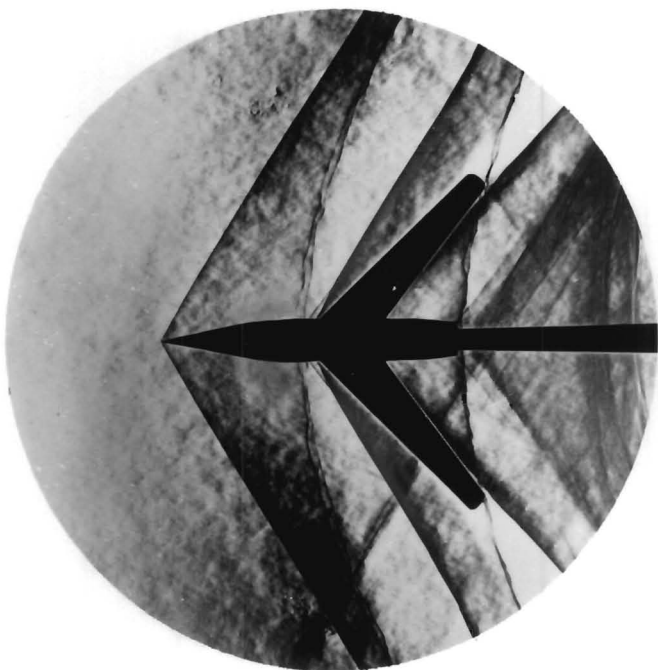

SHOCKS INFLUENCE DIRECTIONAL STABILITY

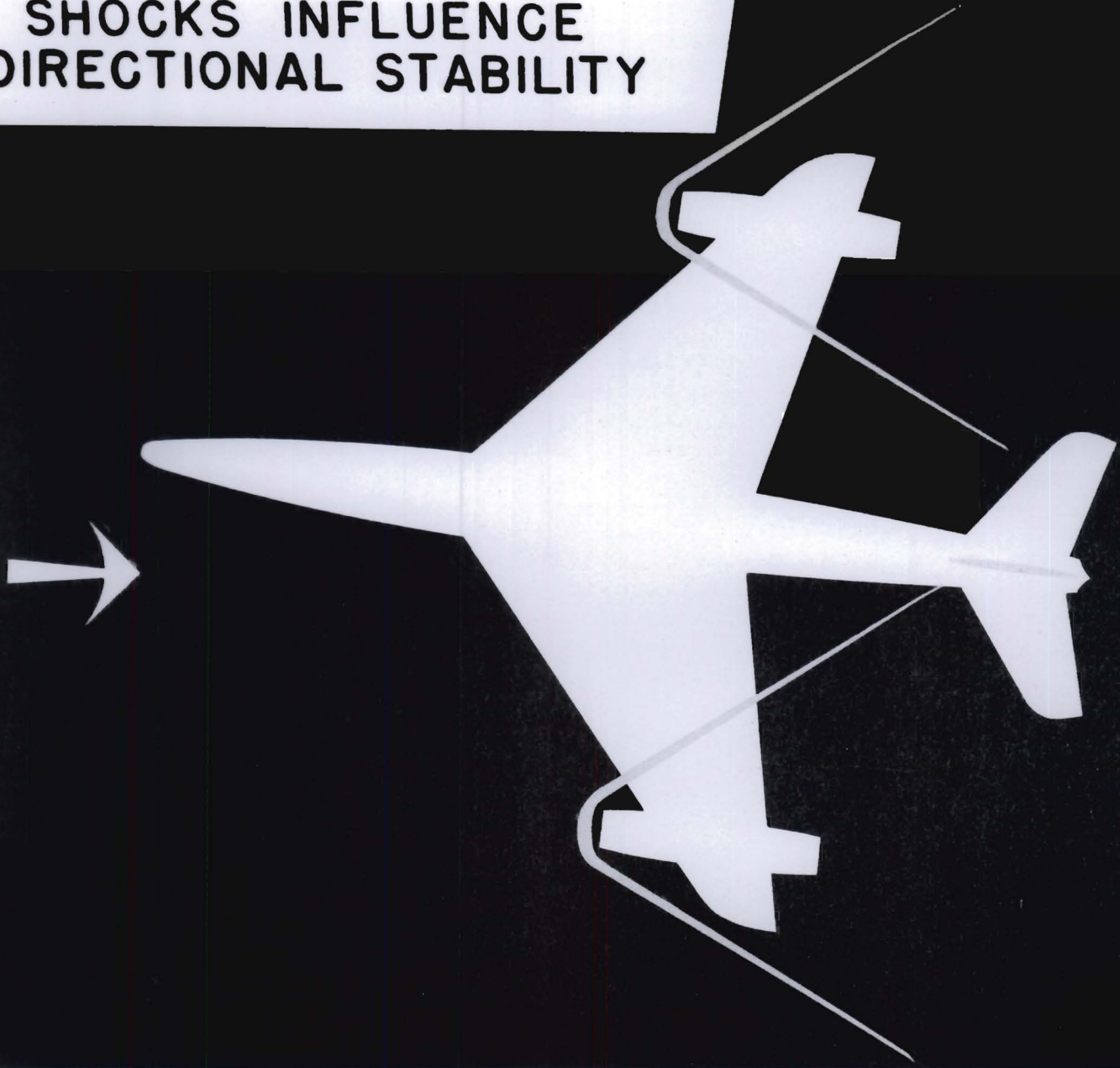

SHOCKS INFLUENCE LONGITUDINAL STABILITY

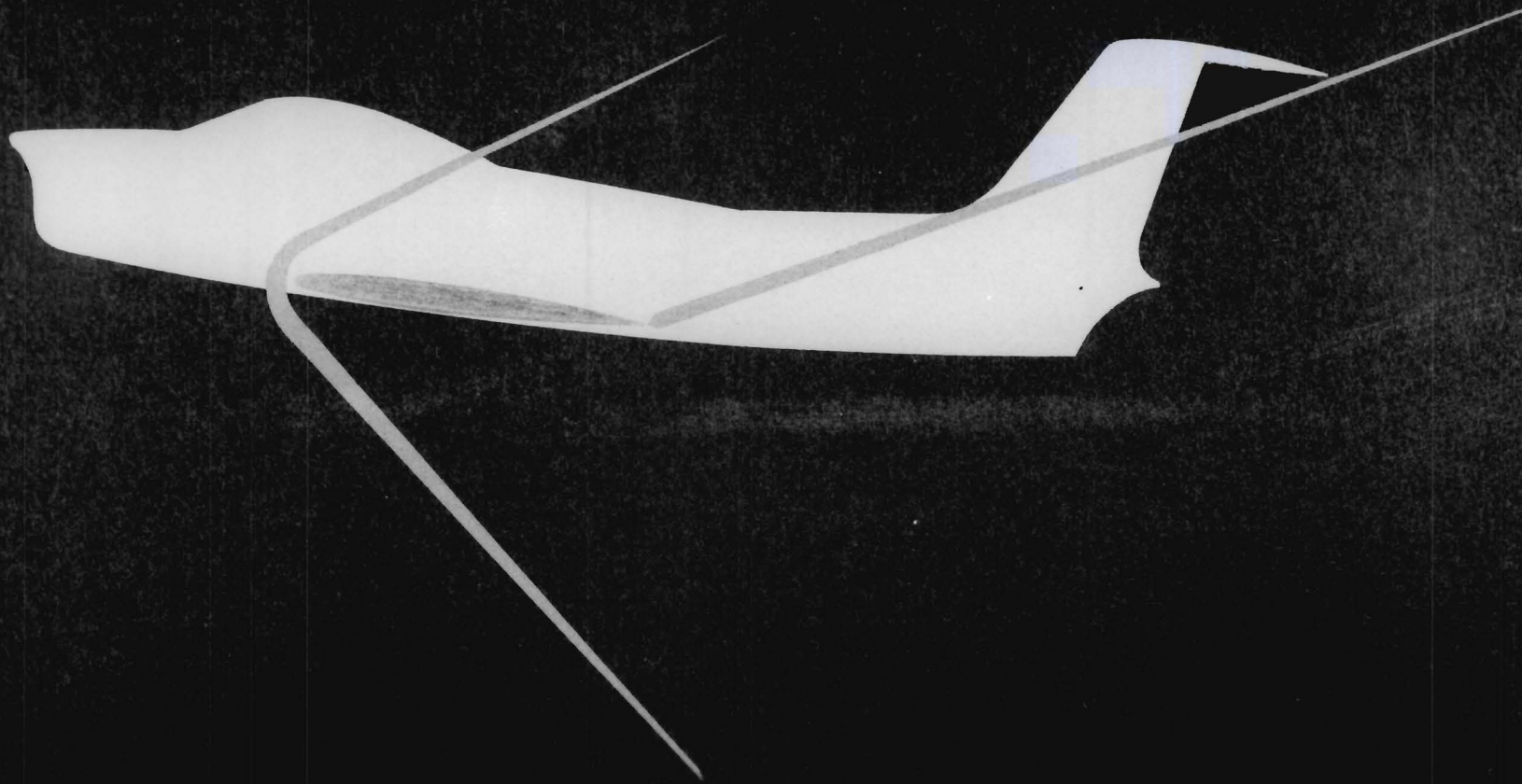

COLORED SCHLIEREN SYSTEM Wind off

