

National Aeronautics and
Space Administration

Lyndon B. Johnson Space Center
White Sands Test Facility
P.O. Box 20
Las Cruces, NM 88004-0020



July 29, 2022

Reply to Attn of: RE-22-100

Mr. Rick Shean, Bureau Chief
New Mexico Environment Department
Hazardous Waste Bureau
2905 Rodeo Park Drive East, Building 1
Santa Fe, NM 87505

Subject: NASA WSTF Remediation System Monitoring Plan Annual Update for 2022

Enclosed is the NASA WSTF Remediation System Monitoring Plan (RSMP) Annual Update for 2022 as required by Section VI.F.1 of the NASA Hazardous Waste Permit No. NM8800019434. The updated plan provides monitoring requirements for the Mid-plume Interception and Treatment System and the Plume Front Treatment System. This submittal includes an Executive Summary as Enclosure 1, a complete bound paper copy of the RSMP as Enclosure 2, and a CD-ROM with the complete RSMP in PDF as Enclosure 3.

I certify under penalty of law that this document and all attachments were prepared under my direction or supervision in accordance with a system designed to assure that qualified personnel properly gather and evaluate the information submitted. Based on my inquiry of the person or persons who manage the system, or those persons directly responsible for gathering the information, the information submitted is, to the best of my knowledge and belief, true, accurate, and complete. I am aware that there are significant penalties for submitting false information, including the possibility of fine and imprisonment for knowing violations.

If you have any questions or comments concerning this submittal, please contact Antonette Doherty of my staff at 575-202-5406.

**AMANDA
SKARSGARD** Digitally signed by
AMANDA SKARSGARD
Date: 2022.07.29
10:57:42 -06'00'

For: Timothy J. Davis
Chief, NASA Environmental Office

4 Enclosures

cc:

Mr. Gabriel Acevedo
Hazardous Waste Bureau
New Mexico Environment Department
2905 Rodeo Park Drive East, Building 1
Santa Fe, NM 87505

Ms. Melanie Sandoval
Electronic submittal through NASA Box

Executive Summary

This NASA Johnson Space Center White Sands Test Facility (WSTF) Remediation System Monitoring Plan (RSMP) includes current information relative to the operation and monitoring of the Plume Front Treatment System (PFTS) and Mid-plume Interception and Treatment System (MPITS) as of July 2022. PFTS monitoring is conducted in accordance with the NASA WSTF Hazardous Waste Permit (Permit), issued by the New Mexico Environment Department (NMED) in November 2009 (NMED, 2009). Permit Section VI.F requires that NASA develop a PFTS Monitoring Plan to set forth detailed methods, procedures, and schedules for groundwater monitoring to determine the progress and effectiveness of the PFTS. The Permit requires that NASA submit updates to the PFTS Monitoring Plan annually on or before August 1. MPITS monitoring was previously conducted in accordance with the MPITS Monitoring Plan submitted to NMED on October 30, 2008 (NASA, 2008) and a variety of internal NASA documentation. The 2012 RSMP (NASA, 2012) consolidated monitoring requirements for both active groundwater remediation systems into one document. This plan is used in conjunction with the updated WSTF Groundwater Monitoring Plan (GMP; NASA, 2022b) to ensure adequate monitoring of groundwater remediation systems at WSTF.

This Plan supersedes the monitoring-related sections of the WSTF Plume-Front Stabilization Work Plans (NASA, 1999, 2002), WSTF Plume-Front Treatment System Project Plans (NASA, 2004, 2006), WSTF Mid-plume Interception and Treatment System Monitoring Plan (NASA, 2008), and the Plume Front Treatment System Monitoring Plan (NASA, 2010), including updates.

Significant activities at the PFTS and changes that impacted the PFTS since the 2021 RSMP Update (NASA, 2021) include the following.

- NASA continued efforts to identify and implement options the recovery of equipment presently lodged in well PFI-1.
- NASA completed the planned replacement of a section of recirculation piping, which contains predominantly stagnant water and had developed a pinhole leak. Subsequent ultrasonic wall thickness testing conducted on the remaining sections of the treatment system pipe did not identify any other pipe sections having significant loss of wall thickness due to corrosion.
- NASA performed planned well rehabilitation work at wells PFE-1, PFI-2, PFI-3, and PFI-4. NASA identified corrosion on the pump for PFI-2 and developed plans to replace the pumps at both PFI-2 and PFI-4 because the pumps are of the same make and age.
- Downhole equipment failed in wells PFE-1, PFE-3, and PFI-4 in January 2022, December 2021, and April 2022, respectively. NASA began planning to replace pumps and motors in these wells (along with well PFI-2 and PFI-3) and completed engineering analyses for the selection replacement pumps and motor. NASA expects to replace the components in the third quarter 2022.
- NASA performed a comprehensive update of the site groundwater flow model to evaluate the effects of various extraction well flow and injection well flow scenarios on groundwater contaminant capture. Modeling results were validated by comparison to NMOSE monthly reported data from 2007 to present.

Significant activities at the MPITS and changes that impacted the MPITS since the 2021 RSMP Update include the following.

- Replaced the submersible motor in well MPE-9, which had been damaged by a lightning strike, and returned the well to service in January 2022.
- As a precautionary measure, NASA shut down MPITS for approximately three weeks in October 2021 in response to supply chain issues affecting the delivery of UV lamps needed for scheduled maintenance of the system.

National Aeronautics and Space Administration



Remediation System Monitoring Plan

July 2022

NM880019434

NASA Johnson Space Center White Sands Test Facility

Remediation System Monitoring Plan

July 2022

I certify under penalty of law that this document and all attachments were prepared under my direction or supervision in accordance with a system designed to assure that qualified personnel properly gather and evaluate the information submitted. Based on my inquiry of the person or persons who manage the system, or those persons directly responsible for gathering the information, the information submitted is, to the best of my knowledge and belief, true, accurate, and complete. I am aware that there are significant penalties for submitting false information, including the possibility of fine and imprisonment for knowing violations.

AMANDA
SKARSGARD

Digitally signed by
AMANDA SKARSGARD
Date: 2022.07.29
10:58:13 -06'00'

For: Timothy J. Davis
Chief, NASA Environmental Office

See Electronic Signature

Date

National Aeronautics and Space Administration

Johnson Space Center
White Sands Test Facility
12600 NASA Road
Las Cruces, NM 88012
www.nasa.gov/centers/wstf

www.nasa.gov

Executive Summary

This NASA Johnson Space Center White Sands Test Facility (WSTF) Remediation System Monitoring Plan (RSMP) includes current information relative to the operation and monitoring of the Plume Front Treatment System (PFTS) and Mid-plume Interception and Treatment System (MPITS) as of July 2022. PFTS monitoring is conducted in accordance with the NASA WSTF Hazardous Waste Permit (Permit), issued by the New Mexico Environment Department (NMED) in November 2009 (NMED, 2009). Permit Section VI.F requires that NASA develop a PFTS Monitoring Plan to set forth detailed methods, procedures, and schedules for groundwater monitoring to determine the progress and effectiveness of the PFTS. The Permit requires that NASA submit updates to the PFTS Monitoring Plan annually on or before August 1. MPITS monitoring was previously conducted in accordance with the MPITS Monitoring Plan submitted to NMED on October 30, 2008 (NASA, 2008) and a variety of internal NASA documentation. The 2012 RSMP (NASA, 2012) consolidated monitoring requirements for both active groundwater remediation systems into one document. This plan is used in conjunction with the updated WSTF Groundwater Monitoring Plan (GMP; NASA, 2022b) to ensure adequate monitoring of groundwater remediation systems at WSTF.

This Plan supersedes the monitoring-related sections of the WSTF Plume-Front Stabilization Work Plans (NASA, 1999, 2002), WSTF Plume-Front Treatment System Project Plans (NASA, 2004, 2006), WSTF Mid-plume Interception and Treatment System Monitoring Plan (NASA, 2008), and the Plume Front Treatment System Monitoring Plan (NASA, 2010), including updates.

Significant activities at the PFTS and changes that impacted the PFTS since the 2021 RSMP Update (NASA, 2021) include the following.

- NASA continued efforts to identify and implement options the recovery of equipment presently lodged in well PFI-1.
- NASA completed the planned replacement of a section of recirculation piping, which contains predominantly stagnant water and had developed a pinhole leak. Subsequent ultrasonic wall thickness testing conducted on the remaining sections of the treatment system pipe did not identify any other pipe sections having significant loss of wall thickness due to corrosion.
- NASA performed planned well rehabilitation work at wells PFE-1, PFI-2, PFI-3, and PFI-4. NASA identified corrosion on the pump for PFI-2 and developed plans to replace the pumps at both PFI-2 and PFI-4 because the pumps are of the same make and age.
- Downhole equipment failed in wells PFE-1, PFE-3, and PFI-4 in January 2022, December 2021, and April 2022, respectively. NASA began planning to replace pumps and motors in these wells (along with well PFI-2 and PFI-3) and completed engineering analyses for the selection replacement pumps and motor. NASA expects to replace the components in the third quarter 2022.
- NASA performed a comprehensive update of the site groundwater flow model to evaluate the effects of various extraction well flow and injection well flow scenarios on groundwater contaminant capture. Modeling results were validated by comparison to NMOSE monthly reported data from 2007 to present.

The use of trademarks or names of manufacturers is for accurate reporting and does not constitute an official endorsement either expressed or implied of such products or manufacturers by the National Aeronautics and Space Administration.

Significant activities at the MPITS and changes that impacted the MPITS since the 2021 RSMP Update include the following.

- Replaced the submersible motor in well MPE-9, which had been damaged by a lightning strike, and returned the well to service in January 2022.
- As a precautionary measure, NASA shut down MPITS for approximately three weeks in October 2021 in response to supply chain issues affecting the delivery of UV lamps needed for scheduled maintenance of the system.

The use of trademarks or names of manufacturers is for accurate reporting and does not constitute an official endorsement either expressed or implied of such products or manufacturers by the National Aeronautics and Space Administration.

Table of Contents

Executive Summaryiii

Table of Contents v

Abbreviations and Acronymsvii

History of Revisions and Related Documents 1

1.0 Introduction..... 3

2.0 Treatment System Regulatory Requirements..... 4

3.0 Treatment System Descriptions 4

 3.1 Plume Front Treatment System..... 4

 3.1.1 Air Stripper Information 5

 3.1.2 Water Filtration Unit..... 6

 3.1.3 UV Reactor Information 6

 3.1.4 Instrumentation and Control System..... 6

 3.1.5 Alarms..... 6

 3.2 Mid-Plume Interception and Treatment System 7

 3.2.1 Air Stripper Information 7

 3.2.2 Water Filtration Unit..... 8

 3.2.3 UV Reactor Information 8

 3.2.4 Instrumentation and Control System..... 8

 3.2.5 Alarms..... 8

 3.3 Planned PFTS Upgrades 9

 3.3.1 PFTS Effluent and Influent Equalization Tanks 9

 3.3.2 PFI Wellhead Piping Improvements 9

 3.3.3 PFTS UV Reactor and Influent Equalization Tank..... 9

 3.4 Planned MPITS Upgrades..... 9

 3.4.1 Addition of Well MPE-3 and MPE-4 to the MPITS..... 10

 3.4.2 Addition of Solids Separation Pre-treatment Process to the MPITS 10

4.0 Remediation System Operational Procedures..... 10

5.0 Waste Management Practices 10

6.0 Treatment System Monitoring 12

 6.1 Treatment System Well Performance 12

 6.1.1 Well Operational Parameters 12

 6.1.2 Miscellaneous “On Demand” Parameters 12

 6.2 Extraction and Injection Well Maintenance and Rehabilitation 13

 6.3 MPITS Infiltration Basin Maintenance..... 13

 6.4 Remediation System Groundwater Monitoring 13

6.4.1	Remediation System Influent and Effluent	14
6.4.2	Remediation System Extraction Wells.....	14
6.5	Related Groundwater Monitoring	14
6.5.1	Groundwater Monitoring Wells	14
6.5.2	Groundwater Elevations.....	14
7.0	Remediation System Performance Evaluation.....	15
7.1	Interim Measures Treatment System Goals	15
7.2	Definition of Capture Zone	15
7.3	Remediation System Effectiveness.....	16
7.3.1	Potentiometric Surface Map.....	16
7.3.2	Time-Concentration Plots	16
7.3.3	Plume Iso-concentration Maps.....	17
7.3.4	Groundwater Modeling.....	18
7.4	Activity and Changes at Sentinel Wells.....	18
7.5	Plume Capture Evaluation Methodologies.....	19
8.0	Reporting.....	19
9.0	Schedule for Review and Revision of the Plan.....	19
10.0	References.....	19
Tables	21
Table 2.1	DP-1255 Discharge Standards ¹	22
Table 3.1	PFTS Air Stripper Performance Specifications	22
Table 3.2	PFTS UV System Performance Specifications	23
Table 3.3	MPITS Air Stripper Performance Specifications.....	23
Table 3.4	MPITS UV System Performance Specifications	24
Figures	25
Figure 1.1	WSTF Location Map	26
Figure 1.2	WSTF Conceptualized TCE and NDMA Plumes and WSTF Features	27
Figure 3.1	General PFTS Layout.....	28
Figure 3.2	WSTF Remediation System Locations	29
Figure 3.3	General MPITS Layout.....	30
Appendix A	Remediation System Well Completion Diagrams.....	A-1
Appendix B	PFTS Instrumentation and Control System Features.....	B-1
Appendix C	PFTS Alarm Conditions	C-1
Appendix D	MPITS Instrumentation and Control System Features.....	D-1
Appendix E	MPITS Alarm Conditions.....	E-1

Abbreviations and Acronyms

µg/L	Micrograms per liter
µm	Micrometer
AMSL	Above Mean Sea Level
CAA	Central Accumulation Area
CFR	Code of Federal Regulations
COC	Contaminant of Concern
DP	Discharge Permit
EPA	Environmental Protection Agency
ERS	Environmental Remediation System
ft	Foot/feet
GMP	Groundwater Monitoring Plan
gpm	Gallons per minute
HART	Highway Addressable Remote Transducer
HDPE	High-density Polyethylene
HMI	Human-machine Interface
HWB	Hazardous Waste Bureau
IDW	Investigation-derived Waste
LRG	Lower Rio Grande
mi	Mile(s)
MPCA	Mid-plume Constriction Area
MPE	Mid-plume Extraction
MPITS	Mid-plume Interception and Treatment System
NASA	National Aeronautics and Space Administration
NDMA	N-Nitrosodimethylamine
NIST	National Institute of Standards and Technology
NMAC	New Mexico Administrative Code
ng/L	Nanograms per liter
NMED	New Mexico Environment Department
PCE	Tetrachloroethene
PFE	Plume Front Extraction
PFI	Plume Front Injection
PFTS	Plume Front Treatment System
PLC	Programmable Logic Controller
PMR	Periodic Monitoring Report
psi	Pounds per square inch
psig	Pounds per square inch, gauge
PVC	Polyvinyl Chloride
QA	Quality Assurance
RSMP	Remediation System Monitoring Plan
SAA	Satellite Accumulation Area
SCADA	Supervisory Control and Data Acquisition
scfm	Standard cubic feet per minute
T-C	Time-Concentration

TCE	Trichloroethene
TDSF	Treatment, Disposal, and Storage Facility
TMRP	Targeted Mobile Remediation Process
UV	Ultraviolet
VOC	Volatile Organic Compound
WSTF	NASA Johnson Space Center White Sands Test Facility

NASA White Sands Test Facility

History of Revisions and Related Documents

Date	Revision or Document
January 20, 1999	Plume Front Stabilization Work Plan (PFSWP) submitted to NMED
March 15, 2000	PFSWP approved by NMED
May 16, 2002	Modification of PFSWP submitted to NMED - Plan was not approved by NMED
March 3, 2004	Plume Front Treatment System Project Plan (PFTSPP) submitted to NMED - Plan discussed technical issues raised in NMED Request for Supplemental Information dated April 4, 2003
July 15, 2004	Revised PFTSPP submitted to NMED
November 8, 2006	Revised PFTSPP submitted to NMED
May 14, 2007	Revised PFTS approved by NMED (Approval also included March 3, 2004 submittal)
October 30, 2008	Mid-plume Interception and Treatment System Monitoring Plan submitted to NMED
June 8, 2010	Plume Front Treatment System Monitoring Plan submitted to NMED
August 26, 2010	PFTSMP approved by NMED
July 29, 2011	2011 PFTSMP Update submitted to NMED
September 22, 2011	2011 PFTSMP update approved by NMED
July 31, 2012	Remediation System Monitoring Plan submitted to NMED (RSMP includes monitoring requirements for the PFTS and the MPITS)
September 11, 2012	RSMP approved by NMED
July 31, 2013	2013 RSMP Update submitted to NMED
September 27, 2013	2013 RSMP Update approved by NMED
July 30, 2014	2014 RSMP Update submitted to NMED
December 9, 2014	2014 RSMP Update approved by NMED
July 29, 2015	2015 RSMP Update submitted to NMED
September 16, 2015	2015 RSMP Update approved by NMED
July 28, 2016	2016 RSMP Update submitted to NMED
December 9, 2016	2016 RSMP Update approved by NMED
July 27, 2017	2017 RSMP Update submitted to NMED
December 1, 2017	2017 RSMP Update approved by NMED
August 14, 2018	2018 RSMP Update submitted to NMED
February 5, 2019	2018 RSMP Update approved by NMED
July 30, 2019	2019 RSMP Update submitted to NMED
December 11, 2019	2019 RSMP Update approved by NMED
August 3, 2020	2020 RSMP Update submitted to NMED
January 25, 2021	2020 RSMP Update approved by NMED

NASA White Sands Test Facility

June 29, 2021	2021 RSMP Update submitted to NMED
November 15, 2021	2021 RSMP Update approved by NMED

1.0 Introduction

The White Sands Test Facility (WSTF) currently operates as a field test installation under the National Aeronautics and Space Administration (NASA) Lyndon B. Johnson Space Center. WSTF is a restricted access site and all activities are industrial in nature. Although the primary purpose of the facility is to provide test services and support to NASA for the United States space program, services are also provided for the Department of Defense, Department of Energy, private industry, and foreign government agencies. WSTF operates several laboratory facilities that conduct simulated use tests for space vehicles and space station materials and compatibility testing.

WSTF is located approximately 18 miles (mi) northeast of Las Cruces, New Mexico. [Figure 1.1](#) provides a vicinity map that shows the general location of WSTF relative to other dominant features and major properties in southern Doña Ana County. Groundwater at WSTF is contaminated as a result of historical operations at the site. Currently, there are no complete exposure pathways or human or ecological receptors. Downgradient public and WSTF water supply wells comprise potential future pathways for exposure to groundwater contamination. Under current conditions the nearest downgradient water use wells are WSTF water supply well K (Lower Rio Grande [LRG] 6369-S-2), WSTF water supply well M (LRG 6369-POD 4), recently installed WSTF water supply well J2 (LRG 6369-POD 5) and a private water well (LRG 6393) located downgradient of the plume and outside the westernmost WSTF boundary. Routine sampling of drinking water source water from well K and well M indicates that the WSTF water supply wells have not been impacted by WSTF groundwater contaminants. NASA has constructed and currently operates two voluntary interim measures that were designed to stabilize migration of the groundwater plume and to remove hazardous constituents from the groundwater. [Figure 1.2](#) shows the conceptualized trichloroethene (TCE) and N-Nitrosodimethylamine (NDMA) plumes (the most extensive contaminants in WSTF groundwater) in relation to relevant site features.

The Plume Front Treatment System (PFTS) is a voluntary interim measure implemented to control threats to human health and the environment through stabilization and mass removal of groundwater contamination encountered at the leading (westernmost) edge of the WSTF groundwater contaminant plume. The plume is approximately 4 mi long and 1 mi wide at its widest point and has an average depth of 700 feet (ft). The PFTS is an ex-situ pump and treat system that includes six Plume Front extraction (PFE) wells and three Plume Front injection (PFI) wells. The six extraction wells (PFE-1, PFE-2, PFE-3, PFE-4A, PFE-5, and PFE-7) are located within and immediately west of the Western Boundary Fault Zone that separates the fractured bedrock pediment aquifer (east) from the southern Jornada del Muerto Basin alluvial aquifer (west). Groundwater from the extraction well system is treated by air stripping to remove volatile organic compounds (VOCs), filtration for particulate removal, and ultraviolet (UV) photolysis for NDMA oxidation. Remediated groundwater is injected using up to three PFI wells (PFI-2, PFI-3, and PFI-4) located to the west and south of the contaminant plume in accordance with Discharge Permit (DP) Renewal and Modification, DP-1255, issued by the New Mexico Environment Department (NMED) Ground Water Quality Bureau on July 14, 2022 (NMED, 2017). The injection well locations are designed to mitigate future southern migration of the plume by creating a localized groundwater mound. This groundwater mound supports confinement of the groundwater plume to the northeast and counteracts the effects of drawdown from current and planned domestic and municipal supply wells to the south. [Figure 1.2](#) shows the location of PFTS components in relation to the facility and geological features at WSTF. On April 29, 2020, injection well PFI-1 went offline due to the failure of its submersible motor. Prior to going offline, gravel pack had been observed in water discharged to grade while backwashing PFI-1. In August 2021, NASA attempted to remove the pump and motor and inspect the well screen for potential damage. This effort was unsuccessful, and the downhole equipment was determined to be sand-locked in the PFI-1 casing, indicating that the well casing had failed and likely has placed PFI-1 permanently out of service. NASA is presently conducting research into the potential use of oilfield well

intervention and repair technologies to remove the sand-locked equipment and determine if the remaining injection wells may be subject to a similar casing failure.

The Mid-plume Interception and Treatment System (MPITS) is also a voluntary interim measure. The objective of the MPITS is to intercept and treat contaminated groundwater moving from the source areas in the WSTF industrial area toward the Plume Front area. The MPITS is installed within the Mid-plume Constriction Area (MPCA), a unique hydrogeological feature that constricts the flow of contaminated groundwater between the source areas and the Plume Front. The MPITS is an ex-situ pump and treat system that operates with up to five Mid-plume extraction (MPE) wells (MPE-1, MPE-8, MPE-9, MPE-10, and MPE-11) to remove contaminated groundwater from the fractured bedrock aquifer in the MPCA. NASA plans to add wells MPE-3 and MPE-4 to the system in the near future; increasing the number of MPE wells to seven (Section 3.3). Extracted groundwater is treated by air stripping to remove VOCs, filtration for particulate removal, and UV photolysis for the oxidation of NDMA. Remediated groundwater is discharged to an infiltration basin located near the PFI wells in accordance with DP-1255. [Figure 1.2](#) shows the location of MPITS components in relation to the facility and geological features at WSTF.

2.0 Treatment System Regulatory Requirements

This Remediation System Monitoring Plan (RSMP) was developed and will be updated annually in accordance with Section VI.F of NASA's Hazardous Waste Permit (Permit), issued by the New Mexico Environment Department (NMED; 2009). The Permit requires that NASA develop a PFTS Monitoring Plan to set forth detailed methods, procedures, and schedules for groundwater monitoring to determine the progress and effectiveness of the PFTS. In July 2012, NASA revised the PFTS Monitoring Plan to include the MPITS. The Permit and relevant subsequent NMED correspondence provide the regulatory criteria for the development and regular update of a monitoring plan for NASA's groundwater remediation systems.

NMED-issued DP-1255 (NMED, 2017) provides the regulatory requirements for discharging treated groundwater from WSTF groundwater remediation systems. DP-1255 specifies that the treatment standards for groundwater contaminants of concern (COCs): NDMA, TCE, tetrachloroethene (PCE), and chloroform shall not exceed the concentrations for tap water from the most recent version of NMED's Risk Assessment Guidance for Site Investigations and Remediation Volume I, Table A-1 Soil Screening Levels (NMED, 2022). The most recent version is dated June 2022 (NMED, 2022). [Table 2.1](#) provides the current effluent standards that must be achieved prior to the discharge of treated groundwater to the PFI wells or MPITS infiltration basin.

3.0 Treatment System Descriptions

3.1 Plume Front Treatment System

The PFTS was designed to pump and treat VOCs and nitrosamine-contaminated groundwater. Original design flow rates for each extraction well were determined based on groundwater modeling that estimated the lowest sustained groundwater extraction rate capable of containing the plume and preventing significant movement in the westward direction. Original design injection well flow rates were determined in the same manner. Subsequent refinements to the groundwater model have shown that the response of the aquifer to continued pumping justifies lower extraction flow rates than those identified during PFTS design. NASA has reduced PFTS flow rates to optimize system performance while maintaining plume capture.

The system currently utilizes extraction wells to remove contaminated groundwater. The PFE wells are secured in concrete vaults with associated piping, equipment, and instrumentation. [Appendix A](#) provides the completion diagrams for the active PFE wells. Contaminated groundwater is transported from the PFE wells to the treatment plant via sub-grade, dual-wall, high-density polyethylene (HDPE) piping. A leak detection system monitors the annular space of the dual-wall piping, the well vaults, and the pipeline manholes. This system notifies operators with a local alarm and initiates a system shutdown if a water leak is detected.

The HDPE carrier pipeline transitions to single-wall carbon steel piping at the PFTS facility (Building 650). Polyphosphate is injected at this point to inhibit scale formation in the process equipment. The groundwater flow is split equally into the two air strippers for VOC removal. Water is pumped from each air stripper sump and combined into a single steel header, which conveys the water through a cartridge filter set and then through the UV reactor to remove NDMA.

Following UV photolysis, the treated effluent is conveyed to the Injection Manifold Building (Building 651) via single walled HDPE pipe. There the flow is split into four streams that carry it to each of the respective injection wellheads. Like the PFE wells, the PFI wells are secured in concrete vaults with associated piping, equipment, and instrumentation. [Appendix A](#) provides the completion diagrams for the active PFI wells.

Building 650 is designed with a dropped floor and a floor sump that will contain significant leakage (approximately 9,120 gallons) from the piping, components, and/or treatment skids that could occur under emergency conditions. In addition, the finished floor of the electrical and control rooms is higher in elevation than the process area to prevent water from entering those rooms. A float switch in the sump triggers a system shutdown and operator notification in the event of leakage. A second higher float switch triggers a complete shutdown of power to all wells and buildings associated with the system. A pressure relief valve and rupture disc are installed in the piping upstream of the UV reactor to protect it from over-pressurization.

The following sections provide specific information about individual PFTS components or elements. The general PFTS layout is represented in [Figure 3.1](#). The location of primary PFTS components relative to other features at WSTF is shown in [Figure 3.2](#).

3.1.1 Air Stripper Information

Two sieve tray air strippers operate in a parallel configuration to treat VOCs in WSTF groundwater when the system runs at greater than half of the design flow capacity. A single air stripper can be used when the system operates at half design flow or less. Air enters the sump and travels upward through trays and water, exiting the top cover through a condensate trap. The air is discharged through vent stacks on the roof of Building 650. The air strippers must maintain an air flow rate between 3,600 standard cubic feet per minute (scfm) and 4,680 scfm in accordance with manufacturer's recommendations to ensure treatment of VOCs. Design parameters and target treatment goals are presented in [Table 3.1](#). Historical monitoring has shown that all VOCs of interest, including those not regulated by DP-1255, are effectively removed by the air strippers. High-pressure washing, using potable water, is used to remove scale from the air stripper. The existing air stripper acid descaling system is no longer used but remains in place. The water and removed scale are collected in the air stripper sumps and subsequently removed by a portable vacuum pump. Scale cleaning is generally completed twice a year, during scheduled PFTS maintenance events.

3.1.2 Water Filtration Unit

The water filtration unit consists of a pair of cylindrical stainless-steel vessels mounted on a skid located between the air strippers and the UV reactor in the treatment process. The filter vessels are operated using 1 micrometer (μm) filter elements. Each of the two filter vessels includes its own isolation valves and can accommodate full design flow of the plant. A single filter is in operation at any given time while the other remains isolated but ready for operation. Pressure transducers upstream and downstream of the filter vessels measure the differential pressure across the filters. Automated switchover control valves activate at 25 pounds per square inch (psi), and the system shuts down if the differential pressure exceeds 35 psi.

3.1.3 UV Reactor Information

The PFTS includes a Rayox^{®1} UV reactor that uses UV photolysis to destroy nitrosamine compounds (specifically NDMA) in groundwater. The UV reactor is a vertical, cylindrical, stainless-steel vessel with 12 horizontally oriented UV lamps. It is designed to operate at a minimum hydraulic flow rate of 200 gallons per minute (gpm) and a maximum flow rate of 3,000 gpm. Contaminated groundwater enters at the bottom of the vessel, flows upward past the UV lamps, and exits the top of the reactor. The UV reactor contains four irradiance sensors placed at different elevations to measure irradiance in the vessel. The sensors initiate an alarm and then a shutdown if the average of these four irradiance sensor values drops below a specified set point required for complete treatment. UV reactor design parameters are presented in [Table 3.2](#). Historical monitoring has demonstrated that NDMA concentrations in groundwater are effectively reduced to levels below the DP-1255 treatment standards (NMED, 2017) by the UV reactor.

3.1.4 Instrumentation and Control System

The treatment system is operated and monitored using a supervisory control and data acquisition (SCADA) system. The human-machine interface (HMI) consists of a Rockwell Automation^{®2} FactoryTalk^{®3} software program running on a Rockwell Automation server and stations. System operating and power usage data are collected by Rockwell Automation Historian and visualized with VantagePoint^{®4}. The FactoryTalk Site Edition software displays operation information, allows operator adjustment to operational set points and configuration (with administrative privileges), provides alarm notifications, and performs data logging and reporting. Each programmable logic controller (PLC) on the control network is programmed in relay ladder logic to control independent operations of a particular skid or subset of the treatment system. Conventional hand controls are located on equipment skids, at well vaults, and in the injection manifold building for emergency and maintenance purposes. The control system also includes electrical power monitoring and metering capabilities. A summary of specific features, components, and operational capabilities is provided in [Appendix B](#).

3.1.5 Alarms

The control system has a number of alarm conditions to identify and safeguard against malfunctions. Depending on the severity of the situation, the system may go into an amber or red alarm mode. During the amber alarm mode, the treatment system continues to function with the alarm condition(s) displayed. In the red alarm mode, a system shutdown is immediately initiated. Amber alarm conditions can transition

¹ Rayox is a registered trademark of Calgon Carbon UV Technologies LLC.

² Rockwell Automation is a registered trademark of Rockwell Automation, Inc.

³ FactoryTalk is a registered trademark of Rockwell Automation, Inc.

⁴ VantagePoint is a registered trademark of Rockwell Automation, Inc.

into red alarm conditions based on the duration and alarm set points configured for the sensors. PFTS alarm conditions are presented in [Appendix C](#).

3.2 Mid-Plume Interception and Treatment System

The MPITS is a pump and treat facility designed to provide groundwater contaminant mass removal of the relatively high concentration of NDMA between the WSTF source areas and the Plume Front. The removal of the contaminants at the MPCA is intended to minimize migration of contaminants from the source areas to the Plume Front area. The MPITS consists of groundwater extraction, treatment (for VOC and NDMA), and infiltration.

The system utilizes up to five extraction wells to remove contaminated groundwater from the MPCA. [Appendix A](#) provides the completion diagrams for the MPE wells, which are secured in above-ground enclosures. Contaminated groundwater is transported from the MPE wells to the MPITS facility (Building 655) through sub-grade dual-wall polyvinyl chloride (PVC) piping. A leak detection system monitors the well vaults and the pipeline manholes. This system notifies operators with a local alarm and initiates a system shutdown if a water leak is detected.

The PVC pipeline continues into the facility, where it transitions to single-wall PVC piping. Polyphosphate is injected into the influent for scale control in proportion to the flow rate and a static mixer is used to blend the polyphosphate with the groundwater. The groundwater is then directed to a surge tank that equalizes the flow rate prior to filtration. After passing through the filtration unit, the groundwater flow is routed through the air stripper to remove VOCs, through a second filtration unit, and through the UV reactor to destroy NDMA. Treated groundwater flows from the UV reactor to the infiltration basin through a single-wall HDPE pipeline.

The floor of Building 655 is provided with secondary containment for a volume equivalent to that in the treatment equipment and tanks installed in the building. In addition, the finished floor of the electrical and control rooms is higher in elevation than the process area to prevent water from entering those rooms. A float switch in the building's containment trench triggers a system shutdown and operator notification in the event of leakage.

The following sections provide specific information for individual MPITS components or elements. The general MPITS layout is represented in [Figure 3.3](#). The location of primary MPITS components relative to other features at WSTF is shown in [Figure 3.2](#).

3.2.1 Air Stripper Information

The MPITS includes a sieve tray air stripper designed to treat VOCs of concern in WSTF groundwater. Air enters the sump and travels upward through trays and water, exiting the top cover through a condensate trap. The air is discharged through a vent stack on the roof of Building 655. Design parameters of the air stripper and its target treatment goals are presented in [Table 3.3](#). Historical and ongoing monitoring shows that all VOCs of interest, including those not regulated by DP-1255, are effectively removed by the air stripper.

High pressure washing, using potable water, is used to remove scale from the air stripper. An existing air stripper acid descaling system is no longer used but remains in place. The water and removed scale is collected in the air stripper sump and subsequently removed by a portable vacuum pump. Scale cleaning is generally completed once a year, during scheduled MPITS maintenance events.

3.2.2 Water Filtration Unit

The MPITS includes three water filtration units. One is used to filter investigation derived waste, such as untreated groundwater, before it is placed in the MPITS surge tank and processed through the system. This unit consists of one stainless steel filtration canister with 20 µm filter elements.

Two additional water filtration units filter investigation-derived waste (IDW) and groundwater through the MPITS system using inline filter units. First, the flow is directed through a canister of 5 µm filters located between the surge tank and air stripper. After passing through the air stripper, groundwater is filtered by a second canister of 1 µm filters located between the air stripper and the UV reactor. Each of the two process filter units consists of two stainless-steel filter canisters. Only one canister is used at a time. Flow is automatically switched to a clean canister when the pressure differential between filter influent and filter effluent exceeds preset limits. Automated switchover control valves activate at 25 pounds per square inch (psi), and the system shuts down if the air stripper inlet pressure exceeds 67.5 psi.

3.2.3 UV Reactor Information

The MPITS includes a TrojanUVPhox^{®5} reactor that uses UV photolysis to destroy nitrosamine compounds (specifically NDMA) in groundwater. The UV reactor is a horizontal, cylindrical, stainless-steel vessel with 72 horizontally oriented UV lamps. It is designed to operate at a minimum hydraulic flow rate of 20 gpm, which is maintained by periodic recirculation of treated water to supplement a lower volume of extraction well water at the system surge tank. The UV reactor contains one irradiance sensor to measure irradiance in the vessel. The UV system monitors physical parameters (flow, irradiance, transmissivity, ballast power, number of operational lamps, age of lamps, etc.) to perform calculations that characterize NDMA destruction. The UV system can be operated in manual mode by adjusting the percentage of UV output, or in automatic mode where the control system automatically adjusts UV output to achieve adequate NDMA oxidation. UV reactor design parameters are presented in [Table 3.4](#). Historical and ongoing monitoring has demonstrated that NDMA concentrations in groundwater are effectively reduced to levels below the DP-1255 treatment standards by the UV reactor.

3.2.4 Instrumentation and Control System

The treatment system is operated and monitored using a Rockwell Automation SCADA system. The HMI consists of a Rockwell Automation FactoryTalk software program running on a Rockwell Automation server and workstation. The system displays equipment and treatment system operation information, allows operator adjustment to a limited range of operational set points and configuration, provides alarm notifications, and performs data logging. The main PLC on the control network is programmed in Rockwell Automation RSLogix 5000^{®6} relay ladder logic to control all functions of the process and interact with any subset of the treatment system even if the HMI is offline. Separate site-specific software applications and equipment are used to monitor electrical power. A summary of specific features, components, and operational capabilities is provided in [Appendix D](#).

3.2.5 Alarms

The system is configured to monitor the process and activate an alarm when events outside of control parameters occur. Depending on the severity rating of the events, the system will log minor, major, or critical status with the process responding appropriately. All alarms are displayed on the HMI in addition

⁵ TrojanUVPhox is a registered trademark of Trojan Technologies.

⁶ RSLogix 5000 is a registered trademark of Rockwell Automation, Inc.

to an event log that is used to troubleshoot the alarms and related sequence of events. A system shutdown is immediate when a major or critical alarm is activated. All other alarms provide advanced warning of an out of operational range event that requires attention but does not immediately affect treatability. MPITS alarm conditions are presented in [Appendix E](#).

3.3 Planned PFTS Upgrades

NASA is currently planning a PFTS upgrade project that will improve the operation and maintenance of the systems. Plans for the PFTS upgrade project will take into account the current status of PFI-1, which went of service on April 29, 2020. Extensive groundwater flow modeling of the PFTS extraction and injection systems has demonstrated that capture of the plume front can be maintained at a lower total extraction flow rate than the original design flow rate, and as a result, a replacement for PFI-1 is not needed. As a result of this finding, NASA anticipates that PFI-1 will be abandoned. The currently approved groundwater treatment process (air stripping and UV photolysis) will not be changed during this project. Planned upgrades are summarized in this section.

3.3.1 PFTS Effluent and Influent Equalization Tanks

NASA plans to install an equalization tank (20,000 to 100,000 gallons, capacity to be determined) at the PFTS effluent upstream of the PFI wells, in order to independently distribute effluent to each PFI well using the hydraulic pressure created by treated groundwater in the tank ([Figure 3.2](#)). The objectives of the effluent equalization tank are to ensure that PFI wellhead pressures remain constant, to deliver a consistent, uninterrupted flow of treated groundwater for injection at each PFI well, and to reduce injection well pressure influence at the treatment facility.

In conjunction with the PFTS UV upgrade, NASA is considering installation of an influent equalization tank. The objectives of this tank include more consistent flow through the treatment process and more flexibility in starting and shutting down the treatment process (when needed).

3.3.2 PFI Wellhead Piping Improvements

Current PFI wellhead piping is enclosed in below-grade vaults, which require special access procedures that complicate maintenance and operation activities. NASA plans to reconstruct the PFI wellhead piping in above-grade enclosures to eliminate the need for confined space entry, co-locate injection well and backwash flow meters, and add equipment to improve and automate backwashing operations. Additionally, well control and monitoring instrumentation will be secure and protected from the environment. Because the PFI wellheads will be at ground level, maintenance and repair activities can be performed more quickly and safely than current operations performed in below-grade vaults.

3.3.3 PFTS UV Reactor and Influent Equalization Tank

NASA plans to replace the PFTS UV system. Newer equipment has the potential to reduce operation and maintenance costs, reduce downtimes, and lower power cost. A UV Upgrade Market Study has been completed and system requirements are in the development and review stage of planning.

3.4 Planned MPITS Upgrades

NASA is planning two MPITS upgrade projects that are expected to increase the flow of contaminated groundwater through the MPITS and improve the pretreatment of MPITS influent. The currently approved groundwater treatment process (air stripping and UV photolysis) will not be changed during this project. Planned upgrades are summarized in this section.

3.4.1 Addition of Well MPE-3 and MPE-4 to the MPITS

In September 2021, NASA completed the Targeted Mobile Remediation Process (TMRP) Pilot Test as described in the *Targeted Mobile Remediation Process Pilot Test Work Plan* (NASA, 2019), which was approved by NMED with modifications on April 2, 2019 (NMED, 2019). In the March 8, 2022 TMRP Pilot Test Report (NASA, 2022a), NASA reported on how the TMRP pilot test was used to better characterize exploration wells MPE-3 and MPE-4 through longer duration pumping. The pilot test demonstrated that wells MPE-3 and MPE-4 could contribute up to 39% and 23% more to the current total MPITS flow, respectively. NASA also concluded that well MPE-3 could contribute as much as 78% more TCE mass and 184% more NDMA mass through MPITS. Well MPE-4 could add as much as 28% more TCE mass and 14% more NDMA mass through the treatment system (NASA, 2022a; p19).

NASA is not planning further bench or pilot scale testing because the original MPITS design easily accommodates the additional groundwater flow anticipated from wells MPE-3 and MPE-4. The existing air stripping and UV photolysis equipment will not be modified or replaced. NASA plans to configure wells MPE-3 and MPE-4 comparably to the existing MPE wells. Electrical power will be provided from the nearby electrical grid ([Figure 3.2](#)). The MPE-3 and MPE-4 wellheads will be secured in an enclosure attached to a spill containment concrete slab on grade, and wellhead piping at the wells will enter and exit the well vault concrete slab on grade. Well electrical systems, electronics, communications systems, leak detection, and other controls will be consistent with that used at other MPE wells. Downhole pumping systems are expected to be compatible with the existing treatment system and comparable to those in use at other MPE wells to maintain standardization within the system. Contaminated groundwater will be conveyed from well MPE-3 and MPE-4 to the MPITS in dual-walled piping equipped with leak detection integrated into the MPITS leak detection system.

3.4.2 Addition of Solids Separation Pre-treatment Process to the MPITS

Currently, NASA uses approved polymers to partially remove solids from IDW managed at the MPITS prior to its introduction into the system. Final solids removal is completed through the use of the existing filtration system. NASA plans to improve the solids removal process by adding pre-treatment of IDW. NASA performed engineering studies of extraction well and IDW solids accumulation and developed a conceptual design of a solids separator to accommodate IDW. The design includes a potential inclined settler that would require the addition of approved polymers to enhance separation. Additionally, NASA reviewed optional centrifugal and flat-plate separators for potential use at the MPITS. Further research is required due to the variability of solids concentration and composition.

4.0 Remediation System Operational Procedures

Procedures for the operation of the PFTS and MPITS are contained in site-specific documents. These documents contain instruction for routine start-up, operation, inspection, and maintenance of the facilities, as well as emergency shutdown and contingency procedures. The documents are updated regularly to reflect changes in operation due to lessons learned during system operations, updated system configurations or control system upgrades, and to add or remove information to keep the documents current. Remediation system operations, anomalies, and related information are recorded in the appropriate system logs and retained as part of the operational record. All documents and records are managed in accordance with established NASA procedures.

5.0 Waste Management Practices

Non-hazardous, hazardous, and universal wastes are generated during operation and maintenance of the PFTS and MPITS. Groundwater IDW generated during well installation, maintenance, and sampling

activities at WSTF is accumulated in either a Central Accumulation Area (CAA) or a Satellite Accumulation Area (SAA) prior to treatment and discharge in accordance with DP-1255 (NMED, 2017). All wastes are properly managed per 20.4 New Mexico Administrative Code (NMAC) or 20.9 and the applicable parts of 40 Code of Federal Regulations (CFR), Subchapter I. Additionally, the procedures for waste management at WSTF are contained in the most current version of the WSTF Waste Management Manual. Any off-site contractor-generated wastes will be managed in accordance with site waste management practices and all applicable federal, state, and local regulations. New waste streams will be characterized prior to generation in accordance with Permit Attachment 12, Section 6.3 (NMED, 2009).

The basic management practices for current hazardous and universal waste streams are provided below.

- Contaminated groundwater IDW generated from site-wide well and remediation system activities are accumulated in Department of Transportation-compliant containers and managed in SAAs (20.4.1.300 NMAC and 40 CFR 262.15) or CAAs (20.4.1.300 NMAC and 40 CFR 262.17). Field-portable “empty-daily” waste containers used during well sampling activities are managed within an SAA and the container is emptied at the end of the work shift at a CAA. Containerized contaminated groundwater is transported to, processed through the MPITS, and discharged in accordance with DP-1255 (NMED, 2017).
- Environmental investigation decontamination rinsate is containerized and managed as hazardous waste and managed under the SAA or CAA provisions before being transported to and processed through the MPITS in accordance with DP-1255 (NMED, 2017).
- Gloves, wipes, and other debris (40 CFR 268.2(g)) that has contacted contaminated groundwater or other materials contaminated with IDW residues are managed as hazardous waste. Contaminated debris is managed at an SAA and transferred to a CAA pending off-site shipment and disposal at a permitted RCRA Treatment, Disposal, and Storage Facility (TDSF).
- Spent water filters exposed to VOC-contaminated groundwater are managed at the point of generation in an SAA or CAA and subsequently shipped off-site for disposal at a permitted RCRA TDSF.
- Spent UV lamps are managed as universal waste for eventual off-site disposal in accordance with 40 CFR 273. Damaged UV lamps are managed as a characteristic hazardous waste (D009) and properly managed and disposal at a permitted RCRA TDSF.
- Spent scale cleaning solution is managed as a hazardous waste and processed through the MPITS. This waste stream may be subject to elementary neutralization under 40 CFR 260.10 prior to introduction to the MPITS in accordance with DP-1255 (NMED, 2017).
- Wastewater from pressure washing remediation system air strippers is stored in appropriate accumulation container(s) and managed under the SAA or CAA provisions before being transported to and processed through the MPITS. Solids generated from cleaning the air strippers are managed as a hazardous waste and disposed of properly at a permitted RCRA TDSF.
- Discarded groundwater samples containing chemical preservative or reagent not permitted to be discharged in accordance with DP-1255 are managed as a hazardous waste in an SAA or CAA prior to being sent off-site for disposal at a permitted RCRA TDSF.

Non-hazardous wastes generated at the remediation systems are managed as described below.

- Debris that has not contacted contaminated groundwater or other materials contaminated with groundwater residues is managed onsite in accordance with the New Mexico State-approved Solid Waste Management Program and is disposed of at a RCRA Subtitle D landfill.

- Spent water filters used downstream of the air-strippers at the PFTS that have not been exposed to VOC-contaminated groundwater are allowed to air dry and are then disposed of at a RCRA Subtitle D landfill.
- Water produced from the uncontaminated aquifer during PFTS injection well backwashing or from other maintenance activities downstream of the treatment process. This water may be discharged to grade in accordance with DP-1255 (NMED, 2017) or other regulatory approval documents.

6.0 Treatment System Monitoring

The following sections describe monitoring activities that are used to characterize the performance of the PFTS and MPITS and to demonstrate their effectiveness.

6.1 Treatment System Well Performance

The instrumentation and control systems for the PFTS and MPITS continually monitor and intermittently log pertinent operational parameters related to the performance of the extraction and injection wells. These parameters include extraction and injection volumetric flow rates, extraction pump power-related parameters (including current and voltage), and the water level in each extraction and injection well. The specific capacity for each extraction and injection well is calculated utilizing water levels and flow rates. The long-range trending of the specific capacities is reviewed and evaluated as an indicator of overall extraction and injection well health. Decreases in specific capacity that cannot be corrected by simple backwashing operations may warrant consideration of well rehabilitation or replacement.

6.1.1 Well Operational Parameters

Extraction and injection well performance and conditions are monitored routinely using two primary methods:

- Flow rate versus drawdown or mounding measurements (specific capacity).
- Power parameters related to the operation of pumps (current, voltage).

6.1.2 Miscellaneous “On Demand” Parameters

When operational problems occur, additional operations may be performed to better diagnose the nature of the problems and to determine subsequent remedial actions. For example:

- Downhole video logs may be performed (when practical) to provide visual verification of a well’s condition.
- Physicochemical parameters may be collected to predict scaling and corrosive conditions and plot environmental change (when practical).
- Water level measurements may be obtained from groundwater monitoring wells and/or piezometers to help determine the impact of the remediation systems on the surrounding aquifer.
- Biological testing may be performed to determine the nature and abundances of microorganisms associated with biofouling.

6.2 Extraction and Injection Well Maintenance and Rehabilitation

NASA has developed and uses internal procedural documentation to address remediation well performance evaluation, rehabilitation, and repair if necessary. This procedural documentation presents decision points and corrective actions related to the well performance decline.

During normal operations, clogging of the aquifer around the wellbore may occur due to the alignment of formation fines, buildup of biological encrustations or slimes, air entrainment (injection wells), or scaling (injection wells). Remediation system engineers constantly monitor the water level during injection. When a high water level set point is reached, a backwashing event is scheduled. The high water level set point ranges from 280 to 302 ft below ground surface in the injection wells. A second set point would be invoked if the water level was to rise to within 140 to 162 ft of ground surface, in which case all of the extraction and injection wells automatically shut down. These set points provide a factor of safety for injection well operation, independent of specific capacity. WSTF continues to inject all water extracted and treated by the PFTS (with the exception of backwash water discharged to grade). This is the primary measure of injection well effectiveness.

Backwashing is used at the injection wells to break up and/or dislodge these blockages. This is accomplished by taking the well offline and backwashing with the dedicated pump installed in the well. Backwashing requires a day or less to perform per well and typically results in only short-term benefits. Backwashing addresses only the area in the wellbore immediately adjacent to the pump intake; however, it has shown to be an effective means of maintaining well capacity in between more comprehensive well rehabilitation events. Backwashing, or over-pumping, at the extraction wells has not been necessary because clogging of the aquifer around the extraction wells has not been detected. This technique may be utilized at extraction wells in the future to alleviate clogging, if necessary.

When well backwashing maintenance ceases to be effective in restoring production capabilities due to more widespread or intense aquifer clogging, well rehabilitation may be required. Well rehabilitation involves removing the existing piping, equipment, and pumps from an affected well so that specialized equipment can be utilized to impact the aquifer throughout the entire screened section of the well. This more intense maintenance typically requires several days to weeks to perform and utilizes a specialized set of rehabilitation equipment supplied and operated by subcontractors. The last comprehensive rehabilitation of the injection wells was in 2012. NASA completed the rehabilitation of wells PFI-2, PFI-3, and PFI-4, at that time. NASA does not anticipate the need to abandon and replace any extraction or injection wells. However, should that become necessary, NASA will submit a work plan to NMED for approval.

6.3 MPITS Infiltration Basin Maintenance

Major scheduled maintenance is not required at the MPITS infiltration basin. Visual inspection of sediment accumulation, slope stability, and overall basin condition is conducted on a monthly basis. Trash and debris are removed, and periodic weed control is performed when required. Solid removal and scarification may be conducted if ponding reaches unacceptable levels.

6.4 Remediation System Groundwater Monitoring

To ensure adequate treatment of contaminated groundwater as specified in this Plan and DP-1255 (NMED, 2017), groundwater is sampled at various points in the PFTS and MPITS and analyzed for appropriate COCs. The overall performance of the systems is monitored by collecting and analyzing groundwater samples from the remediation system influent and effluent, PFE wells, and MPE wells.

6.4.1 Remediation System Influent and Effluent

The PFTS and MPITS are equipped with sampling ports to facilitate collection of groundwater samples at various points in the treatment processes. At both systems, influent sampling ports (B650-INF-1 and B655-INF-1, respectively) are located on the influent piping immediately upstream of treatment system components to monitor influent characteristics. Effluent sampling ports (B650-EFF-1 and B655-EFF-2, respectively) are located immediately downstream of the UV reactors to monitor effluent characteristics. These sampling ports are located directly on the process piping and consist of stainless-steel manual valves with stainless steel discharge tubing. Remediation system influent and effluent are sampled monthly for the analysis of NDMA and VOC by the most appropriate analytical method as described in the Groundwater Monitoring Plan (GMP; NASA, 2022b).

6.4.2 Remediation System Extraction Wells

Individual extraction wells are also equipped with sampling ports, which are constructed in a manner similar to the influent and effluent ports. Extraction well sampling ports are installed on the process piping in the PFE well vault or MPE well housing downstream of the wellhead. PFE and MPE wells are sampled at least quarterly for analysis of NDMA and VOC by the most appropriate analytical method as described in the GMP (NASA, 2022b). More frequent sampling may be performed during periods of system reconfiguration, troubleshooting, or other testing to monitor system performance and ensure adequate treatment of contaminated groundwater.

6.5 Related Groundwater Monitoring

Groundwater monitoring is also performed outside the PFTS and MPITS as part of NASA's comprehensive groundwater monitoring program. This sampling supports remediation system monitoring and evaluation. Groundwater monitoring is directed by the GMP, which identifies the groundwater monitoring wells, the frequency of sampling, and the analyses to be performed.

6.5.1 Groundwater Monitoring Wells

Groundwater monitoring wells used to determine the effectiveness of the PFTS and MPITS are described in detail in the GMP (NASA, 2022b). Plume Front and sentinel monitoring wells/zones are sampled at varying frequencies depending on their location in the plume, proximity to the PFTS, and intended use in the groundwater monitoring and remediation program. Most MPCA monitoring wells/zones are sampled at least semi-annually in accordance with the GMP (NASA, 2022b). As with PFE and MPE wells, more frequent sampling may be performed during periods of system reconfiguration, troubleshooting, or other testing to monitor system performance and ensure adequate groundwater treatment. At a minimum, groundwater monitoring wells used for PFTS and MPITS monitoring are sampled for analysis of NDMA and VOC by the most appropriate analytical method as described in the GMP (NASA, 2022b).

6.5.2 Groundwater Elevations

Groundwater elevations measured at monitoring wells and piezometers provide information required to evaluate the potentiometric surface, contaminant plume geometry, and groundwater model calibration. Groundwater elevations collected from monitoring wells at the westernmost edge of the monitoring well network also provide information that is used to evaluate the potential impact of regional aquifer pumping that may affect WSTF groundwater contaminant plume migration. At a minimum, groundwater elevations are measured each time a monitoring well is sampled. Additional measurements are collected as required to ensure adequate groundwater elevation data are available to support ongoing remediation system monitoring and performance evaluations.

The potentiometric surface map is used to interpret the effects of remediation system pumping on the Plume Front alluvial aquifer and the localized MPCA fractured rock aquifer. Individual extraction well drawdown and radii of influence are evaluated when the remediation system operational configuration allows for the collection of the data required to perform this analysis.

In general, performance will be evaluated as recommended in Environmental Protection Agency (EPA) guidance stressing “multiple lines of evidence” (EPA, 2002, 2008). A summary of plume capture evaluation exercises is provided in routine Periodic Monitoring Reports (PMR) as specified in Section 8.0. A more detailed evaluation of plume capture is provided in the comprehensive PMR, submitted annually to the NMED Hazardous Waste Bureau (HWB). Additional information related to the collection and use of groundwater elevations for evaluating remediation system performance is provided in the GMP (NASA, 2022b).

7.0 Remediation System Performance Evaluation

Remediation system performance is evaluated on a regular basis to assess whether adjustments to operational parameters and configurations are warranted to maintain or improve system operation.

7.1 Interim Measures Treatment System Goals

The goal of the PFTS is the stabilization of contaminant plume migration and COC mass reduction. Numerical flow and transport modeling extrapolated for over 40 years indicate that further migration of the plume can be arrested. Due to the anticipated duration of this corrective action, NASA has not yet formulated a specific exit strategy. Future progress will assist in the formulation of an effective strategy based on contemporary operational data.

The current primary objective of the MPITS is to intercept and treat contaminated groundwater moving from the source areas in the WSTF industrial area towards the Plume Front area, effectively cutting off the continued supply of contaminated groundwater to the Plume Front. Data from MPITS operation thus far indicates that a hydraulic sink has been created in the area near the MPITS extraction wells. This is evident by measured water level elevations downgradient of the extraction wells that have declined up to 30 ft since MPITS operation began. The presence of this hydraulic sink is favorable evidence that the MPITS is intercepting and treating contaminated groundwater at the MPCA. The MPITS is also used to treat and dispose of IDW generated during well sampling and testing activities.

7.2 Definition of Capture Zone

NASA continues to use groundwater modeling and particle tracking simulations to evaluate the PFTS capture zone. The three-dimensional target capture zone for the COCs that drive the Plume Front health risk assessment has historically been defined by the location of the TCE plume, which is the most extensive groundwater contaminant at WSTF. The current capture zone is defined as the furthest extent of the TCE and NDMA groundwater contaminant plumes. The extent of each plume is defined by the iso-concentration line that corresponds to the cleanup up level for each contaminant.

Over time, the dimensions and extent of the plume will change due to PFTS operation and changes in the groundwater gradient caused by off-site pumping. As the plume evolves, the target capture zone may be adjusted to prevent increases in risk to human health and the environment. As part of this process, ongoing analyses and potentiometric surface evaluations are performed to maintain current estimates of plume position, contaminant mass, and rates of removal.

7.3 Remediation System Effectiveness

PFTS and MPITS effectiveness is evaluated by comparing the results of effluent sampling and analysis described in Section 6.3, to the DP-1255 treatment standards in [Table 2.1](#). Fundamentally, the PFTS is considered effective if effluent concentrations meet discharge requirements and a plume capture evaluation indicates continued stability of the contaminant plume. The MPITS is considered effective if effluent concentrations meet treatment standards.

In addition to direct comparisons of analytical data to treatment standards, contaminant mass removal is estimated by comparing average influent and effluent concentrations for select COCs over time. Average concentrations in the influent and effluent will be combined with the measured volume of treated groundwater to estimate mass removal during a specific time interval. Although not a specific measurement of remediation system effectiveness, concentrations of COCs in groundwater samples collected from individual extraction wells and system influent are also periodically evaluated as an indicator of plume dynamics.

Several techniques are utilized to determine the effects of the operation of the remediation systems on the aquifer and contaminant plume. These techniques include a comprehensive evaluation of groundwater elevations through the use of potentiometric surface maps, a thorough assessment of groundwater chemical analytical data using time-concentration (T-C) plots and plume iso-concentration maps, the preparation and interpretation of a numerical groundwater model, and where practical, the evaluation of tracer test results. These tools are described in the sections below.

7.3.1 Potentiometric Surface Map

Measured groundwater depths are converted to piezometric elevations and plotted on a base map for the purpose of evaluating the effect of extraction wells on local groundwater flow paths. Piezometric elevations are determined for selected PFTS and MPITS groundwater monitoring wells by manually measuring the water level in conventional monitoring wells, calculating the piezometric elevation of target monitoring zones within Westbay^{®7} multiport wells based on the groundwater formation pressures measured at those zones, and obtaining groundwater depth data from pressure transducers installed within Water FLUTE[™] multiport wells. Groundwater elevations from Westbay and Water FLUTE wells are calculated using pressure data from the uppermost sampling ports proximal to the water table using Westbay pressure profile equipment and pressure transducers. These operations are conducted in accordance with the site-specific procedural documentation previously identified.

The potentiometric surface map is hand contoured by a qualified geologist. Automated contouring software may also be used to help develop the map. The results of the automated method are analyzed and modified or replaced by hand contouring if appropriate. The method used to produce the potentiometric surface is identified on the potentiometric surface map.

7.3.2 Time-Concentration Plots

Groundwater analytical data are presented as T-C plots for targeted groundwater monitoring wells or zones in the Plume Front area or MPCA. Historical analytical data used to populate the time-concentration plots are available through the WSTF groundwater analytical database, generally included

⁷ Westbay is a registered trademark of Nova Metrix Ground Monitoring (Canada) Ltd.

with each PMR. The following guidelines and considerations will be observed during the construction of T-C plots:

- Groundwater monitoring wells used for the development of T-C plots are designed in accordance with the applicable EPA/NMED point source monitoring guidance.
- T-C plots for the monitoring wells use each sampling dataset collected following installation of the well through the most recent available data.
- Analytical data are typically evaluated for hazardous constituents regulated under DP-1255.
- The selection protocol for analytical data includes using the highest concentration for qualifying samples collected during a sampling event at each well. Analytical results for use in a T-C plot are selected giving priority to analytical methods with greater accuracy and consider any qualified data.
- Non-detect results are reported at one half of the method detection limit concentration and plotted with a different symbol than detections for plume evaluation functionality, a visualization not intended for risk assessment or statistics. Non-detects in the latter context would be reported as less than limit of detection.

Due to changes in the off-site laboratory utilized to analyze groundwater samples, method detection limits for some analytes may change over reporting periods. Some of the subtle fluctuations in T-C plots may be the result of changing analytical technology. Other trends in contaminant concentrations may be identified as irregular responses to WSTF operations. Trends or patterns in the data will meet the general criteria that: several T-C plots (using data from several sampling events) supported the trend; the change in concentration is significant (typically an order of magnitude); and several contaminants within the location responded with similar trends. Irregularities in T-C plots that are not identified as responses to operations typically require additional data points and a greater change between recent concentrations and historical data.

7.3.3 Plume Iso-concentration Maps

Iso-concentration maps for contaminants of concern are primarily developed manually but may also use automated contouring software with the most recent analytical data available for each well. Automated contouring methods are not used for maps generated for the MPCA. Hand drawn contour maps are provided for the MPCA to allow for technical interpretation of hydrogeological features. Consideration of hydrogeological conditions, such as differing hydrostratigraphic units or significant structural features that cause the juxtaposition of variable hydraulic conductivities, may provide a more realistic representation of the contaminant plume.

Guidelines recommended for the selection and presentations of analytical data are as follows:

- The analytical data from MPCA monitoring wells are reviewed for the analytes regulated by DP-1255 (NMED, 2017). NDMA data are evaluated at the nanograms per liter (ng/L) concentration level based on its toxicity and importance relative to health risk evaluation. The remaining contaminants will be evaluated at the microgram per liter ($\mu\text{g/L}$) concentration level.
- Data processed through the WSTF quality assurance (QA) system during each reporting period are utilized for contouring. Priority is given to analytical methods with greater accuracy, and flagged data points are considered individually. The selection protocol uses the highest concentration for qualifying samples.

- The most recent analytical results available are utilized for contouring (including any wells for which no analytical data were available during the reporting period).
- When duplicate samples or multiple sampling results are available for a specific monitoring well or sampling point, the maximum concentration is utilized in accordance with WSTF convention for contouring using the most conservative approach.
- For multiport monitoring wells, the maximum contaminant concentration from any sampling zone within the well is used in accordance with WSTF convention for contouring using the most conservative approach.
- For conventional well clusters or closely adjacent monitoring wells, the most recent maximum contaminant concentration for the well group is used in accordance with WSTF convention for contouring using the most conservative approach.
- Analytical data from extraction wells may be considered for the plume evaluation even though these wells are non-compliant for point source monitoring purposes due to the extended screened intervals. In general, data obtained from extraction wells are utilized for engineering purposes only.
- Automated and manually constructed maps utilize the same analytical data sets.
- Contaminant plume iso-concentration plots do not represent a single horizontal layer or horizon within the contaminant plume, but a cumulative representation of the maximum values recorded over the sampling period at all depths.

7.3.4 Groundwater Modeling

Groundwater modeling simulations comprise an essential component of presenting the conceptual model of the contaminant plume. Particle tracking analyses are conducted for NDMA and TCE to evaluate the ability of the PFTS to achieve its design objectives. Particle tracking is performed using MODPATH software in conjunction with the WSTF groundwater flow model.

Due to the complexity of fractured bedrock and the proximity between flow pathways, the flow model was not developed to support the design of the MPITS relative to optimizing remediation well placement and system flow rates. However, it can be utilized to obtain generalized information on the effect of the MPITS as it relates to the behavior of the conceptualized plume on a larger scale at WSTF. With respect to the MPCA and MPITS operation, the WSTF groundwater model is used primarily as a support tool that assists with understanding large-scale plume behavior and contaminant movement through the fractured bedrock aquifer using the equivalent porous media approach.

7.4 Activity and Changes at Sentinel Wells

Monitoring wells utilized as sentinel wells for evaluation of plume capture are described in the GMP (NASA, 2022b). As indicated in that plan, routine monitoring supports the evaluation of PFTS effectiveness. Anomalies detected at sentinel wells may trigger additional sampling for confirmation purposes. If contaminant increases are verified through multiple sampling events, then changes to PFTS operation or even additional extraction wells to arrest plume migration will be considered. Due to the slow rate of groundwater migration in the Plume Front area, any proposed action to address contaminant increases at sentinel wells will proceed after thorough consideration and consultation with NMED.

7.5 Plume Capture Evaluation Methodologies

A comprehensive plume capture evaluation is performed annually to determine if the remediation systems are achieving the overall objectives of plume stabilization and interception. An effective plume capture evaluation is based on the six steps described in “Systematic Approach for Evaluation of Capture Zones at Pump and Treat Systems” (EPA, 2008). These steps are:

- Review site data, site conceptual model, and remedy objectives.
- Define site-specific Target Capture Zone(s).
- Interpret water levels.
- Perform calculations and groundwater modeling.
- Evaluate concentration trends.
- Interpret actual capture based on steps 1-5, compare to Target Capture Zone(s), and assess uncertainties and data gaps.

The scope of the EPA document is limited to evaluating capture in porous media (PFTS) and not necessarily fractured rock (MPITS), but the methods and techniques described in the EPA guidance are applied towards the evaluation of the effectiveness of MPITS contaminant interception, where possible. Results of plume capture evaluations are provided in the comprehensive PMR described below.

8.0 Reporting

Information related to remediation system operation and monitoring is provided to NMED in the scheduled correspondence described below. The GMP provides the schedule for the submittal of these reports, along with more detailed descriptions (NASA, 2022b).

- Monthly Environmental Activity Report, which summarizes remediation system operation, maintenance, and significant activities.
- “Routine” PMR, which includes chemical analytical data that were processed through the WSTF QA system during the reporting period. These PMRs also include brief discussions of groundwater monitoring and remediation activities and summarize the results of groundwater and remediation system monitoring.
- Comprehensive PMR, which includes additional data and a more comprehensive evaluation of corrective measures. This PMR includes a complete evaluation of contaminant plume capture and detailed results of remediation system monitoring.

9.0 Schedule for Review and Revision of the Plan

The RSMP will be reviewed and revised annually. Annual revisions will be submitted to the HWB on or before August 1 and are not considered Permit modifications.

10.0 References

Adoption of 40 CFR Part 262, Environmental Improvement Board, 20.4.1.300 NMAC (12/1/18).

EPA. (2002, December). *Elements for Effective Management of Operating Pump and Treat Systems*. EPA/542/R-02/009.

NASA White Sands Test Facility

- EPA. (2008, January). *A Systematic Approach for Evaluation of Capture Zones at Pump and Treat System*. EPA/600/R-08/003.
- Hazardous Waste, Environmental Improvement Board, 20.4 NMAC (12-1-18).
- NASA Johnson Space Center White Sands Test Facility. (1999, January 20). *Plume-Front Stabilization Work Plan*. Las Cruces, NM.
- NASA Johnson Space Center White Sands Test Facility. (2002, May 16). *Plume-Front Stabilization Work Plan* (revised for May 2002). Las Cruces, NM.
- NASA Johnson Space Center White Sands Test Facility. (2004, March 3). *Plume-Front Treatment System Project Plan*. Las Cruces, NM.
- NASA Johnson Space Center White Sands Test Facility. (2006, November 13). *Plume Front Treatment System Project Plan* (revised for November 2006). Las Cruces, NM.
- NASA Johnson Space Center White Sands Test Facility. (2008, October 30). *Mid-plume Interception Treatment System Interim Measures Work Plan Monitoring Plan*. Las Cruces, NM.
- NASA Johnson Space Center White Sands Test Facility. (2010, June 8). *Plume Front Treatment System Monitoring Plan*. Las Cruces, NM.
- NASA Johnson Space Center White Sands Test Facility, (2012, July 31). *Remediation System Monitoring Plan Annual Update*. Las Cruces, NM.
- NASA Johnson Space Center White Sands Test Facility. (2019, April 26). *Targeted Mobile Remediation Process Pilot Test Work Plan*. Las Cruces, NM.
- NASA Johnson Space Center White Sands Test Facility. (2021, June 29). *NASA WSTF Remediation System Monitoring Plan Annual Update for 2021*. Las Cruces, NM.
- NASA Johnson Space Center White Sands Test Facility. (2022a, March 8). *NASA WSTF Targeted Mobile Remediation Process Pilot Test Report*. Las Cruces, NM.
- NASA Johnson Space Center White Sands Test Facility. (2022b, April 29). *NASA WSTF Groundwater Monitoring Plan Update for 2022*. Las Cruces, NM.
- NMED Hazardous Waste Bureau. (2009, November 3). *Hazardous Waste Permit No. NM8800019434* (modified December 2019). Santa Fe, NM.
- NMED Ground Water Quality Bureau. (2017, July 14). *Discharge Permit Renewal and Modification, DP-1255, NASA White Sands Testing Facility*. Santa Fe, NM.
- NMED Hazardous Waste Bureau. (2019, April 2). *Approval with Modification Targeted Mobile Remediation Process Pilot Test Work Plan*. Santa Fe, NM.
- NMED Hazardous Waste Bureau and Ground Water Quality Bureau. (2022, June). *Risk Assessment Guidance for Site Investigations and Remediation Volume I Soil Screening Guidance for Human Health Risk Assessments*. Santa Fe, NM.
- Solid Waste, Environmental Improvement Board, 20.4 NMAC (12-1-18).

Tables

Table 2.1 DP-1255 Discharge Standards¹

Contaminant	Standard
NDMA	4.91 ng/L
TCE	2.59 µg/L
PCE	40.3 µg/L
Chloroform	2.29 µg/L

¹ The discharge standard specified in DP-1255 is the lower of the cancer or noncancer tap water screening level provided in Table A-1 of the NMED Risk Assessment Guidance for Site Investigations and Remediation (NMED, 2022).

Table 3.1 PFTS Air Stripper Performance Specifications

Criteria	Specification	
Total Hydraulic Flow Rate	1,250 gpm	
Hydraulic Flow Rate per Air Stripper	625 gpm	
Maximum Run Time	24 hours per day	
	365 days per year	
Design Life	>15 years	
Air Temperature	Minimum	-13 °C
	Annual Average	17 °C
	Maximum	44 °C
Influent Water Temperature	15 to 20 °C	
Site Elevation	4,500 ft above mean sea levels (AMSL)	
Expected Influent Concentrations	TCE	130 µg/L
	PCE	4.2 µg/L
	Chloroform	<1 µg/L
Effluent Standards	See Table 2.1	

Table 3.2 PFTS UV System Performance Specifications

Criteria	Specification	
Total Hydraulic Flow Rate	200-3,000 gpm	
Maximum Run Time	24 hours per day 365 days per year	
Design Life	>15 years	
Maximum System Pressure	100 psig	
Maximum Pressure Drop	10 psig	
Site Elevation	4,500 ft AMSL	
Expected Influent Concentrations	NDMA	2,000 ng/L
Effluent Standards	NDMA	See Table 2.1

Table 3.3 MPITS Air Stripper Performance Specifications

Criteria	Specification	
Total Hydraulic Flow Rate	20-125 gpm	
Maximum Run Time	24 hours per day 365 days per year	
Design Life	>15 years	
Air Temperature	Minimum	-13 °C
	Annual Average	17 °C
	Maximum	44 °C
Influent Water Temperature	15 °C	
Site Elevation	4,500 ft AMSL	
Expected Influent Concentrations	TCE	140 µg/L
	PCE	6.4 µg/L
	Chloroform	<1 µg/L
Effluent Standards	See Table 2.1	

Table 3.4 MPITS UV System Performance Specifications

Criteria	Specification	
Total Hydraulic Flow Rate	20-125 gpm	
Minimum Flow Rate	20 gpm	
Maximum Run Time	24 hours per day 365 days per year	
Design Life	>15 years	
Maximum System Pressure	65 psig	
Maximum Pressure Drop	10 psig	
Site Elevation	4,500 ft AMSL	
Expected Influent Concentrations	NDMA	25,500 ng/L
Effluent Standards	NDMA	See Table 2.1

Figures

(SEE NEXT PAGE)

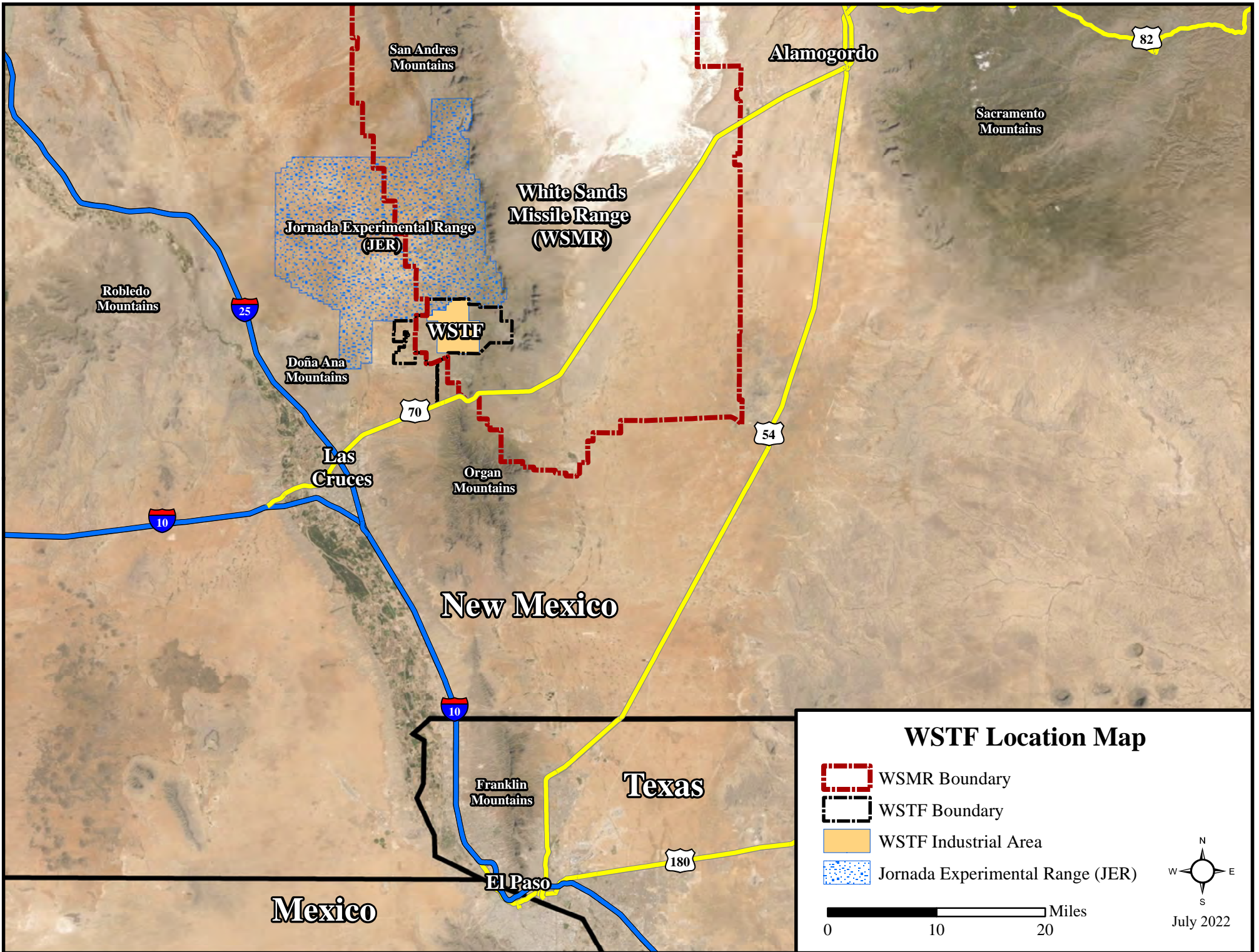

San Andres Mountains

Alamogordo

Sacramento Mountains

White Sands Missile Range (WSMR)

Jornada Experimental Range (JER)

Robledo Mountains

Doña Ana Mountains

WSTF

Las Cruces

Organ Mountains

New Mexico

Texas

Franklin Mountains

El Paso

Mexico

Figure 1.2 WSTF Conceptualized TCE and NDMA Plumes and WSTF Features

(SEE NEXT PAGE)

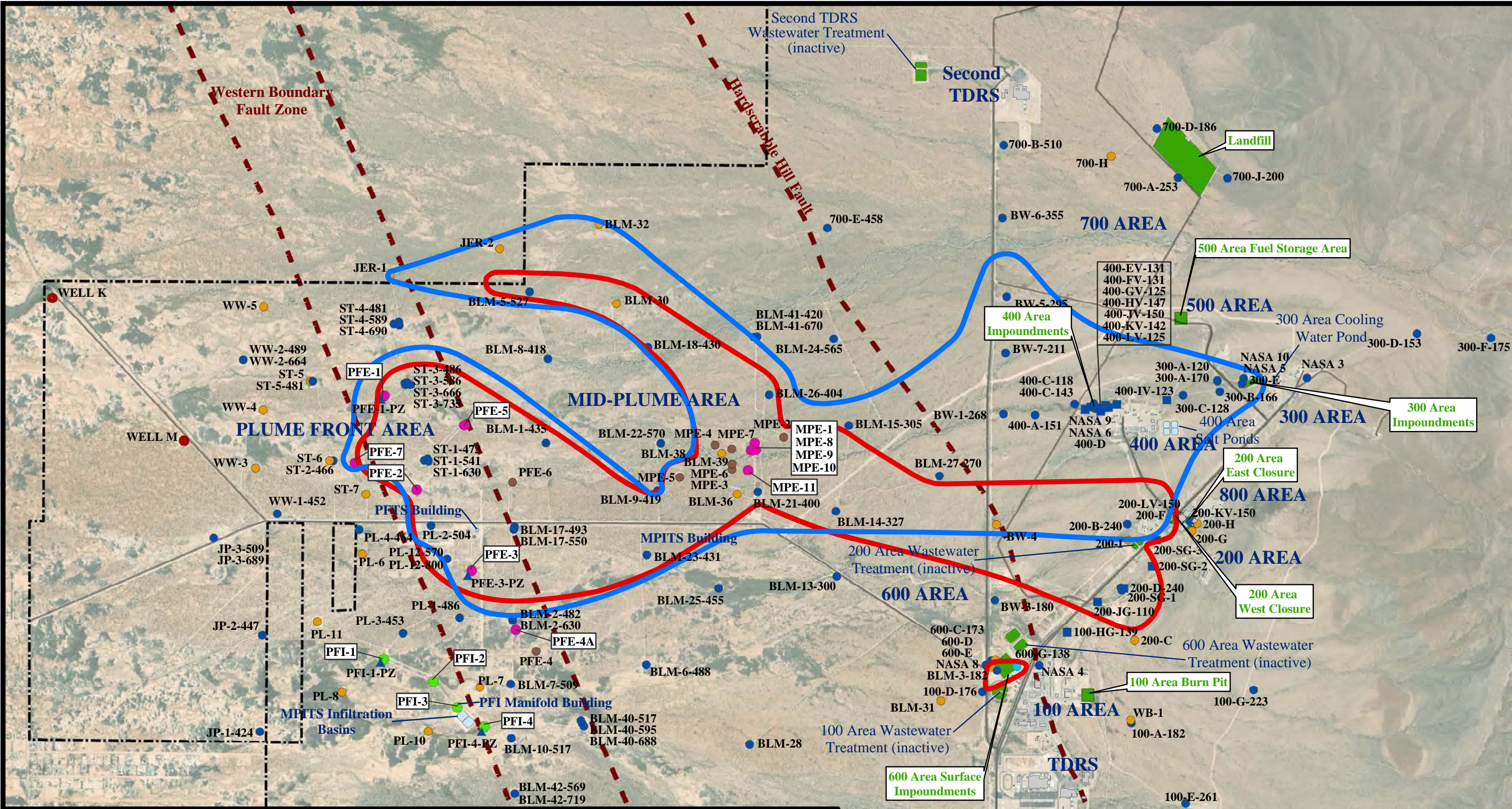

NASA-WSTF Site Features 2022

- | | | | |
|---------------------|--------------------|----------------------|-------------------------|
| ● Conventional Well | ● Injection Well | ▭ NASA-WSTF Boundary | — NDMA Extent (1.1 ppt) |
| ● Perched Well | ▲ Piezometer | ▭ Impoundment | — TCE Extent (4.9 ppb) |
| ● Multiport Well | ● Exploration Well | ▭ Building | |
| ■ MSVGM Well | ● Production Well | — Road | |
| ● Extraction Well | ■ RCRA Area | | |
- Note: NDMA and TCE extents represent second quarter 2022 data.
- 0 1,000 2,000 4,000 Feet



July 2022

Figure 3.1

General PFTS Layout

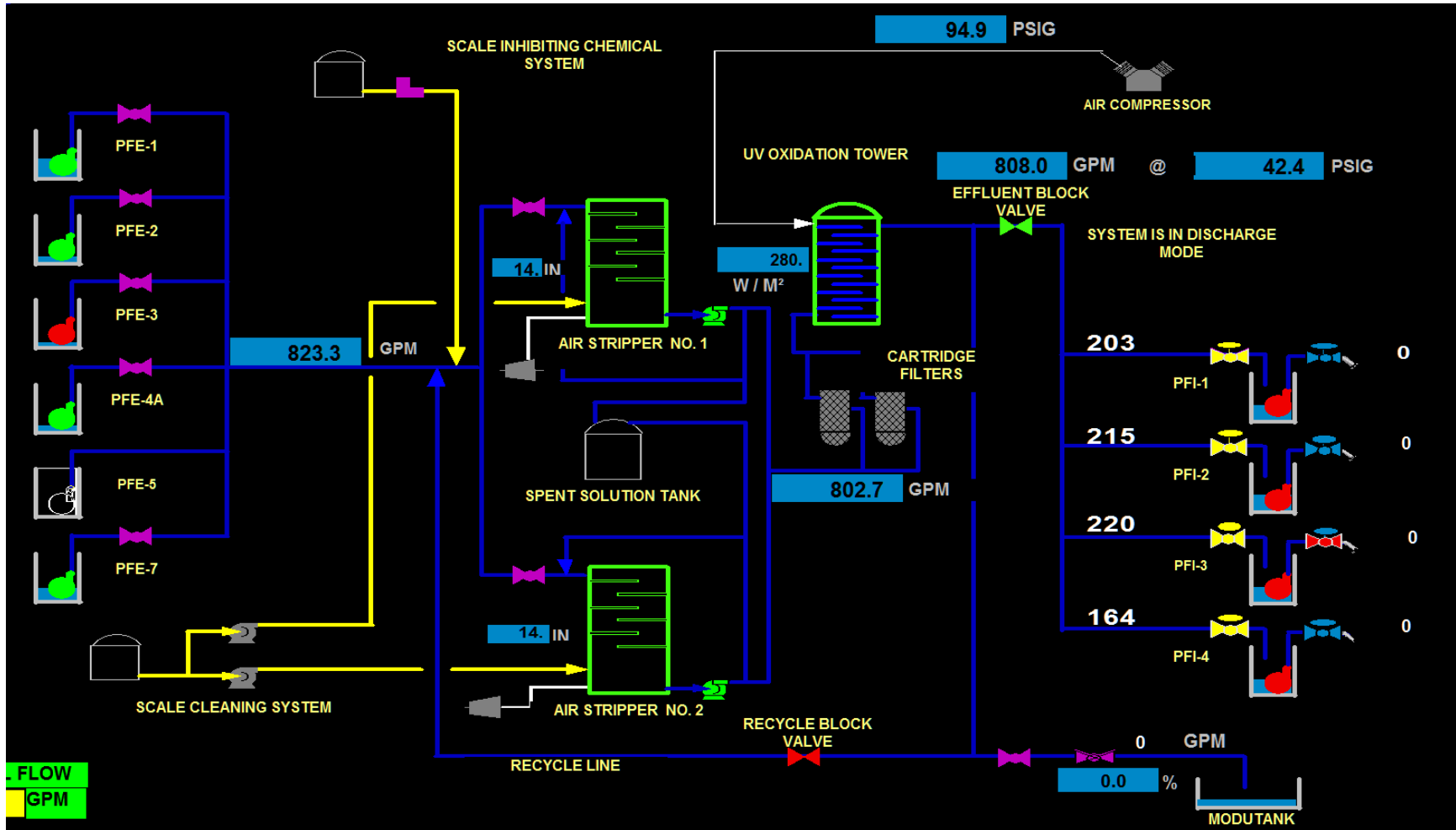

(SEE NEXT PAGE)

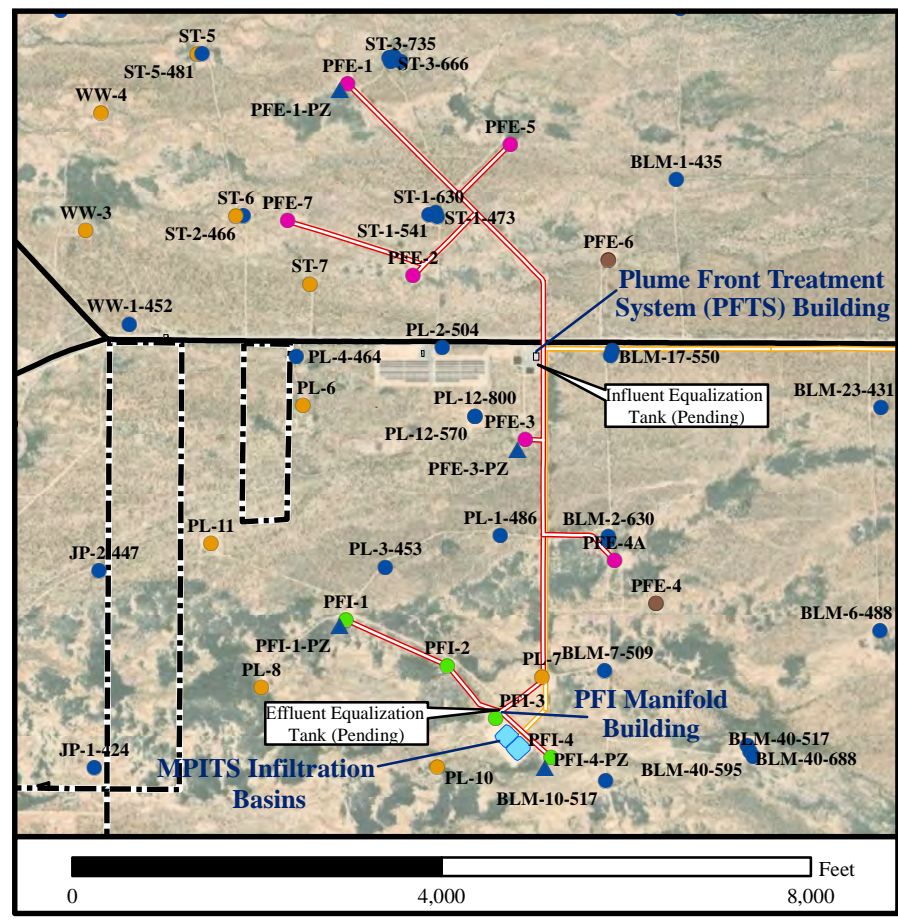
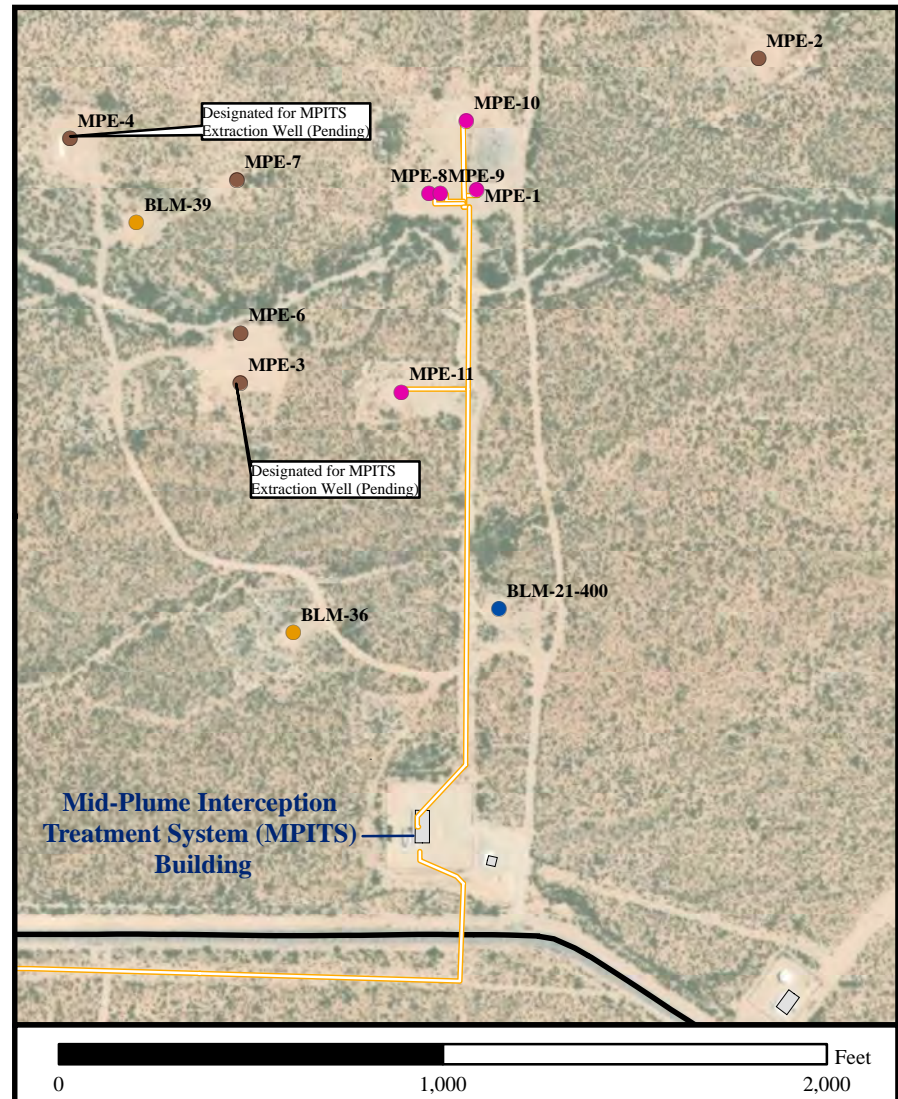
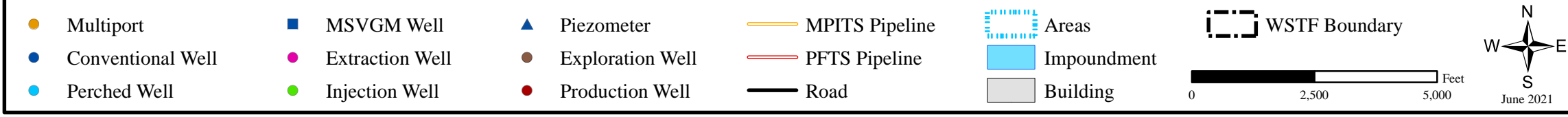
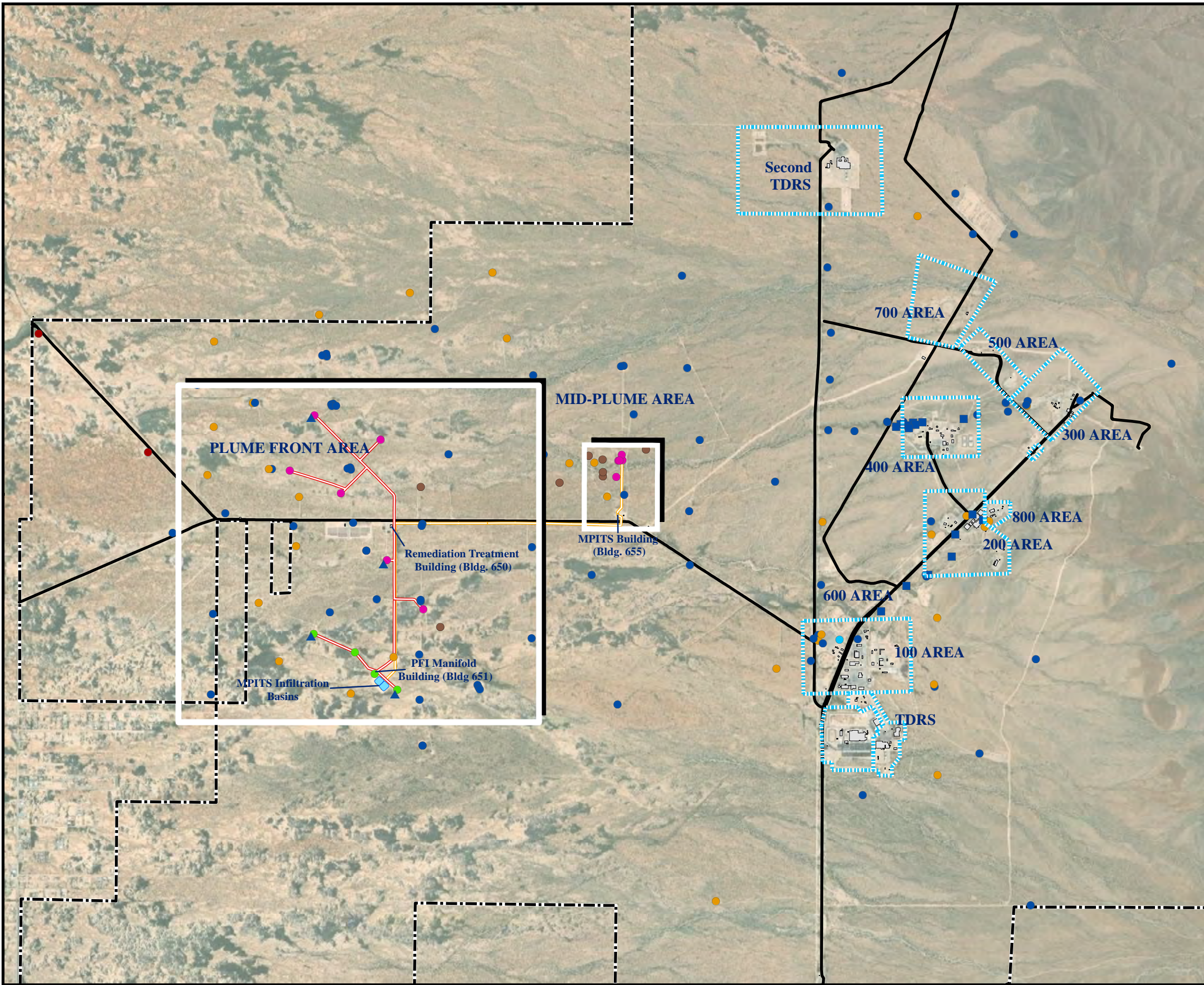
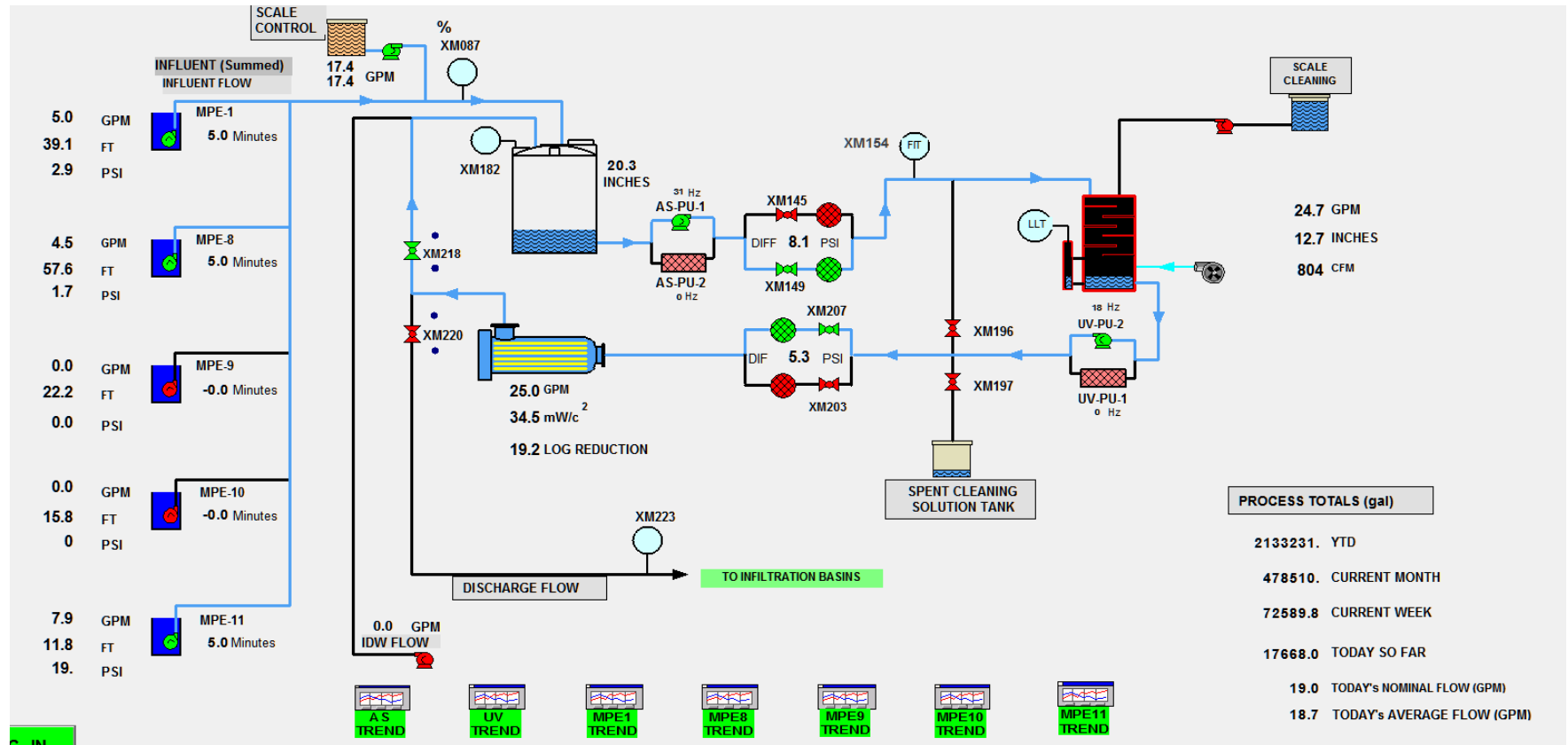

Figure 3.3

General MPITS Layout



Appendix A
Remediation System Well Completion Diagrams

WELL COMPLETION DIAGRAM

EXTRACTION WELL

Location ID: **MPE-1**

Site ID: **NASA-WSTF, Doña Ana County, NM**

Township and Range: **SE 1/4 NE 1/4 SE 1/4, Sec 33, T20S, R3E**
 Site Coordinates: **168825.02N 464184.53E**
 Elevation (Brass Cap): **1418.09 m AMSL**
 Elevation (Top of Casing): **1418.56 m AMSL**
 Drilling Contractor: **Stewart Brothers Drilling Company**
 Driller: **J. Aguilar**
 Total Depth of Borehole (bgs): **~560' (170.69 m)**
 Borehole Diameter: **Reamed 17 1/2" to 120'; 12 1/4" to 560'**
 Depth to Bedrock (bgs): **~250' (76.20 m)**
 Depth to Groundwater: **327.59' (99.85 m) TOC (~12/2006)**
 Total Depth Surface Casing (bgs): **120.00' (36.57 m)**
 Diameter and Type Surface Casing: **13 1/2" ID, 14" OD Steel**

Date(s) Well Installed: **7/9/99 - 7/10/99**
 Date(s) Well Developed: **7/14/99 - 8/6/99 (Initial)**
 Field Representative(s): **J. Pearson**
 Total Depth Well Casing (bgs): **522.72' (159.33 m)**
 Type of Casing: **316L Stainless Steel**
 Diameter Well Casing: **Nominal 6"**
 Casing Schedule: **5**
 Screened Zone (bgs): **362.46 - 512.70' (110.48 - 156.27 m)**
 Comments: **This well is located on a MPCA structure identified from shallow seismic data.**
bgs = below ground surface TOC = Top of Casing
AMSL = Above Mean Sea Level

Casing Explanation:		Annular Materials Explanation:	
Surface Casing Steel Surface Casing	Conventional End Cap Nominal 6" 316L Stainless Steel	Cement	1/8 Gravel
Conventional Casing Nominal 6" 316L Stainless Steel	Welded Steel Centralizers	Bentonite (Grout Well DF)	4/8 Sand
Conventional Screen Nominal 6" 316L Stainless Steel	Water Table	Bentonite Seal	6/9 Sand
0.020"-Slot Wire-Wrapped		10/20 Sand Bentonite Mix	8/12 Sand
		Slough	8/20 Sand
			10/20 Sand
			16/40 Sand
			20/40 Sand
			30/70 Sand

Feet/Meters

Well Descriptions
All depths listed are bgs (unless noted)

Annular/Borehole Descriptions
All depths listed are bgs

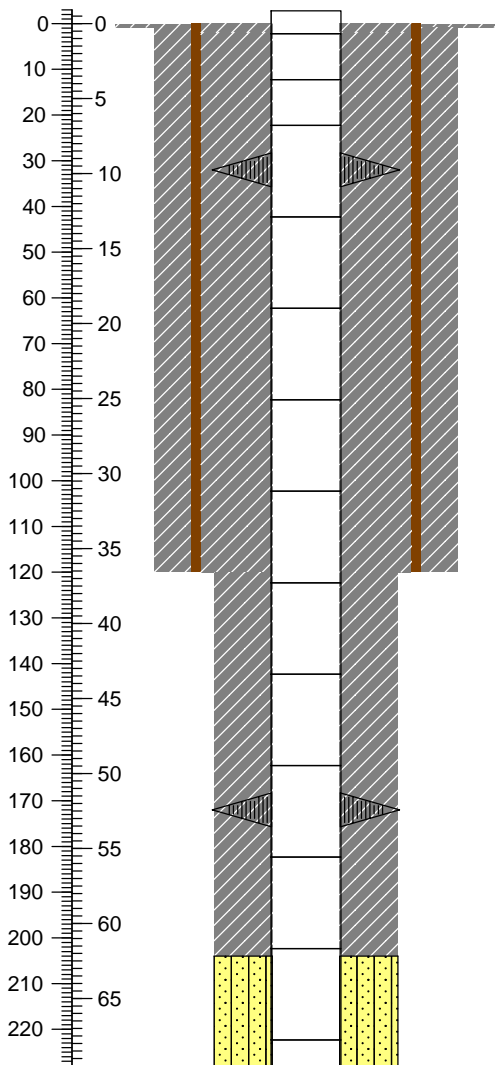

Conventional Well Stick-Up = ~2.8' (0.85 m)

The well was completed with a ~3' x ~3' cement pad, barrier posts, and a locking steel well cap surrounding the casing at ground surface.

Three steel centralizers welded to casing at ~32' (9.75 m)

14" OD Steel Surface Casing Depth = 120.00' (36.58 m)

Three steel centralizers welded to casing at ~172' (52.43 m)

Top of Cement Grout (Portland II Cement with 5% Bentonite) ~ 2' (0.61 m)

17 1/2" Borehole cemented to 120.00' (36.58 m)

Top of 10/20 Sand/Bentonite Mix = ~204' (62.18 m)

Casing Explanation:		Annular Materials Explanation:	
Surface Casing Steel Surface Casing	Conventional End Cap Nominal 6" 316L Stainless Steel	Cement	1/8 Gravel
Conventional Casing Nominal 6" 316L Stainless Steel	Welded Steel Centralizers	Bentonite (Grout Well DF)	4/8 Sand
Conventional Screen Nominal 6" 316L Stainless Steel 0.020"-Slot Wire-Wrapped	Water Table	Bentonite Seal	6/9 Sand
		10/20 Sand Bentonite Mix	8/12 Sand
		Slough	8/20 Sand
			10/20 Sand
			16/40 Sand
			20/40 Sand
			30/70 Sand

Feet/Meters	Well Descriptions All depths listed are bgs (unless noted)	Annular/Borehole Descriptions All depths listed are bgs
-------------	---	--

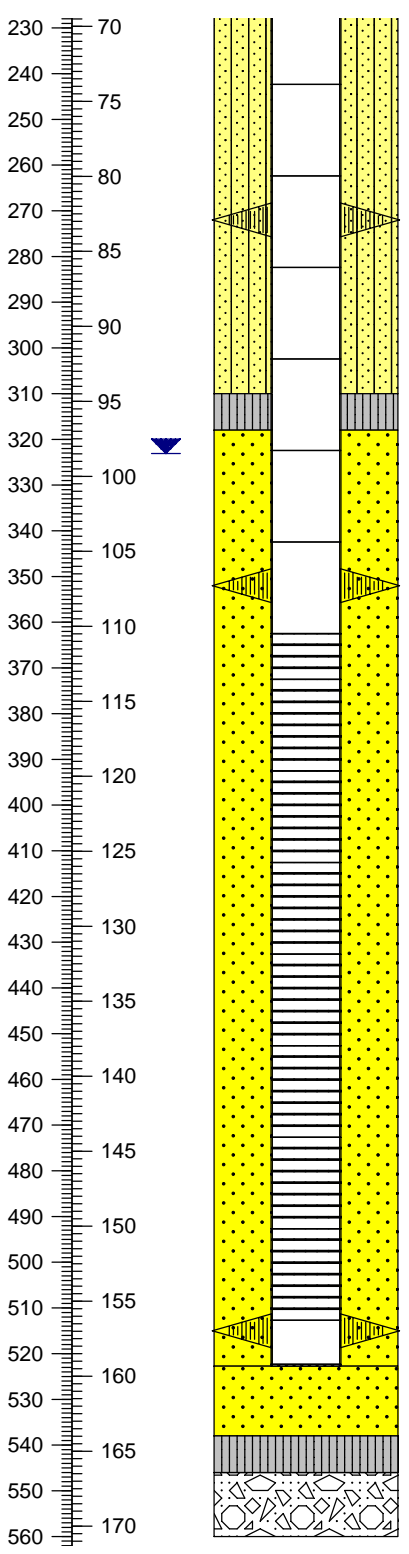

<p>Three steel centralizers welded to casing at ~ 272' (82.90 m)</p> <p>Water Table = 327.59' (99.85 m; TOC)</p> <p>Three steel centralizers welded to casing at ~352' (107.29 m)</p> <p>Top of (6" ID) 316L Schedule 5 Wire-Wrapped Stainless Steel 0.020"-Slot Screen (Extra Strength) = 362.46' (110.49 m)</p> <p>Bottom of (6" ID) 316L Schedule 5 Wire-Wrapped Stainless Steel 0.020"-Slot Screen (Extra Strength) = 512.70' (156.27 m)</p> <p>Three steel centralizers welded to casing at ~ 515' (156.97 m)</p> <p>(6" ID) 316L Schedule 5 Stainless Steel Casing TD = 522.72' (159.33 m)</p> <p>Sump consists of 10' blank riser and end cap</p>	<p>Volcanic Bedrock Depth = ~250.0' (76.20 m)</p> <p>Top of Upper Bentonite Seal = ~310' (94.49 m)</p> <p>Top of 10/20 Sand = ~318' (96.93 m)</p> <p>Top of Lower Bentonite Seal = ~538' (163.98 m)</p> <p>Top of Slough = ~546' (166.42 m)</p> <p>12 1/4" Borehole TD = ~560' (170.69 m)</p>
--	---

WELL COMPLETION DIAGRAM

EXTRACTION WELL

Location ID: **MPE-8**

Site ID: **NASA-WSTF, Doña Ana County, NM**

Township and Range: **SE 1/4 NE 1/4 SE 1/4 Sec 33, T20S, R3E**
 Site Coordinates: **168822.75 N 464152.59 E**
 Elevation (Ground Surface): **1417.62 m AMSL**
 Elevation (Top of Casing): **1418.54 m AMSL**
 Drilling Contractor: **Stewart Brothers Drilling Company**
 Driller: **L. Pasquale, L. P. Garcia, and W. Chamberlain**
 Total Depth of Borehole (bgs): **620.00' (189.98 m)**
 Borehole Diameter: **9 7/8" to 406' (123.75 m); 6 3/4" to 620' (188.98 m)**
 Depth to Bedrock (bgs): **~296' (90.22 m)**
 Depth to Groundwater: **322.47' (98.29 m) TOC (6/24/05)**
 Total Depth Surface Casing (bgs): **403.00' (122.83 m)**
 Diameter and Type Surface Casing: **6 7/8" ID, 7 5/8" OD Steel**

Date(s) Well Installed: **3/5/03-3/7/03**
 Date(s) Well Developed: **4/8/03 to 4/28/03**
 Field Representative(s): **M. Canavan, L. Hunnicutt-Mack, and M. Stepro**
 Total Depth Well Casing (bgs): **601.31' (183.28 m)**
 Type of Casing: **Flush-Threaded Carbon Steel**
 Diameter Well Casing: **5 7/8" ID, 6 5/8" OD**
 Casing Schedule: **14#J; 3120# Collapse**
 Screened Zone (bgs): **380.02-490.56' (wide); 490.56-600.50' (close)**
 Comments: **This well is located on a MPCA structure identified from shallow seismic data. Well produced >30 gpm during preliminary development. AMSL = Above Mean Sea Level bgs = below ground surface. TOC = Top of Casing**

	Casing Explanation:	Annular Materials Explanation:
Surface Casing 7 5/8" OD Steel	Cement	1/8 Gravel
Conventional Casing 5 7/8" ID Steel	Bentonite (Grout Well DF)	4/8 Sand
Conventional Screen 5 7/8" ID Steel (Wider Spaced-2 Slots/1') 1"-1 1/2"x1/4" Slot Size	Conventional End Cap 5 7/8" ID Steel	6/9 Sand
Conventional Screen 5 7/8" ID Steel (Closer Spaced-4 Slots/1') 1"-1 1/2"x1/4" Slot Size	Bentonite Seal	10/20 Sand
	Centralizers	6/9 Sand
	Water Table	8/12 Sand
		20/40 Sand
		8/20 Sand
	Slough	30/70 Sand

Feet/Meters

Well Descriptions	Annular/Borehole Descriptions
All depths listed are bgs (unless noted)	All depths listed are bgs

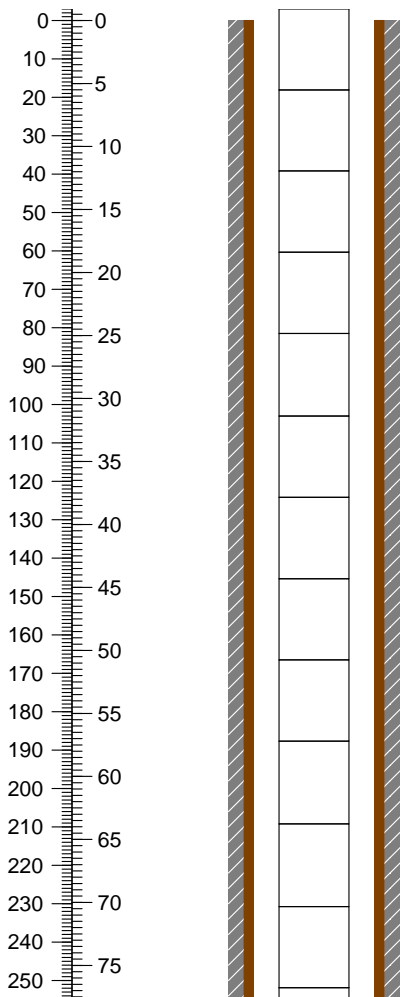

Conventional Casing Stick-Up = ~3.02' (0.92 m)
 Well has not been completed with ~3' x ~3' cement pad, barrier posts, or locking steel well cap surrounding the casing above ground surface to date (7/05)

No Centralizers Used

No Annular Materials Installed

Santa Fe Group Alluvium from surface to ~296' (90.22 m)

During hydrofracturing process, 16/30 sand was injected into formation to prop open any fractures created

Casing Explanation:		Annular Materials Explanation:			
Surface Casing 7 5/8" OD Steel	Cement	1/8 Gravel	4/8 Sand	10/20 Sand	
Conventional Casing 5 7/8" ID Steel	Bentonite (Grout Well DF)	6/9 Sand	8/12 Sand	16/40 Sand	
Conventional Screen 5 7/8" ID Steel (Wider Spaced-2 Slots/1')	Bentonite Seal	10/20 Sand/Bentonite Mix	8/20 Sand	20/40 Sand	
1"-1 1/2"x1/4" Slot Size	Conventional End Cap 5 7/8" ID Steel	Slough	30/70 Sand		
Conventional Screen 5 7/8" ID Steel (Closer Spaced-4 Slots/1')	Centralizers				
1"-1 1/2"x1/4" Slot Size	Water Table				

Feet/Meters	Well Descriptions All depths listed are bgs (unless noted)	Annular/Borehole Descriptions All depths listed are bgs
-------------	---	--

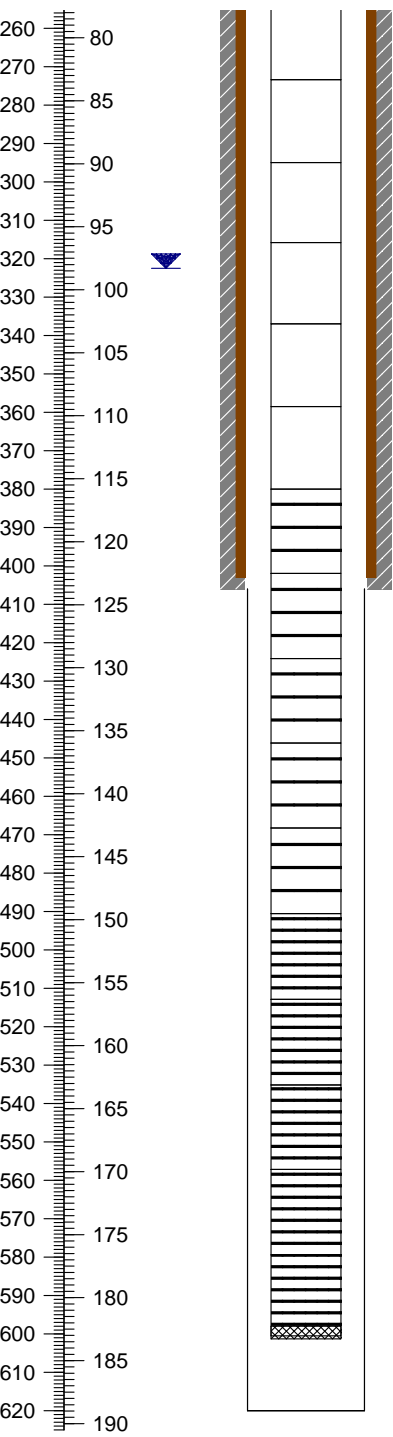

Water Table = 322.47' (98.29 m) (Measured 6/24/05; post-development)

Top of Widely Spaced Slotted Screen = 380.02' (115.83 m)
Slots = Vertical Machine-Cut 1" to 1 1/2" Long x 1/4" Wide
Widely Spaced Slots = 2 Slots per 1' Length

7 5/8" OD Steel Surface Casing Depth = 403.00' (122.8 m)

Top of Closely Spaced Slotted Screen = 490.56' (149.52 m)
Slots = Vertical Machine-Cut 1" to 1 1/2" Long x 1/4" Wide
Closely Spaced Slots = 4 Slots per 1' Length

Bottom of Closely Spaced Slots = 600.50' (183.03 m)
End cap was tapered and welded to screen
5 7/8" ID Steel Casing TD = 601.31' (183.28 m)

Rhyolite Bedrock Depth = ~296' (90.22 m)

9 7/8" Borehole Cemented to ~406' (123.75 m)
6 3/4" Borehole 406.00 - 620.00' (123.75 - 188.98 m)

Volcanic Rhyolite Tuff Bedrock Depth = ~455' (138.68 m)

Volcanic Flow Banded Rhyolite to Rhyolite Bedrock Depth = ~485' (147.83 m)

No Slough

6 3/4" Borehole TD = 620.00' (188.98 m)

WELL COMPLETION DIAGRAM

EXTRACTION WELL













Location ID: **MPE-9**

Site ID: **NASA-WSTF, Doña Ana County, NM**









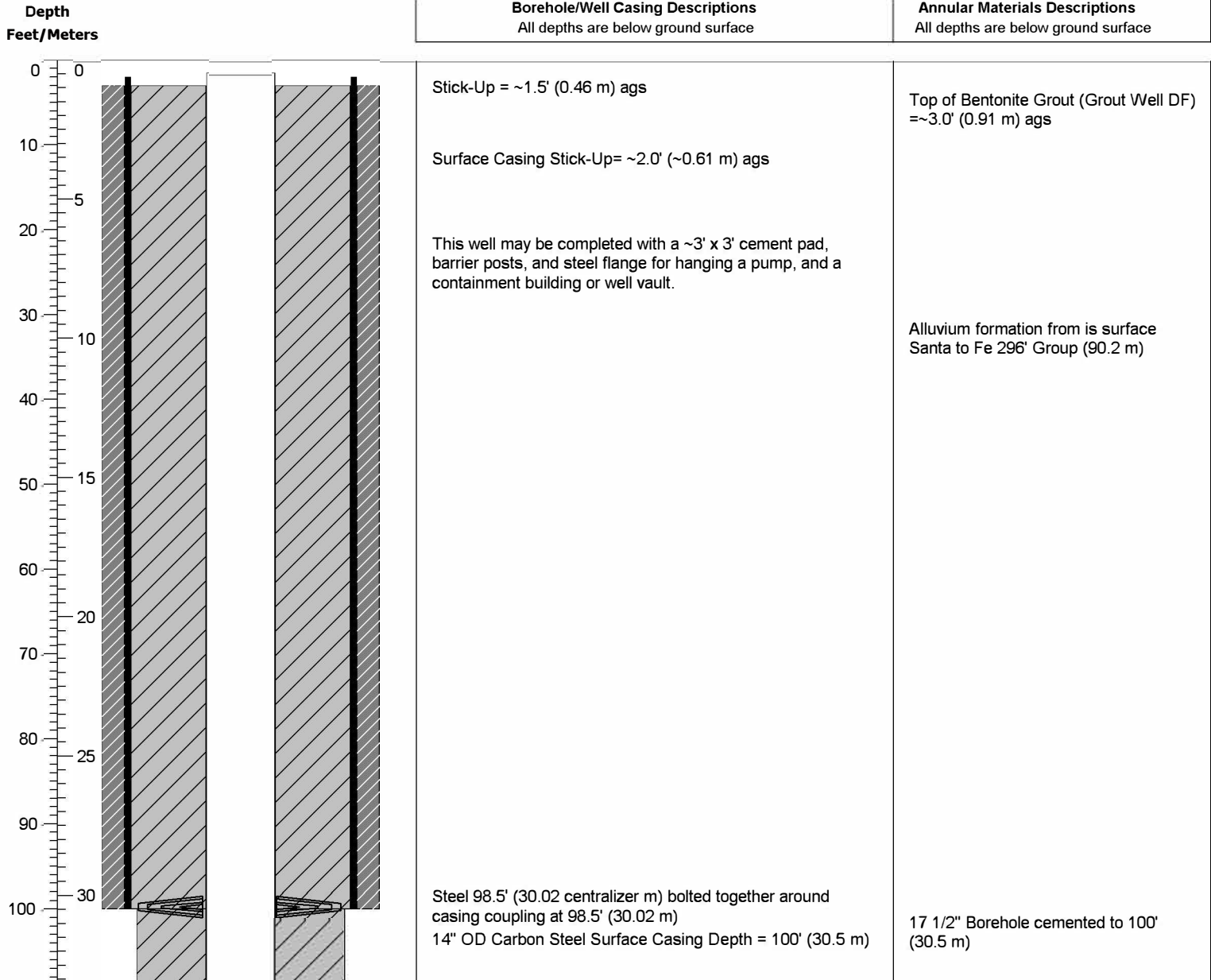



Township and Range: **SE 1/4 NE 1/4 SE 1/4 Sec 33 T20S R3E**
 NM State Plane Coordinates (NAD 83)(ft): **168822.88 N 464160.14 E (preliminary)**
 Elevation (Brass Cap): **1417.53 m (prelim. ground surface)**
 Elevation (Top of Casing): **~1.5' (0.5 m) ags (~1417.07 m)**
 Drilling Contractor: **Stewart Brothers Drilling Company**
 Driller: **G. Cardenas, D. Ward**
 Method of Drilling: **Mud Rotary**
 Total Depth of Borehole (bgs): **625' (190.5 m)**
 Borehole Diameter: **17 1/2" 0-100'; 12 1/4" 100-625'**
 Depth to Bedrock (bgs): **296' (90.2 m); Rhyolite**
 Depth to Groundwater: **322.9' (98.43 m) TOC (1/5/05)**
 Diameter and Type Surface Casing: **13 1/2" ID; 14" OD**

Dates Borehole Drilled: **6/30/04 to 7/26/04**
 Date(s) Well Installed: **7/28/04 to 8/4/04**
 Date(s) Well Developed: **8/4/04 bail; 8/6/04-8/23/04 pump**
 Field Representative(s): **G. Giles; L. Hunnicutt-Mack; J. Pearson**
 Total Depth Well Casing (bgs): **618.46' (188.51 m)**
 Type of Casing: **CertainTeed SDR 17 PVC**
 Diameter Well Casing: **6 1/4" ID; 6 9/10" OD**
 Screened Zone (bgs): **398.50- 598.50' (121.46 -182.42 m)**









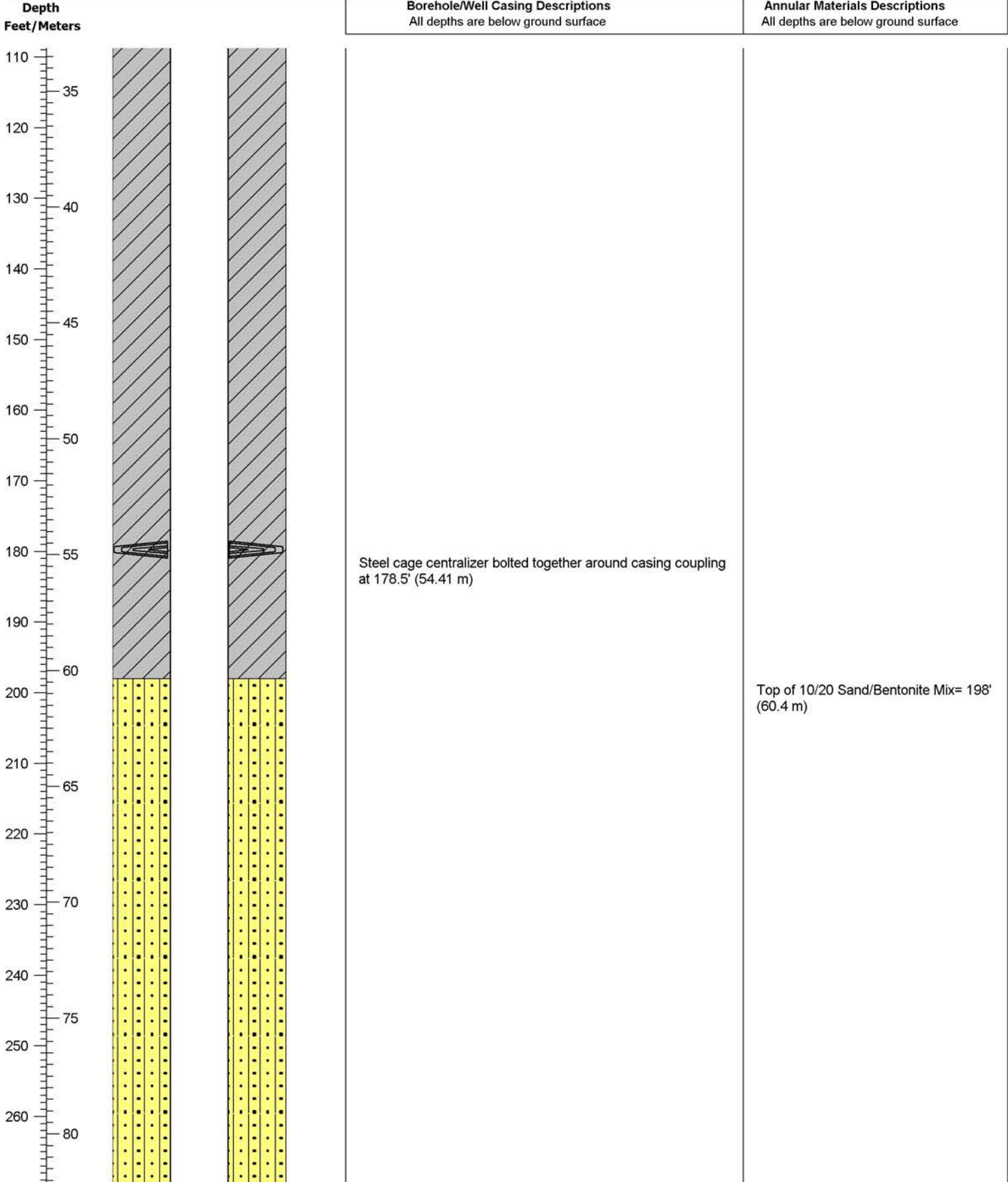



Comments:
 bgs = below ground surface TOC=Top of Casing
 ags= above ground surface
 ID = Inner Diameter OD= Outer Diameter

Casing Explanation	Annular Materials Explanation
 14" OD Carbon Steel  6 9/10" OD Certain Teed SOR 17 PVC  Well Screen  Certain Teed SOR 17 PVC 0.025"	 Neat Cement  Bentonite Grout  12/20 Sand Bentonite Mix  10/20 Filter Pack Sand  Slough
 Bolted Steel Centralizer  PVC End Cap  Water Table	









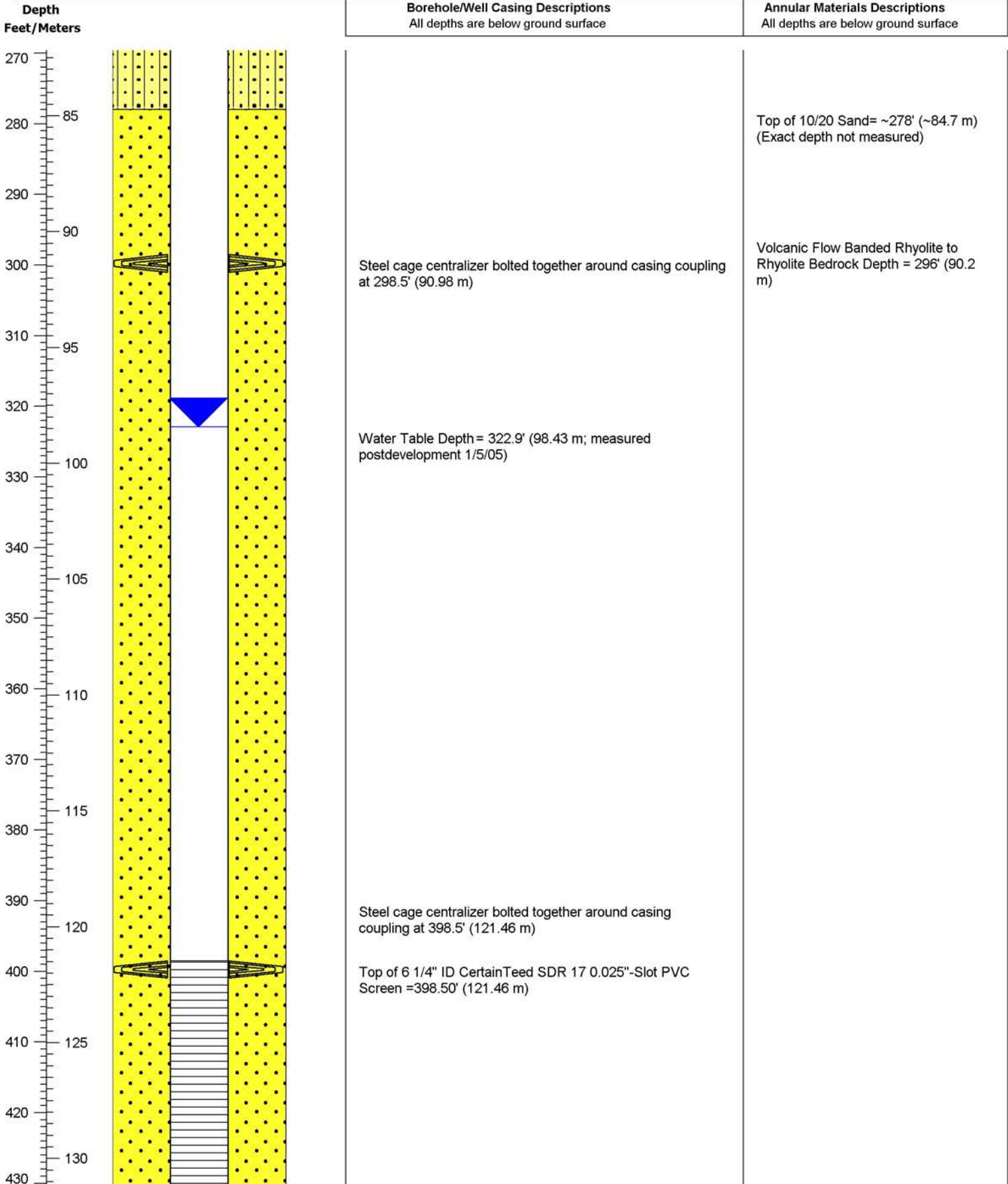



Casing Explanation		Annular Materials Explanation	
 Surface Casing 14" OD Carbon Steel	 Bolted Steel Centralizer	 Neat Cement	 10/20 Filter Pack Sand
 Completion Casing 6 9/10" OD Certain Teed SOR 17 PVC	 PVC End Cap	 Bentonite Grout	 Slough
 Well Screen	 Water Table	 12/20 Sand Bentonite Mix	
 Certain Teed SOR 17 PVC 0.025"			









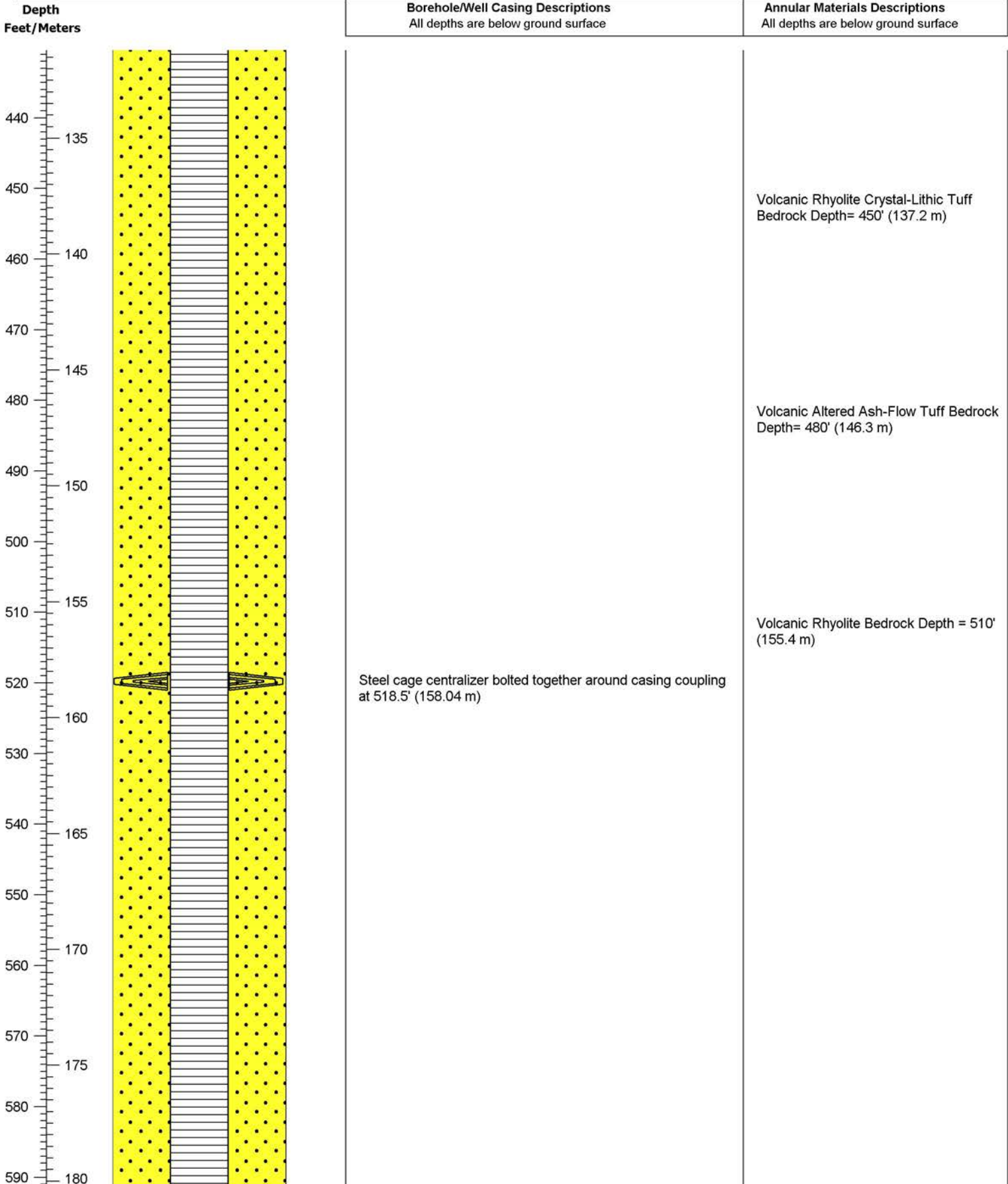





Casing Explanation		Annular Materials Explanation	
 Surface Casing 14" OD Carbon Steel	 Bolted Steel Centralizer	 Neat Cement	 10/20 Filter Pack Sand
 Completion Casing 6 9/10" OD Certain Teed SOR 17 PVC	 PVC End Cap	 Bentonite Grout	 Slough
 Well Screen	 Water Table	 12/20 Sand Bentonite Mix	
 Certain Teed SOR 17 PVC 0.025"			



Casing Explanation		Annular Materials Explanation	
 Surface Casing 14" OD Carbon Steel	 Bolted Steel Centralizer	 Neat Cement	 10/20 Filter Pack Sand
 Completion Casing 6 9/10" OD Certain Teed SOR 17 PVC	 PVC End Cap	 Bentonite Grout	 Slough
 Well Screen Certain Teed SOR 17 PVC 0.025"	 Water Table	 12/20 Sand Bentonite Mix	



Casing Explanation		Annular Materials Explanation	
 Surface Casing 14" OD Carbon Steel	 Bolted Steel Centralizer	 Neat Cement	 10/20 Filter Pack Sand
 Completion Casing 6 9/10" OD Certain Teed SOR 17 PVC	 PVC End Cap	 Bentonite Grout	 Slough
 Well Screen	 Water Table	 12/20 Sand Bentonite Mix	
 Certain Teed SOR 17 PVC 0.025"			

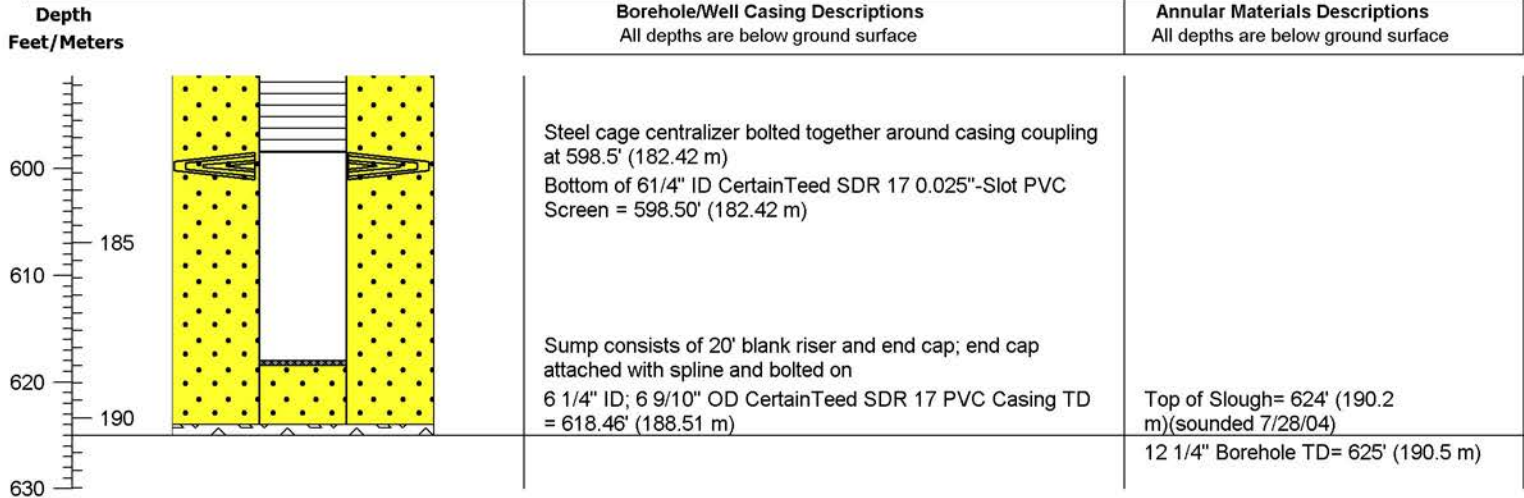



Location ID: **MPE-10 (second installation)**

Site ID: **NASA-WSTF, Doña Ana County, NM**

Township and Range: **NE 1/4 NE 1/4 SE 1/4 Sec. 33, T20S, R3E**
 NM State Plane Coordinates (NAD 83): **168871.20N 464177.77E (GPS)**
 Elevation (Ground Surface): **1417.37 m (GPS)**
 Elevation (Top of Casing): **1.04' (0.32 m) ags (~1417.69 m)**
 Drilling Contractor: **Stewart Brothers Drilling Company**
 Driller: **G. Cardenas**
 Total Depth of Borehole (bgs): **601.41' (183.31 m)**
 Borehole Diameter: **24" to 9.0"; 17 1/2" to 355'.0; 12 1/4" to 601.4'**
 Depth to Bedrock (bgs): **~235' (71.63 m); Rhyolite**
 Depth to Groundwater: **318.48' (97.07 m); TOC - Measured 2/15/2007**
 Total Depth Surface Casing (bgs): **355.00' (108.20 m) per geophysics**
 Diameter and Type Surface Casing: **13 1/2" ID, 14" OD Carbon Steel**

Date(s) Well Installed: **12/9 - 12/10/2006**
 Date(s) Well Developed: **12/11 - 12/22/2006**
 Field Representative(s): **G. Giles**
 Total Depth Well Casing (bgs): **597.40' (182.09 m)**
 Type of Casing: **CertainTeed SDR 17 PVC**
 Diameter Well Casing: **6" ID, 6 9/10" OD**
 Casing Schedule: **SDR 17**
 Screened Zone (bgs): **397.20' - 597.30' (121.07 - 182.06 m)**
 Comments: **This well is located on a MPCA structure identified from shallow seismic data.**
PVC casing installed on 12/9/2006
bgs = below ground surface. TOC = Top of Casing

<p>Surface Casing 14" OD Carbon Steel</p> <p>Conventional Casing 6" ID PVC</p> <p>Conventional Screen 6" ID; 6 9/10" OD PVC 0.032"</p>	<p>Casing Explanation:</p> <p> Conventional End Cap 6" ID PVC</p> <p> Bolted Steel Cage Centralizers</p> <p> Water Table</p>
---	--

Annular Materials Explanation:

 Cement

 Bentonite (Grout Well DF)

 8/12 Sand

Feet/Meters

Well Descriptions
All depths listed are bgs (unless noted)

Annular/Borehole Descriptions
All depths listed are bgs

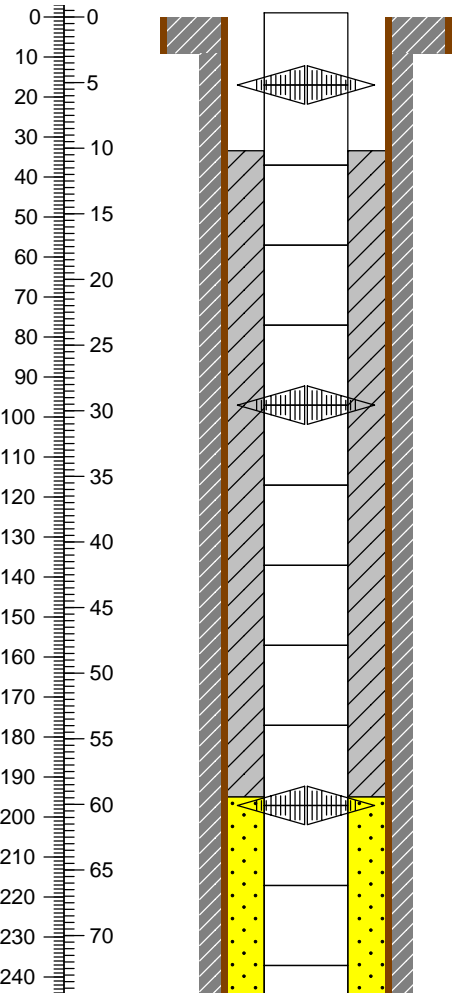

Conventional casing stick-up = 1.04' (0.32 m)

No surface casing stick-up

20" Steel Conductor pipe installed and cemented to 9.00' (2.74 m) bgs

Steel cage centralizer bolted together around casing coupling at 17.01' (5.19 m)

Steel cage centralizer bolted together around casing coupling at 97.05' (29.58 m)

Steel cage centralizer bolted together around casing coupling at 197.10' (60.08 m)

24" borehole cemented to 9.00' (2.74 m)

Top of bentonite grout (Grout Well DF) = 33.45' (10.20 m)

Top of 8/12 Sand = ~200' (60.96 m)

Volcanic bedrock (Rhyolite) depth = ~235' (71.63 m)

<p>Surface Casing 14" OD Carbon Steel</p> <p>Conventional Casing 6" ID PVC</p> <p>Conventional Screen 6" ID; 6 9/10" OD PVC 0.032"</p>	<p>Casing Explanation:</p> <p>Conventional End Cap 6" ID PVC</p> <p>Bolted Steel Cage Centralizers</p> <p>Water Table</p>		<p>Annular Materials Explanation:</p> <p>Cement</p> <p>Bentonite (Grout Well DF)</p> <p>8/12 Sand</p>
	<p>Feet/Meters</p>		<p>Well Descriptions All depths listed are bgs (unless noted)</p>

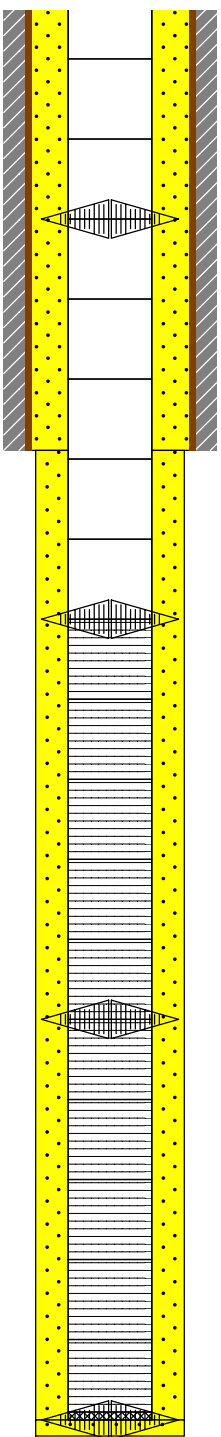
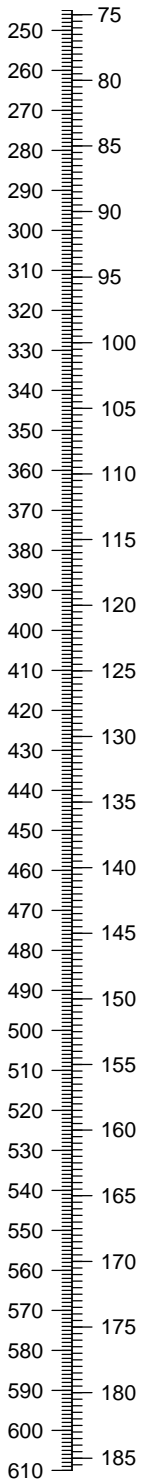

Steel cage centralizer bolted together around casing coupling at 297.15' (90.57 m)

Water Table = 318.48' (97.07 m); TOC - Measured 2/15/2007

14" OD steel surface casing depth = 355.00' (108.20 m)

Steel cage centralizer bolted together around casing coupling at 397.20' (121.07 m)

Top of 6" ID CertainTeed SDR 17 0.032"-Slot PVC Screen = 397.20' (121.07 m)

Steel cage centralizer bolted together around casing coupling at 497.25' (151.56 m)

Bottom of 6" ID CertainTeed SDR 17 0.032"-Slot PVC Screen = 597.30' (182.06 m)

Steel cage centralizer bolted together around casing at 597.40' (182.09 m)

6" ID; 6 9/10" OD CertainTeed SDR 17 PVC Casing TD = 597.40' (182.09 m)

Volcanic bedrock (Flow-Banded Rhyolite) depth ~ 250' (76.20 m)

17 1/2" borehole cemented to 355.00' (108.20 m)

12 1/4" borehole 355.00' - 601.41' (TD) (108.20 - 183.31 m)

Altered volcanic bedrock depth = ~400' (121.92 m)

Volcanic bedrock (Dacite) depth = ~460' (140.21 m)

Volcanic bedrock (Rhyolite) depth = ~515' (156.97 m)

12 1/4" borehole TD = 601.41' (183.31 m)

WELL COMPLETION DIAGRAM







EXTRACTION WELL

Location ID: **MPE-11 (2007 Reinstallation)**

Site ID: **NASA-WSTF, Doña Ana County, NM**

Township and Range: **NE 1/4 SE 1/4 SE 1/4 Sec. 33, T20S, R3E**
 NM State Plane Coordinates (NAD 83): **168690.40 N 464133.81 E**
 Elevation (Ground Surface): **1416.96 m (pending final survey)**
 Elevation (Top of Casing): **1.83' (0.56 m) ags (~1417.52 m)**
 Drilling Contractor: **Stewart Brothers Drilling Company**
 Driller: **G. Cardenas**
 Total Depth of Borehole (bgs): **609.00' (185.62 m)**
 Borehole Diameter: **24" to 10"; 17 1/2" to 423'; 12 1/4" to 609'**
 Depth to Bedrock (bgs): **~310' (94.48 m); Rhyolite**
 Depth to Groundwater: **494.80' (150.82 m) TOC (2/15/2007)**
 Total Depth Surface Casing (bgs): **420.00' (128.02 m) (Original)**
 Diameter and Type Surface Casing: **13.5" ID/14" OD Carbon Steel**

Date(s) Well Installed: **1/05, 1/07/07**
 Date(s) Well Developed: **Bail/Swab (1/8 - 6/07); Pump (1/10 - 16/07)**
 Field Representative(s): **M. Canavan, J. Pearson**
 Total Depth Well Casing (bgs): **600.00' (182.88 m)**
 Type of Casing: **CertainTeed PVC**
 Diameter Well Casing: **6" ID/ 6.9" OD**
 Casing Schedule: **SDR 17**
 Screened Zone (bgs): **499.75 - 599.96' (152.32 - 182.87 m)**
 Comments: **Original carbon steel well casing installed 10/15/04 was pulled, borehole reamed, and PVC well casing installed for potential use as Mid-Plume extraction well. bgs = below ground surface TOC = Top of Casing**

<p> Surface Casing Nominal 14" OD Carbon Steel</p> <p> Conventional Casing 6" ID PVC</p> <p> Conventional Screen 6" ID; 6.9" OD PVC 0.032"</p>	<p>Casing Explanation:</p> <p> Conventional End Cap 6" ID PVC</p> <p> Bolted Steel Cage Centralizers</p> <p> Water Table</p>
--	--

Annular Materials Explanation:

 Cement

 Bentonite (Grout Well DF)

 8/12 Sand

Feet/Meters

Well Descriptions
All depths listed are bgs (unless noted)

Annular/Borehole Descriptions
All depths listed are bgs

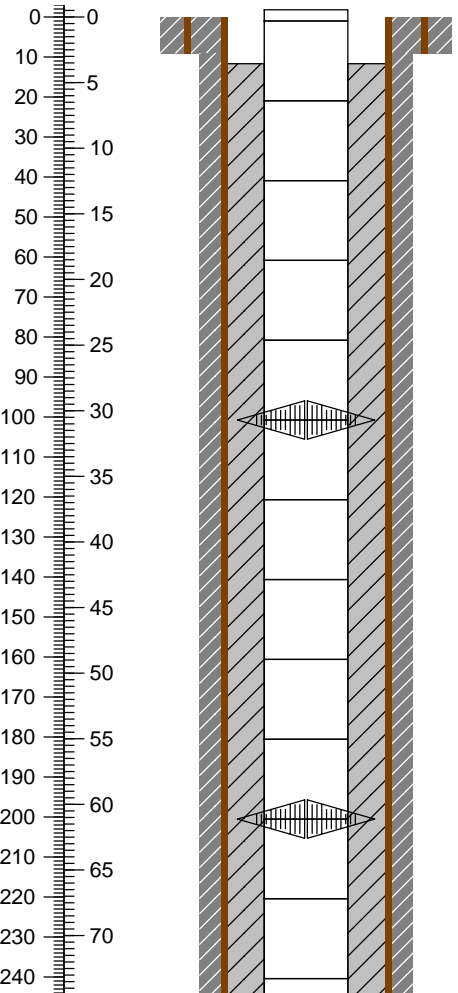

Conventional casing stick-up = 1.83' (0.56 m)

No surface casing stick-up

20" steel conductor pipe installed and cemented to 9.00' (2.74 m) bgs.

Steel cage centralizer bolted together around casing coupling at 100.75' (30.71 m)

Steel cage centralizer bolted together around casing coupling at 200.50' (61.11 m)

24" borehole cemented to 10.00' (3.05 m)

Top of bentonite grout (Grout Well DF) = 11.70' (3.57 m)

<p>Surface Casing Nominal 14" OD Carbon Steel</p> <p>Conventional Casing 6" ID PVC</p> <p>Conventional Screen 6" ID; 6.9" OD PVC 0.032"</p>	<p>Casing Explanation:</p> <p>Conventional End Cap 6" ID PVC</p> <p>Bolted Steel Cage Centralizers</p> <p>Water Table</p>		<p>Annular Materials Explanation:</p> <p>Cement</p> <p>Bentonite (Grout Well DF)</p> <p>8/12 Sand</p>
	<p>Conventional End Cap 6" ID PVC</p>		
	<p>Bolted Steel Cage Centralizers</p>		
	<p>Water Table</p>		

Feet/Meters	Well Descriptions All depths listed are bgs (unless noted)	Annular/Borehole Descriptions All depths listed are bgs
-------------	---	--

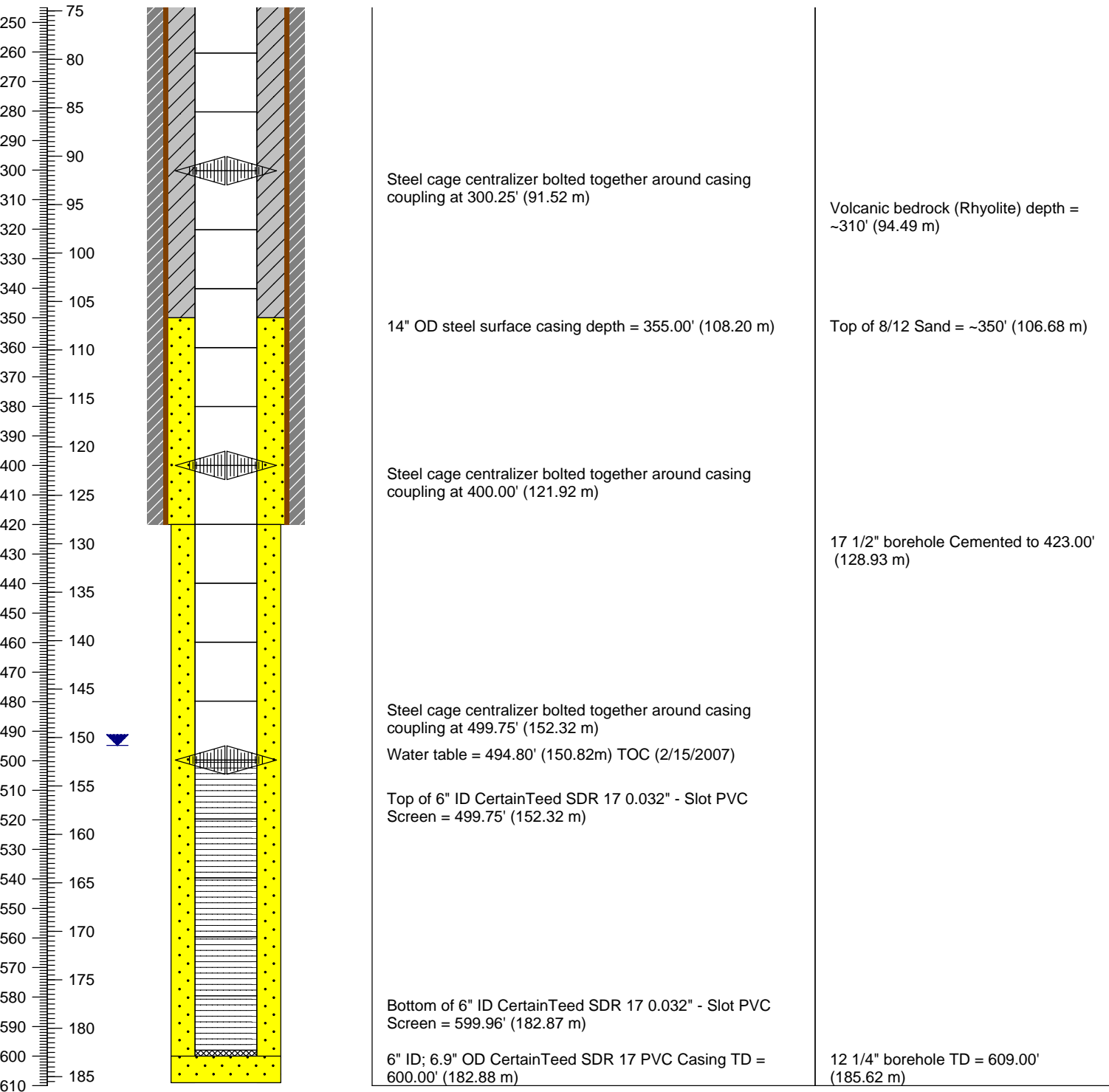

WELL COMPLETION DIAGRAM

EXTRACTION WELL

Location ID: **PFE-1**

Site ID: **NASA-WSTF, Doña Ana County, NM**

Township and Range: **SE 1/4 SE 1/4 NW 1/4 Sec 32, T20S, R3E**
 NM State Plane Coordinates (NAD 83): **169190.22 N 461691.33 E**
 Elevation (Ground Surface): **1368.50 (prelim)**
 Elevation (Top of Casing): **1368.84 m AMSL**
 Drilling Contractor: **Stewart Brothers Drilling Company**
 Driller: **J. Aguilar**
 Total Depth of Borehole (bgs): **788' (240.18 m)**
 Borehole Diameter: **17 1/2" 0 - 100' (reamed 26"); 17 1/2" 100 - 788'**
 Depth to Bedrock (bgs): **652' (198.73 m); Andesite**
 Depth to Groundwater: **422.63' (128.82 m) post development ~ (6/30/00)**
 Total Depth Surface Casing (bgs): **96' (29.26 m)**
 Diameter and Type Surface Casing: **19.5" ID; 20" OD Carbon Steel**

Date(s) Well Installed: **1/26/00 - 2/3/00**
 Date(s) Well Developed: **2/9 - 10/00 (bail); 6/12 - 29/00 (pump)**
 Field Representative(s): **M. Canavan, G. Giles, L. H-Mack, J. Kirby,**
 Total Depth Well Casing (bgs): **~768.4' (~234.21 m)**
 Type of Casing: **CertainTeed PVC**
 Diameter Well Casing: **9.31" min. ID; 10.75" OD**
 Casing Schedule: **SDR 17**
 Screened Zone (bgs): **~389 - 748.4' (~118.57 - 228.11 m)**
 Comments: **Well completed as an extraction well below grade in a cement vault.**
Final ground-surface elevation survey pending.
Field Reps. cont'd: J. Pearson, M. Rivera, R. Weaver

<p>Surface Casing 20" Carbon Steel</p> <p>Conventional Casing 10.75" OD CertainTeed PVC</p> <p>Conventional Screen 10.75" OD CertainTeed PVC 0.085"-Slot</p>	<p>Casing Explanation:</p> <p>Conventional End Cap 10.75" OD CertainTeed PVC</p> <p>Bolted Steel Cage Centralizers</p> <p>Water Table</p>	<p>Annular Materials Explanation:</p> <p>Cement</p> <p>Bentonite (Grout Well DF)</p> <p>Bentonite Seal</p> <p>4/8 Sand/Bentonite Mix</p> <p>Slough</p> <p>1/8 Gravel</p> <p>4/8 Sand</p> <p>6/9 Sand</p> <p>8/12 Sand</p> <p>8/20 Sand</p> <p>10/20 Sand</p> <p>16/40 Sand</p> <p>20/40 Sand</p> <p>30/70 Sand</p>
---	--	---

Feet/Meters

Well Descriptions
All depths listed are bgs (unless noted)

Annular/Borehole Descriptions
All depths listed are bgs

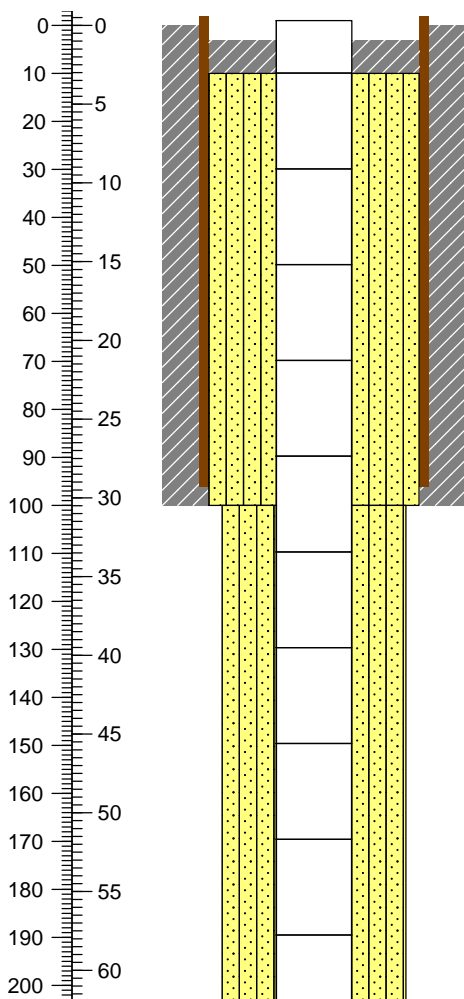

Stick-Up = ~1' (0.30 m) ags installed at installation. Casing was later cut below ground surface and well was completed within a cement well vault.

Surface Casing Stick-Up = 2' (0.61 m) ags at installation. Casing was later cut below ground surface and well was completed within a cement well vault.

NOTE: Individual casing joints not measured at installation. Average joint length approximately 19.95' based on measurements at PFE-4 installation.

20" OD Carbon Steel Surface Casing Depth = 96' (29.26 m)

Top of Cement Grout (Portland II) = ~3' (0.91 m)
 Top of 4/8 Sand/Bentonite Mix = 10' (3.05 m)

Santa Fe Group Alluvium from surface to 500' (152.40 m)

17 1/2" (reamed 26") borehole cemented to 100' (30.48 m)

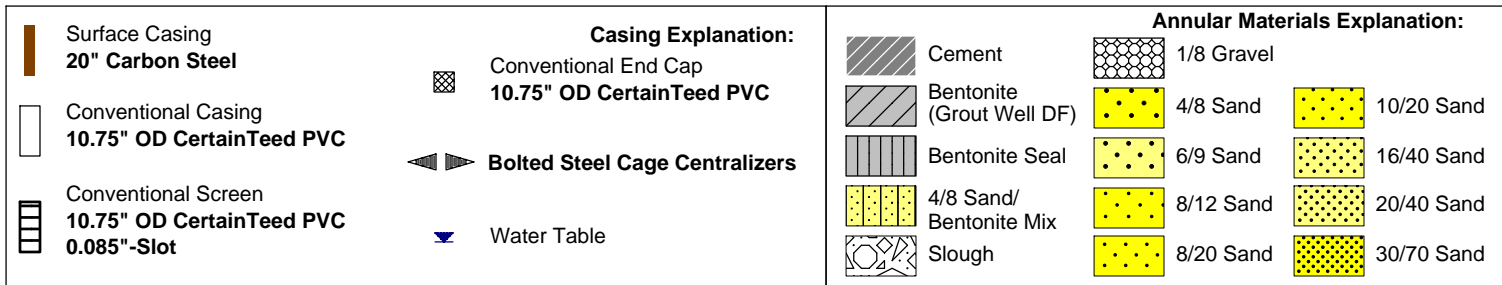

Feet/Meters	Well Descriptions All depths listed are bgs (unless noted)	Annular/Borehole Descriptions All depths listed are bgs
-------------	---	--

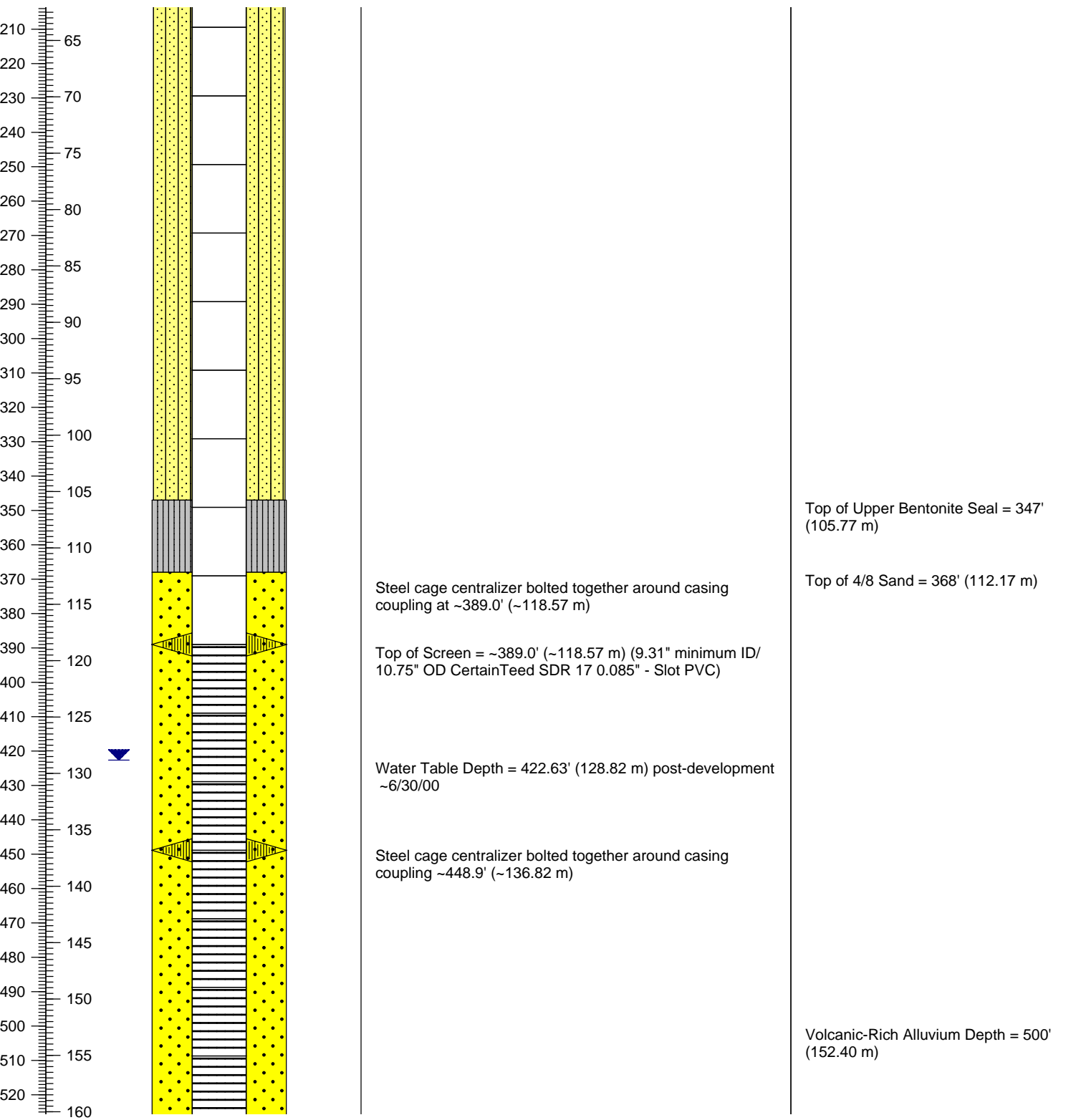

Surface Casing 20" Carbon Steel	Casing Explanation:	Cement	Annular Materials Explanation:	
Conventional Casing 10.75" OD CertainTeed PVC	Conventional End Cap 10.75" OD CertainTeed PVC	Bentonite (Grout Well DF)	1/8 Gravel	4/8 Sand
Conventional Screen 10.75" OD CertainTeed PVC 0.085"-Slot	Bolted Steel Cage Centralizers	Bentonite Seal	6/9 Sand	10/20 Sand
	Water Table	4/8 Sand/ Bentonite Mix	8/12 Sand	16/40 Sand
		Slough	8/20 Sand	20/40 Sand
			30/70 Sand	

Feet/Meters	Well Descriptions All depths listed are bgs (unless noted)	Annular/Borehole Descriptions All depths listed are bgs
-------------	--	---

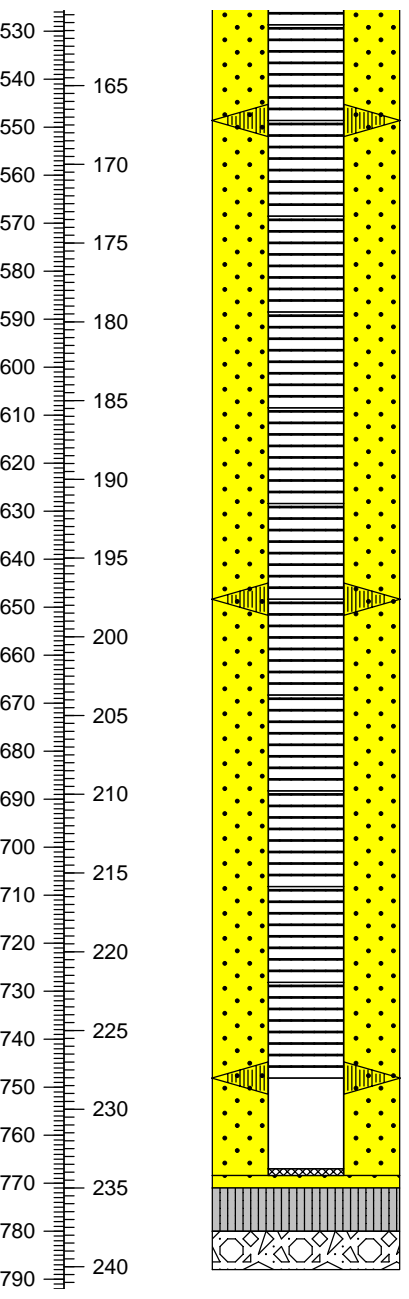

Steel cage centralizer bolted together around casing coupling ~548.6' (~167.21 m)

Steel cage centralizer bolted together around casing coupling ~648.4' (~197.63 m)

Bottom of Screen = ~748.10' (~228.02 m) (9.31" minimum ID/ 10.75" OD CertainTeed SDR 17 0.085" - Slot PVC)

Sump consists of 20' blank riser and end cap (end cap attached with spline).

Casing TD = ~768.40' (~234.21 m); 9.31" minimum ID; 10.75" OD CertainTeed SDR 17 PVC

Volcanic Andesite Bedrock Depth = 652' (198.73 m)

Top of Lower Bentonite Seal = 771' (235.00 m)

Top of Slough = 780' (237.74 m) from Geophysics

17 1/2" Borehole TD = 788' (240.18)

WELL COMPLETION DIAGRAM

EXTRACTION WELL

Location ID: **PFE-2**

Site ID: **NASA-WSTF, Doña Ana County, NM**

Township and Range: **SW 1/4, SW 1/4, SE 1/4, Sec 32, T20S, R3E**
 Site Coordinates: **168557.65 N/461907.38 E**
 Elevation (Ground Surface): **Below Grade Vault**
 Elevation (Top of Casing): **1372.40 m**
 Drilling Contractor: **Stewart Brothers Drilling Company**
 Driller: **Juan Aguilar**
 Total Depth of Borehole (bgs): **912' (278.0 m)**
 Borehole Diameter: **17 1/2" 0-100'; reamed 26"; 17 1/2" 100-912'**
 Depth to Bedrock (bgs): **700' (213.4 m; Andesite)**
 Depth to Groundwater: **434.02' (132.29 m; measured 7/21/00)**
 Total Depth Surface Casing (bgs): **100' (30.5 m)**
 Diameter and Type Surface Casing: **19.5" ID; 20" OD Carbon Steel**

Date(s) Well Installed: **2/20/00-2/22/00**
 Date(s) Well Developed: **4/15-17/00 bailing; 7/11-12/00; 7/21/00 pumping**
 Field Representative(s): **See Annular Descriptions**
 Total Depth Well Casing (bgs): **896.2' (273.2 m)**
 Type of Casing: **CertainTeed PVC**
 Diameter Well Casing: **9.31" min. ID; 10.75" OD**
 Casing Schedule: **SDR 17**
 Screened Zone (bgs): **397.5-875.8' (121.2-266.9 m)**
 Comments: **Well completed as an extraction well below grade in a cement vault**
Flushed casing with clean water 2/23/00

Casing Explanation:		Annular Materials Explanation:		
Surface Casing 20" Carbon Steel	Conventional End Cap 10.75" OD CertainTeed PVC	Cement	1/8 Gravel	
Conventional Casing 10.75" OD CertainTeed PVC	Bolted Steel Cage Centralizers	Bentonite (Grout Well DF)	4/8 Sand	10/20 Sand
Conventional Screen 10.75" OD CertainTeed PVC 0.085"-Slot	Water Table	Bentonite Seal	6/9 Sand	16/40 Sand
		4/8 Sand/ Bentonite Mix	8/12 Sand	20/40 Sand
		Slough	8/20 Sand	30/70 Sand

Feet/Meters

Well Descriptions	Annular/Borehole Descriptions
All depths listed are bgs (unless noted)	All depths listed are bgs

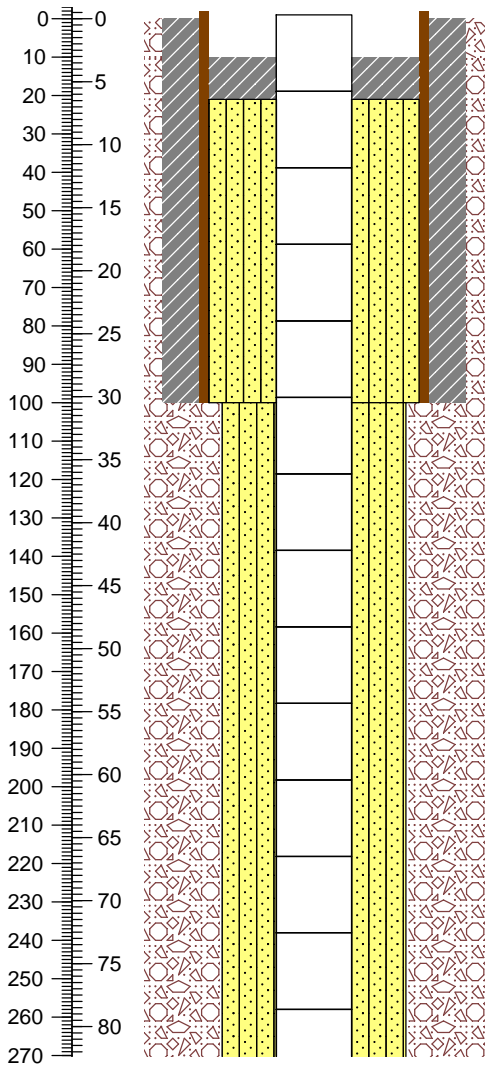

Stick-Up = ~1' (0.3 m) ags installed at installation. Casing was later cut below ground surface as well was completed within a cement well vault.

Surface Casing Stick-Up = 2' (0.6 m) ags at installation. Later cut below ground surface as well was completed within a cement well vault.

20" OD Carbon Steel Surface Casing Depth = 100' (30.5 m)

Top of Cement Grout (Portland II) = ~10' (3.0 m)

Top of 4/8 Sand/Bentonite Mix = 21' (6.4 m)

Field Representatives: Mary Canavan; Geoff Giles; Lela Hunnicutt-Mack; Jack Kirby; John Pearson; and Murray Stepro

The formation is Santa Fe Group Alluvium from surface to 525' (160.0 m)

17 1/2" Borehole cemented to 100' (30.5 m)

Surface Casing 20" Carbon Steel	Casing Explanation:	Cement	Annular Materials Explanation:	
Conventional Casing 10.75" OD CertainTeed PVC	Conventional End Cap 10.75" OD CertainTeed PVC	Bentonite (Grout Well DF)	1/8 Gravel	4/8 Sand
Conventional Screen 10.75" OD CertainTeed PVC 0.085"-Slot	Bolted Steel Cage Centralizers	Bentonite Seal	6/9 Sand	10/20 Sand
	Water Table	4/8 Sand/ Bentonite Mix	8/12 Sand	16/40 Sand
		Slough	8/20 Sand	20/40 Sand
			30/70 Sand	

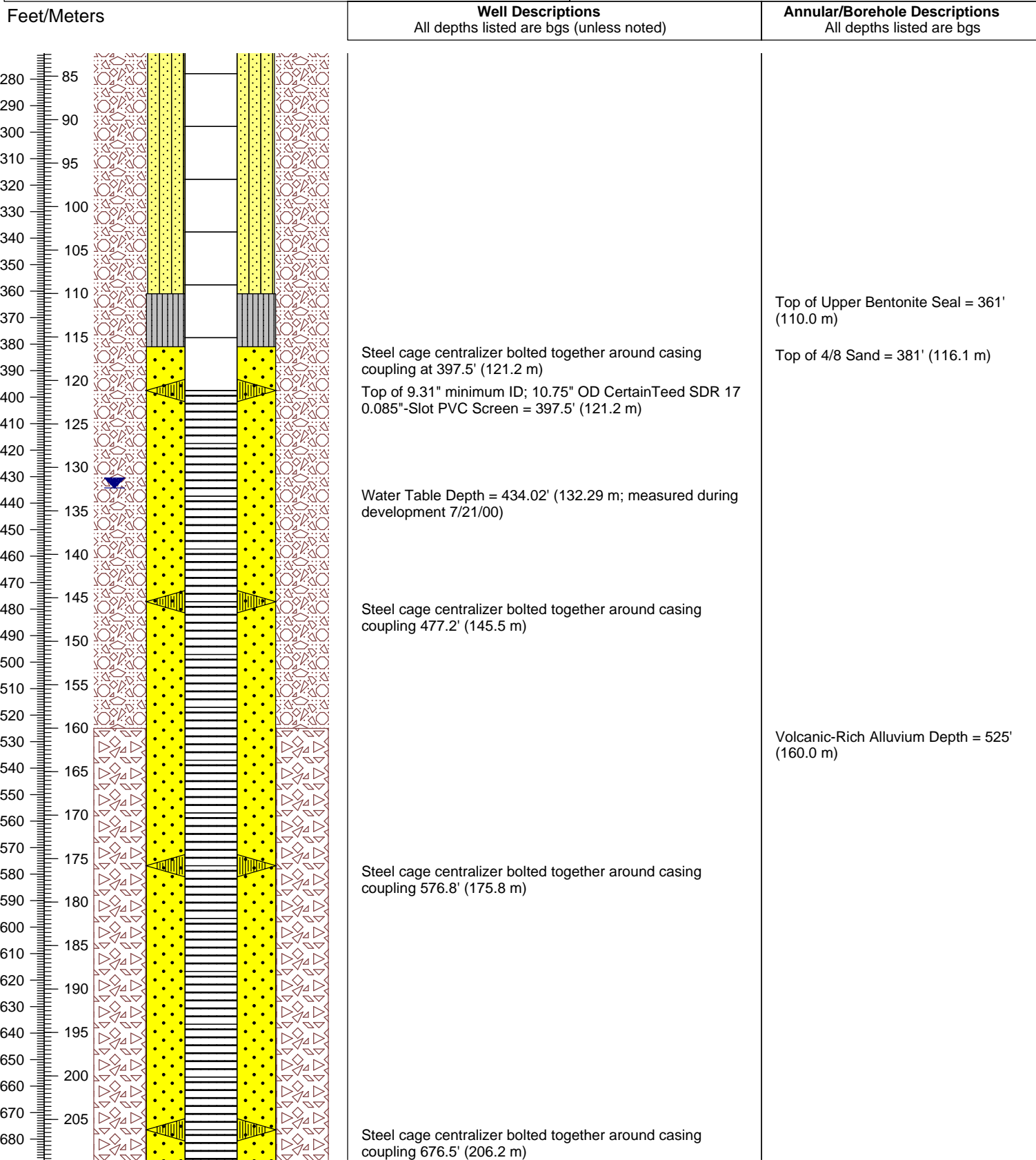

Surface Casing 20" Carbon Steel	Casing Explanation:	Cement	Annular Materials Explanation:	
Conventional Casing 10.75" OD CertainTeed PVC	Conventional End Cap 10.75" OD CertainTeed PVC	Bentonite (Grout Well DF)	1/8 Gravel	4/8 Sand
Conventional Screen 10.75" OD CertainTeed PVC	Bolted Steel Cage Centralizers	Bentonite Seal	6/9 Sand	10/20 Sand
0.085"-Slot	Water Table	4/8 Sand/ Bentonite Mix	8/12 Sand	16/40 Sand
		Slough	8/20 Sand	20/40 Sand
			30/70 Sand	

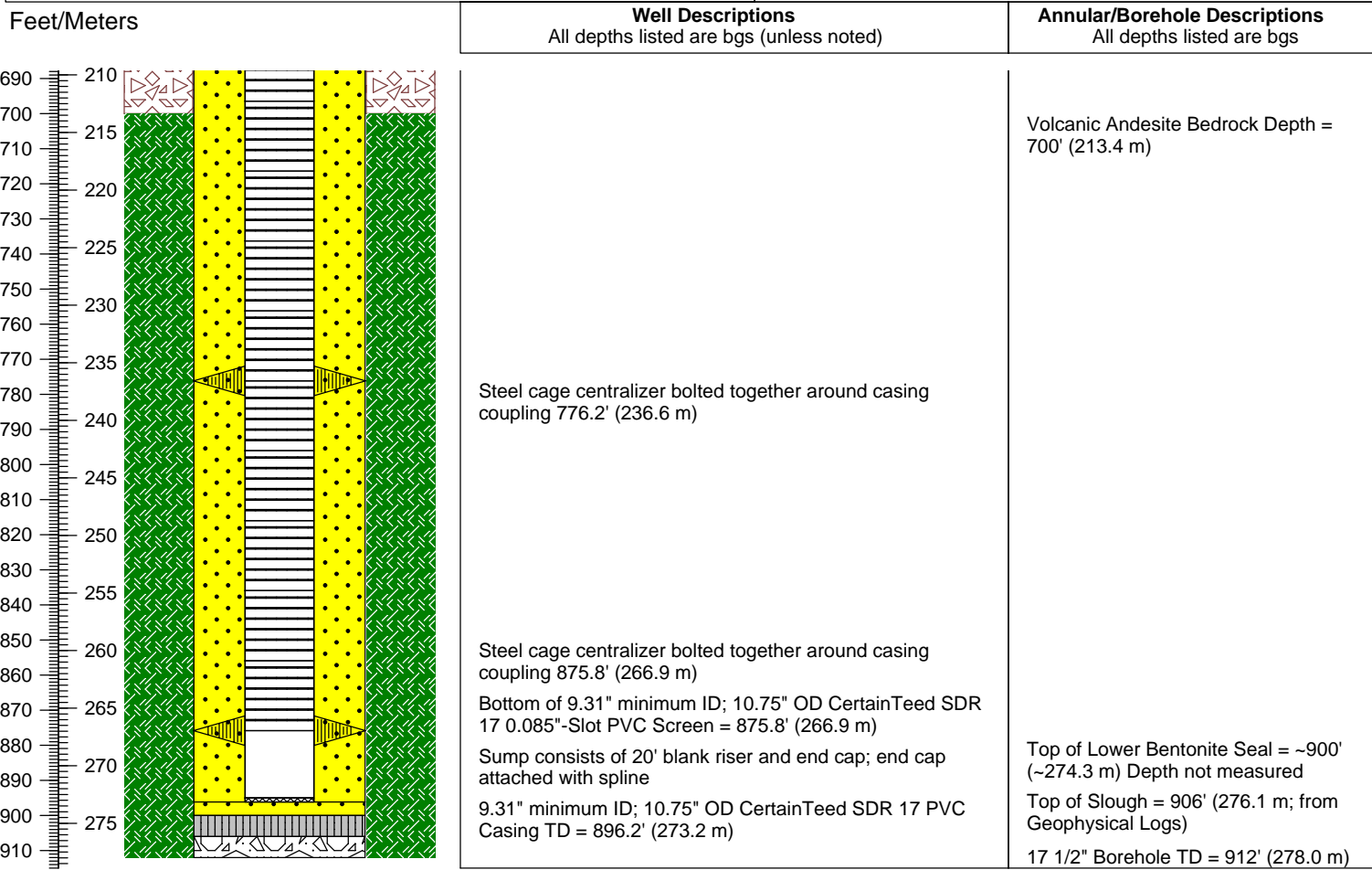

WELL COMPLETION DIAGRAM

EXTRACTION WELL

Location ID: **PFE-3**

Site ID: **NASA-WSTF, Doña Ana County, NM**

Township and Range: **SW 1/4, NE 1/4, NE 1/4, Sec 5, T21S, R3E**
 NM State Plane Coordinates (NAD 83 in meters): **168015.96 N/462277.63 E**
 Elevation (Brass Cap): **N/A**
 Elevation (Top of Casing): **1379.35 m**
 Drilling Contractor: **Larjon Drilling Company**
 Driller: **Tommy Crawford; Jim Gower**
 Total Depth of Borehole (bgs): **856' (260.9 m)**
 Borehole Diameter: **16" 0-79'; 7 7/8" pilot; reamed 17 7/8" 79-856'; cored**
 Depth to Bedrock (bgs): **844' (257.3 m)**
 Depth to Groundwater: **452.44' (137.90 m); 459' (139.9 m; 1/16/03)**
 Total Depth Surface Casing (bgs): **79.5' (temporary)**
 Diameter and Type Surface Casing: **10" temporary steel casing; pulled 12/6/89**
 Date(s) Well Installed: **O = 12/19/89-1/5/90; I = 1/22/03-1/24/03**
 Date(s) Well Developed: **O = 1/9/90-1/12/90; 3/29/90; I = 1/25/03-1/29/03**

Field Representative(s): **See Annular Descriptions**
 Total Depth Outer Well Casing (bgs): **838.5' (255.6 m)**
 Total Depth Inner Well Casing (bgs): **836.1' (254.8 m)**
 Type of Casing(s): **O = Carbon Steel; I = CertainTeed PVC**
 Diameter Well Casing(s): **O = 10.02 ID; 10.5 OD; I = 6.13" ID; 6.90" OD**
 Casing Schedule(s): **O = Not Recorded; I = SDR 21**
 Outer Casing Screened Zone (bgs): **507.7-828.4' (154.7-252.5 m)**
 ~20' Screens welded to ~10' blanks
 Inner Casing Screened Zone (bgs): **477.1-816.0' (145.4-248.7 m) ~10' S with**
 ~10' B; then 3x~10' Ss with ~10' Bs
 Comments: **Well completed as an extraction well below grade in a cement vault; O = Outer Casing; I = Inner Casing**
Well pump tested 5/23/90 (step-drawdown); 6/4/90-6/17/90 (pump test and recovery) S = screen; B = blank

<p> Surface Casing 10" steel temporary</p> <p> 10" ID Carbon Steel</p> <p> 10" ID Carbon Steel 0.080"-Slot Screen</p> <p> 10" ID Carbon Steel End Cap</p>	<p>Casing Explanation:</p> <p> Water Table</p> <p> 6.05" ID CertainTeed PVC</p> <p> 6.05" ID CertainTeed PVC 0.050"-Slot Screen</p> <p> 6.05" ID CertainTeed PVC End Cap</p>	<p>Annular Materials Explanation:</p> <p> Cement</p> <p> Bentonite (Grout Well DF)</p> <p> Bentonite Seal</p> <p> 10/20 Sand/Bentonite Mix</p> <p> Slough</p> <p> 1/8 Gravel</p> <p> 4/8 Sand</p> <p> 6/9 Sand</p> <p> 8/12 Sand</p> <p> 8/20 Sand</p> <p> 10/20 Sand</p> <p> 16/40 Sand</p> <p> 20/40 Sand</p> <p> 30/70 Sand</p>	<p>Lithology Explanation:</p> <p> Alluvium</p> <p> Volcanic-Rich Alluvium</p> <p> Limestone</p> <p> Sandstone</p> <p> Shale</p> <p> Andesite</p> <p> Rhyolite</p> <p> Undifferentiated Volcanics</p>
---	--	---	---

Welded Centralizers

Feet/Meters

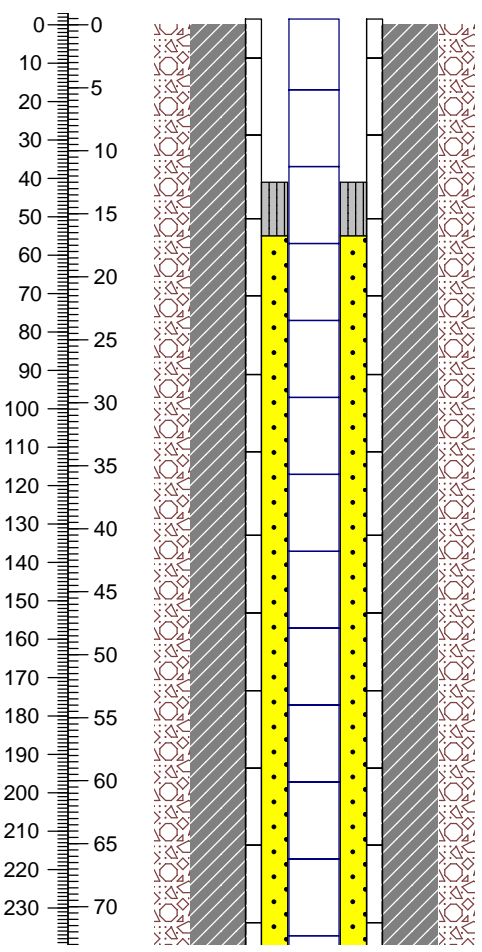

Well Descriptions All depths listed are bgs (unless noted)	Annular/Borehole Descriptions All depths listed are bgs
--	---

Stick-Up = ~11.4' (3.5 m) ags installed at installation. Cut to ~1.5' (0.5 m). Casing was later cut below ground surface as well was completed within a cement well vault.

No Surface Casing

Stick-Up = 3.11' (0.9 m) ags installed at installation to sit level on flange of carbon steel well. Casing was later cut below ground surface as well was completed within a cement well vault.

Carbon steel casing welded together. Schedule of casing not recorded.

Top of Cement Grout (Portland II) = 0'

Field Representatives: Greg Contaldo; Robert Cooper; Pam Egan; Jack Kirby; and Earl Morse

The formation is Santa Fe Group Alluvium from surface to 500' (152.4 m)

Surface Casing 10" steel temporary	Water Table	Cement	1/8 Gravel
10" ID Carbon Steel	6.05" ID CertainTeed PVC	Bentonite (Grout Well DF)	4/8 Sand
10" ID Carbon Steel 0.080"-Slot Screen	6.05" ID CertainTeed PVC 0.050"-Slot Screen	Bentonite Seal	6/9 Sand
10" ID Carbon Steel End Cap	6.05" ID CertainTeed PVC End Cap	10/20 Sand/Bentonite Mix	8/12 Sand
Welded Centralizers		Slough	8/20 Sand
Alluvium	Volcanic-Rich Alluvium	Limestone	Sandstone
Shale	Andesite	Rhyolite	Undifferentiated Volcanics

Feet/Meters	Well Descriptions All depths listed are bgs (unless noted)	Annular/Borehole Descriptions All depths listed are bgs
--------------------	--	---

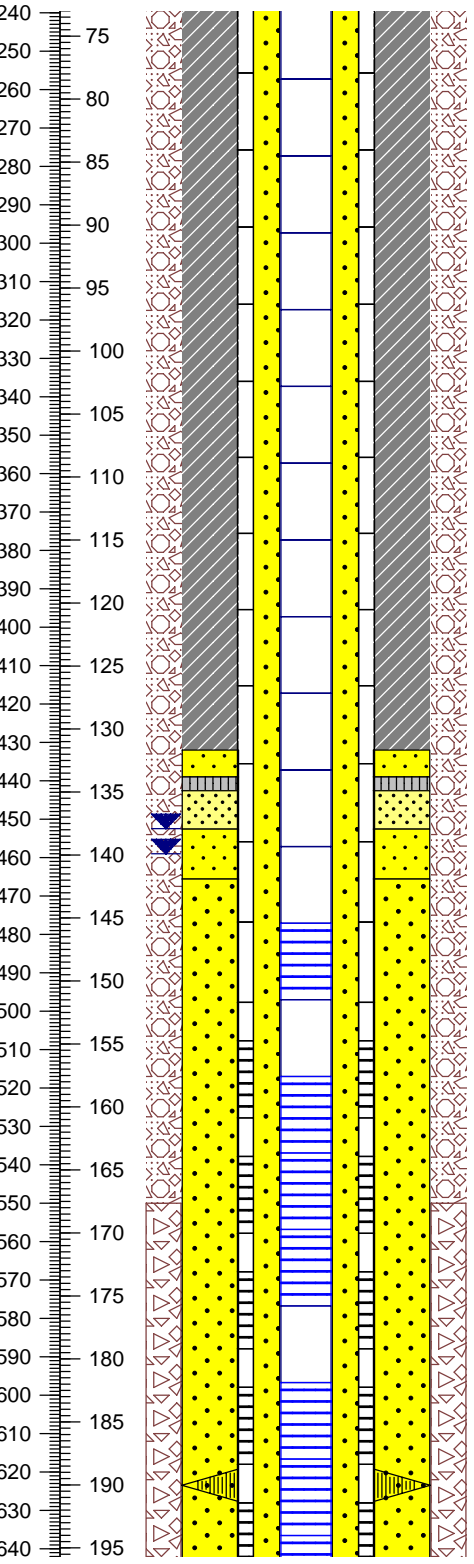

Water Table Depth = 452.44' (137.90 m TOC; measured, date unknown)

Water Table Depth = 459' (139.9 m bgs; from camera log counter 1/16/03)

6.9" OD PVC casing screened zone made up of one 20' screen, one 20' blank, then three 20' screens separated by 20' blanks.

Top of 6.13" minimum ID (6.05" ID measured); 6.9" OD CertainTeed SDR 21 0.050"-Slot PVC Screen = 477.1' (145.4 m)

10.02" ID Carbon Steel Screened zone made up of 20' screens welded to 10' blank sections.

Top of 10.02" ID; 10.75" OD Carbon Steel Continuous Wire Wound 0.080"-Slot Screen = 507.7' (154.7 m)

Three stainless steel centralizers welded to casing at 623.5' (190.0 m)

Top of 8/20 Sand = ~432' (~131.7 m)(Exact depth not measured due to malfunctioning probe)

Top of Bentonite Seal = ~439' (133.8 m)(Exact depth not measured due to malfunctioning probe)

Top of 16/40 Sand = ~442.6' (~134.9 m)(Exact depth not measured due to malfunctioning probe)

Top of 8/20 Sand = ~452.6' (~138.0 m)(Exact depth not measured due to malfunctioning probe)

Top of 4/8 Sand = 465.6' (141.9 m)

Volcanic-Rich Alluvium Depth = 550' (167.6 m)

Casing Explanation:		Annular Materials Explanation:	
Surface Casing	Water Table	Cement	1/8 Gravel
10" ID Carbon Steel	6.05" ID CertainTeed PVC	Bentonite (Grout Well DF)	4/8 Sand
10" ID Carbon Steel 0.080"-Slot Screen	6.05" ID CertainTeed PVC 0.050"-Slot Screen	Bentonite Seal	6/9 Sand
10" ID Carbon Steel End Cap	6.05" ID CertainTeed PVC End Cap	10/20 Sand/Bentonite Mix	8/12 Sand
Welded Centralizers		Slough	8/20 Sand

Lithology Explanation:			
Alluvium	Volcanic-Rich Alluvium	Limestone	Sandstone
Shale	Andesite	Rhyolite	Undifferentiated Volcanics

Feet/Meters	Well Descriptions All depths listed are bgs (unless noted)	Annular/Borehole Descriptions All depths listed are bgs
-------------	---	--

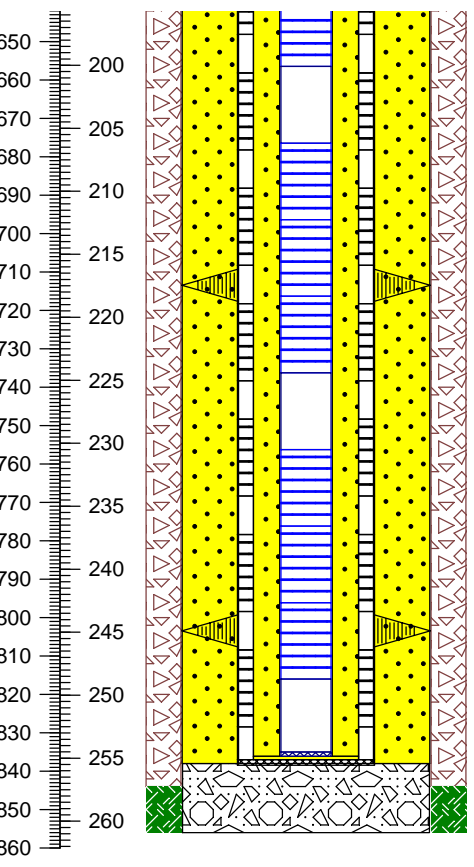

Three stainless steel centralizers welded to casing at 713.5' (217.5 m)

Three stainless steel centralizers welded to casing at 803.5' (244.9 m)

Bottom of 6.13" minimum ID (6.05" ID measured); 6.9" OD CertainTeed SDR 21 0.050"-Slot PVC Screen = 816.0' (248.7 m)

Bottom of 10.02" ID; 10.75" OD Carbon Steel Continuous Wire Wound 0.080"-Slot Screen = 828.4' (252.5 m)

Sump consists of 20' blank riser with end cap attached with spline

Sump consists of 10' blank riser with end cap tapered and welded on

6.13" minimum ID (6.05" ID measured); 6.9" OD CertainTeed SDR 21 PVC Casing TD = 836.1' (254.8 m)

10.02" ID; 10.75" OD Carbon Steel Casing TD = 838.5' (255.6 m)

Top of Slough = 838' (255.4 m; casing installed to bottom with slough 12/20/89)

Volcanic Andesite Bedrock Depth = 844' (257.3 m)

17 7/8" Borehole TD = 856' (260.9 m)

Location ID: **PFE-4A**

Site ID: **NASA-WSTF, Doña Ana County, NM**

Township and Range: **SW 1/4, SW 1/4, NW 1/4, Sec 4, T21S, R3E**
 Site Coordinates: **167616.47 N/462572.87 E**
 Elevation (Ground Surface): **Below Grade Vault**
 Elevation (Top of Casing): **1383.19 m**
 Drilling Contractor: **Stewart Brothers Drilling Company**
 Driller: **Davis Gaddy**
 Total Depth of Borehole (bgs): **720' (219.5 m)**
 Borehole Diameter: **17 1/2" 0-117'; reamed 26"; 17 1/2" 117-720'**
 Depth to Bedrock (bgs): **630' (192.0 m; Andesite)**
 Depth to Groundwater: **469.58' (143.13 m; measured 9/4/01)**
 Total Depth Surface Casing (bgs): **117' (35.7 m)**
 Diameter and Type Surface Casing: **19.5" ID; 20" OD Carbon Steel**

Date(s) Well Installed: **8/15/01-8/22/01**
 Date(s) Well Developed: **8/23-24/01 jetted; 8/25/01-9/5/01 pumping**
 Field Representative(s): **See Annular Descriptions**
 Total Depth Well Casing (bgs): **697.3' (212.5 m)**
 Type of Casing: **CertainTeed PVC**
 Diameter Well Casing: **9.31" min. ID; 10.75" OD**
 Casing Schedule: **SDR 17**
 Screened Zone (bgs): **398.0-677.3' (121.3-206.4 m)**
 Comments: **Well completed as an extraction well below grade in a cement vault**

Surface Casing	Casing Explanation:	Annular Materials Explanation:	
20" Carbon Steel	Conventional End Cap 10.75" OD CertainTeed PVC	Cement	1/8 Gravel
Conventional Casing 10.75" OD CertainTeed PVC	Bolted Steel Cage Centralizers	Bentonite (Grout Well DF)	4/8 Sand
Conventional Screen 10.75" OD CertainTeed PVC 0.085"-Slot	Water Table	Bentonite Seal	6/9 Sand
		4/8 Sand/ Bentonite Mix	8/12 Sand
		Slough	8/20 Sand
			10/20 Sand
			16/40 Sand
			20/40 Sand
			30/70 Sand

Feet/Meters

Well Descriptions	Annular/Borehole Descriptions
All depths listed are bgs (unless noted)	All depths listed are bgs

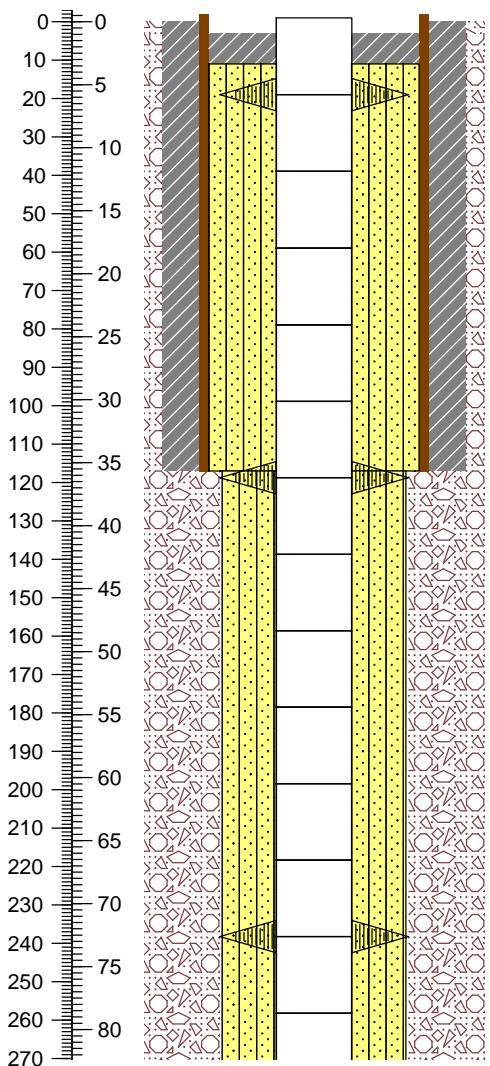

Stick-Up = ~1' (0.3 m) ags installed at installation. Casing was later cut below ground surface as well was completed within a cement well vault.

Surface Casing Stick-Up = 2' (0.6 m) ags at installation. Later cut below ground surface as well was completed within a cement well vault.

Steel cage centralizer bolted together around casing coupling at 19.0' (5.8 m)

20" OD Carbon Steel Surface Casing Depth = 117' (35.7 m)
 Steel cage centralizer bolted together around casing coupling at 118.8' (36.2 m)

Steel cage centralizer bolted together around casing coupling at 238.3' (72.6 m)

Top of Cement Grout (Portland II) = ~3' (0.9 m)

Top of 4/8 Sand/Bentonite Mix = 11' (3.4 m)

Field Representatives: Mary Canavan; Geoff Giles; Lela Hunnicutt-Mack; John Pearson; Murray Stepro; and Ron Weaver

The formation is Santa Fe Group Alluvium from surface to 480' (146.3 m)

17 1/2" Borehole cemented to 117' (35.7 m)

Surface Casing 20" Carbon Steel	Casing Explanation:	Cement	Annular Materials Explanation:	
Conventional Casing 10.75" OD CertainTeed PVC	Conventional End Cap 10.75" OD CertainTeed PVC	Bentonite (Grout Well DF)	1/8 Gravel	4/8 Sand
Conventional Screen 10.75" OD CertainTeed PVC	Bolted Steel Cage Centralizers	Bentonite Seal	6/9 Sand	10/20 Sand
0.085"-Slot	Water Table	4/8 Sand/ Bentonite Mix	8/12 Sand	16/40 Sand
		Slough	8/20 Sand	30/70 Sand

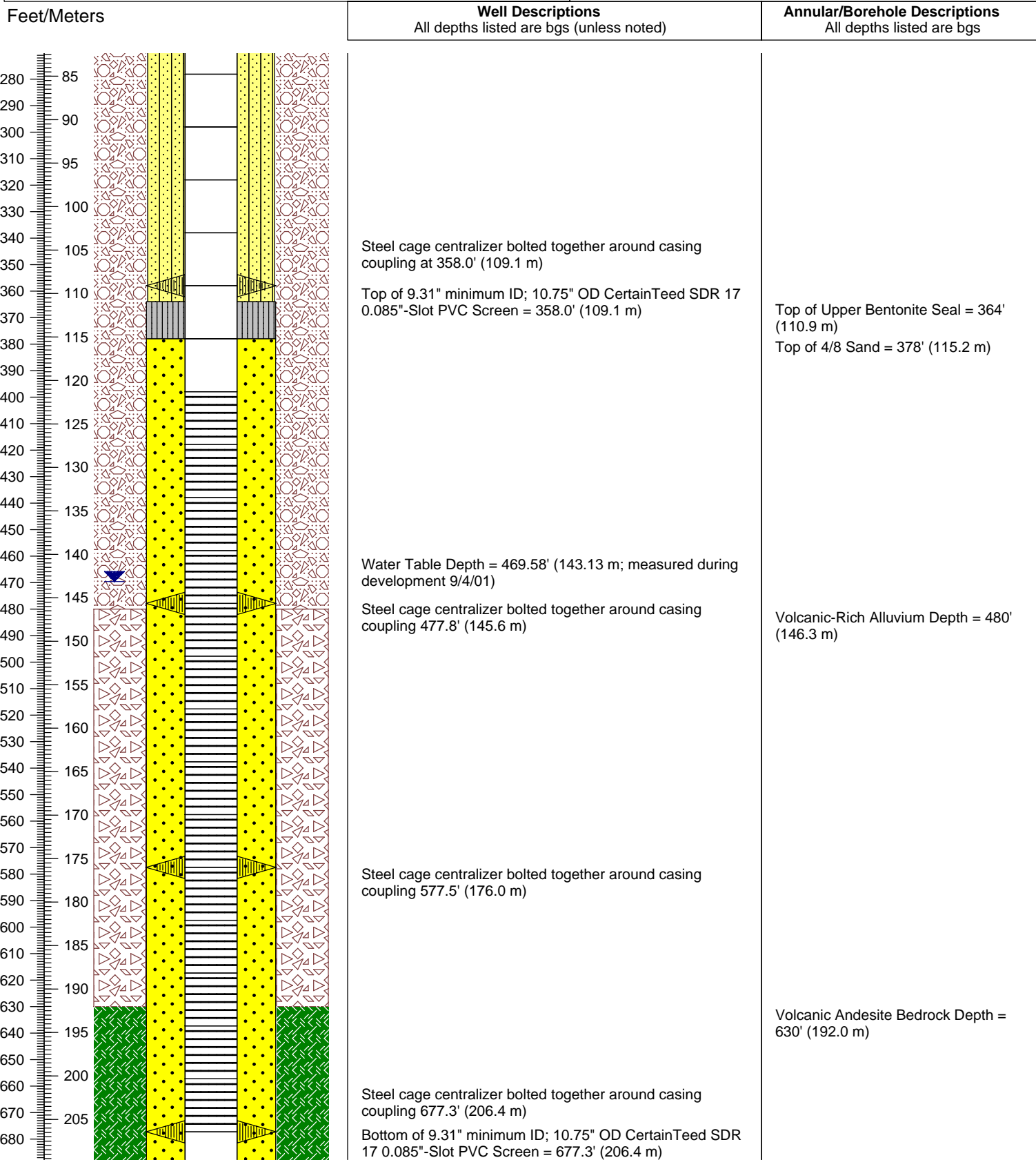

Steel cage centralizer bolted together around casing coupling at 358.0' (109.1 m)

Top of 9.31" minimum ID; 10.75" OD CertainTeed SDR 17 0.085"-Slot PVC Screen = 358.0' (109.1 m)

Water Table Depth = 469.58' (143.13 m; measured during development 9/4/01)

Steel cage centralizer bolted together around casing coupling 477.8' (145.6 m)

Steel cage centralizer bolted together around casing coupling 577.5' (176.0 m)

Steel cage centralizer bolted together around casing coupling 677.3' (206.4 m)

Bottom of 9.31" minimum ID; 10.75" OD CertainTeed SDR 17 0.085"-Slot PVC Screen = 677.3' (206.4 m)

Top of Upper Bentonite Seal = 364' (110.9 m)

Top of 4/8 Sand = 378' (115.2 m)

Volcanic-Rich Alluvium Depth = 480' (146.3 m)

Volcanic Andesite Bedrock Depth = 630' (192.0 m)

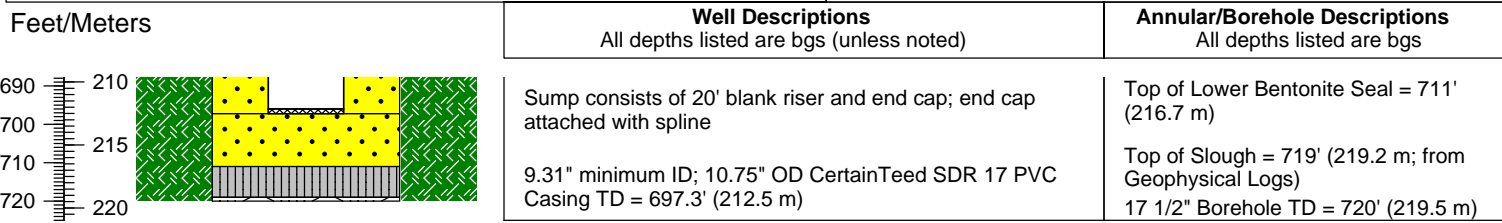
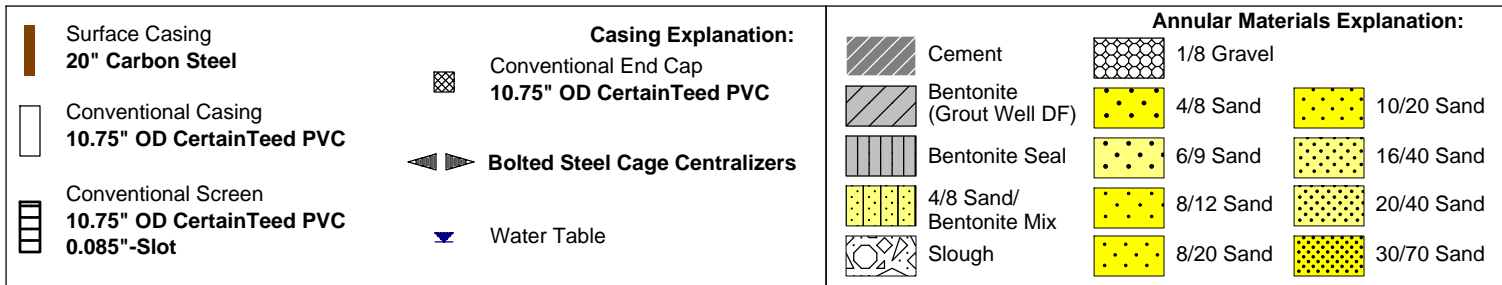

Location ID: **PFE-5**

Site ID: **NASA-WSTF, Doña Ana County, NM**

Township and Range: **NE 1/4, NW 1/4, SE 1/4, Sec 32, T20S, R3E**
 Site Coordinates: **168990.54 N/462227.93 E**
 Elevation (Ground Surface): **Below Grade Vault**
 Elevation (Top of Casing): **1377.96 m**
 Drilling Contractor: **Stewart Brothers Drilling Company**
 Driller: **Juan Aguilar**
 Total Depth of Borehole (bgs): **940' (286.5 m)**
 Borehole Diameter: **17 1/2" 0-100'; reamed 26"; 17 1/2" 100-940'**
 Depth to Bedrock (bgs): **590' (179.8 m; Latite)**
 Depth to Groundwater: **451.30' (137.56 m; measured 5/11/00)**
 Total Depth Surface Casing (bgs): **100' (30.5 m)**
 Diameter and Type Surface Casing: **19.5" ID; 20" OD Carbon Steel**

Date(s) Well Installed: **11/30/99-12/5/99**
 Date(s) Well Developed: **2/1-5/00 bailing; 4/20/00-5/11/00 pumping**
 Field Representative(s): **See Annular Descriptions**
 Total Depth Well Casing (bgs): **817.0' (249.0 m)**
 Type of Casing: **CertainTeed PVC**
 Diameter Well Casing: **7.85" min. ID; 9.05" OD**
 Casing Schedule: **SDR 17**
 Screened Zone (bgs): **418.0-797.0' (127.4-242.9 m)**
 Comments: **Well completed as an extraction well below grade in a cement vault**

Casing Explanation:		Annular Materials Explanation:		
Surface Casing 20" Carbon Steel	Conventional End Cap 9.05" OD CertainTeed PVC	Cement	1/8 Gravel	
Conventional Casing 9.05" OD CertainTeed PVC	Bolted Steel Cage Centralizers	Bentonite (Grout Well DF)	4/8 Sand	10/20 Sand
Conventional Screen 9.05" OD CertainTeed PVC 0.085"-Slot	Water Table	Bentonite Seal	6/9 Sand	16/40 Sand
		8/20 Sand & 1/8 Bentonite Mix	8/12 Sand	20/40 Sand
		Slough	8/20 Sand	30/70 Sand

Feet/Meters

Well Descriptions	Annular/Borehole Descriptions
All depths listed are bgs (unless noted)	All depths listed are bgs

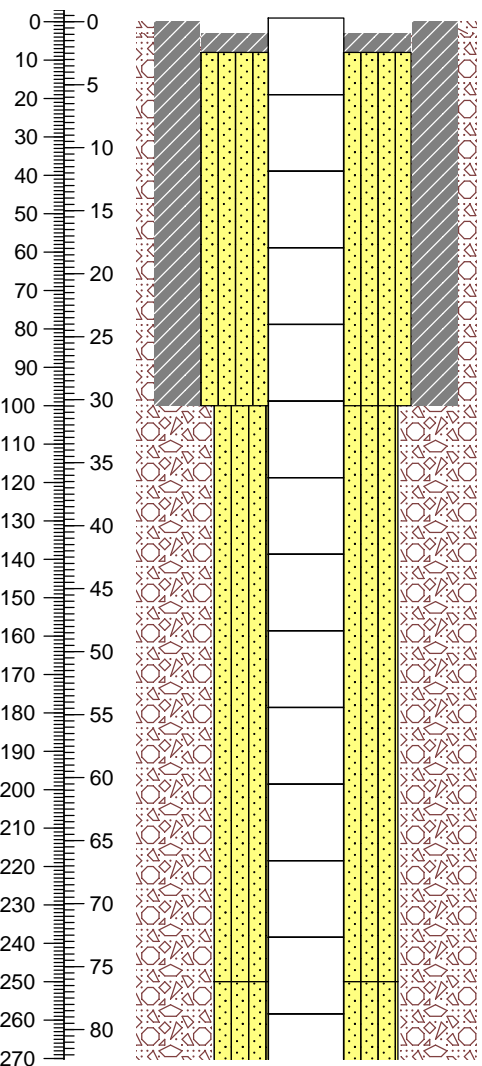

Stick-Up = -0.97' (0.3 m) ags installed at installation.

Surface Casing Stick-Up = 2' (0.6 m) ags at installation.

20" OD Carbon Steel Surface Casing Depth = 100' (30.5 m)

Top of Cement Grout (Portland II) = -3' (0.9 m)

Top of 8/20 Sand/Bentonite Mix = 8' (2.4 m)

Field Representatives: Mary Canavan; Geoff Giles; Lela Hunnicutt-Mack; Jack Kirby; John Pearson; Mark Rivera; and Murray Stepro

The formation is Santa Fe Group Alluvium from surface to 520' (158.5 m)

17 1/2" Borehole cemented to 100' (30.5 m)

Top of 1/8 Gravel/Bentonite Mix = 250' (76.2 m)

Surface Casing 20" Carbon Steel	Casing Explanation:	Cement	Annular Materials Explanation:	
Conventional Casing 9.05" OD CertainTeed PVC	Conventional End Cap 9.05" OD CertainTeed PVC	Bentonite (Grout Well DF)	1/8 Gravel	4/8 Sand
Conventional Screen 9.05" OD CertainTeed PVC	Bolted Steel Cage Centralizers	Bentonite Seal	6/9 Sand	10/20 Sand
Conventional Screen 9.05" OD CertainTeed PVC	Water Table	8/20 Sand & 1/8 Gravel	8/12 Sand	16/40 Sand
Conventional Screen 0.085"-Slot		Bentonite Mix	8/20 Sand	20/40 Sand
		Slough	8/20 Sand	30/70 Sand

Feet/Meters	Well Descriptions All depths listed are bgs (unless noted)	Annular/Borehole Descriptions All depths listed are bgs
--------------------	--	---

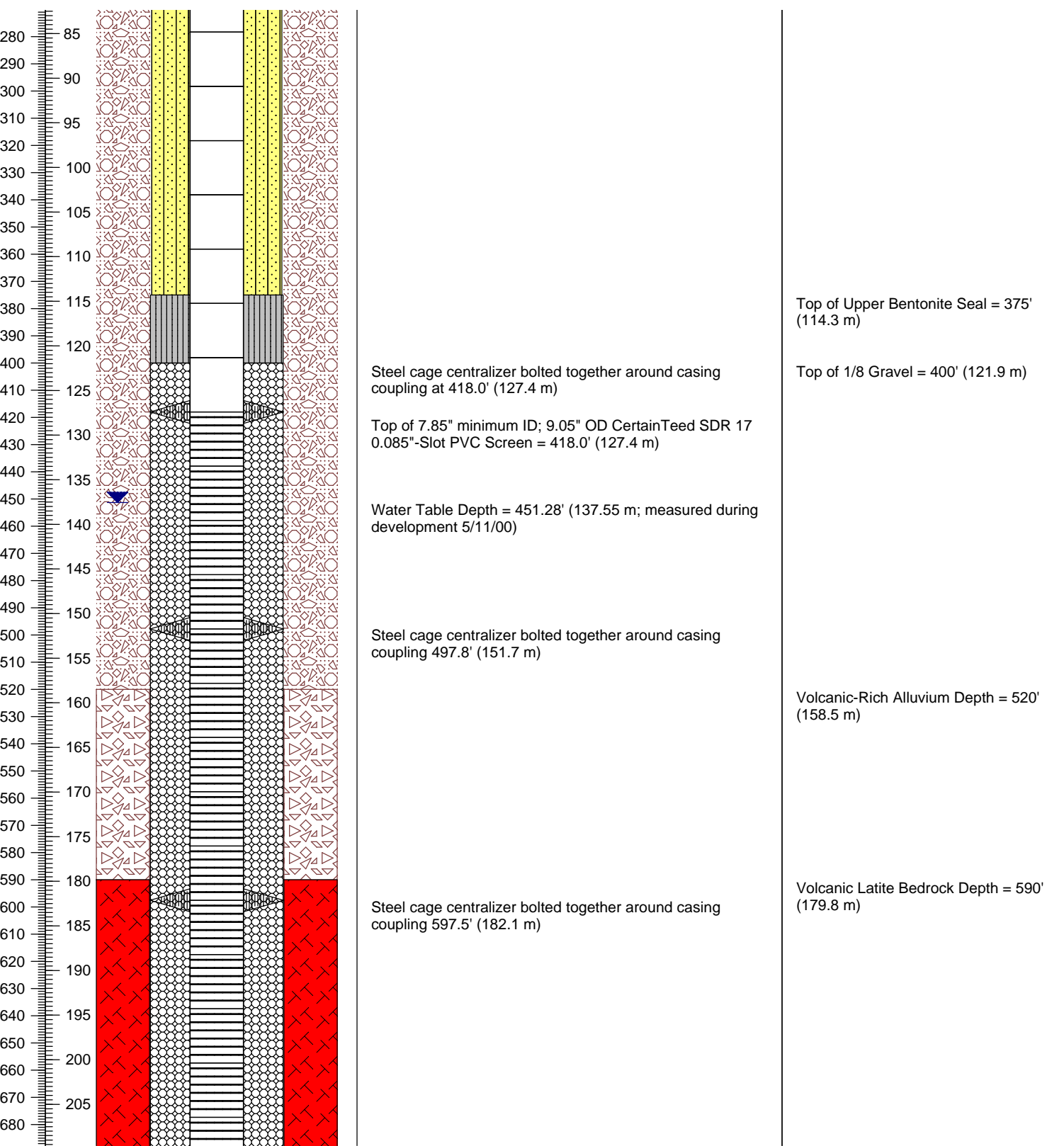

Surface Casing 20" Carbon Steel	Casing Explanation:	Cement	1/8 Gravel
Conventional Casing 9.05" OD CertainTeed PVC	Conventional End Cap 9.05" OD CertainTeed PVC	Bentonite (Grout Well DF)	4/8 Sand
Conventional Screen 9.05" OD CertainTeed PVC 0.085"-Slot	Bolted Steel Cage Centralizers	Bentonite Seal	6/9 Sand
	Water Table	8/20 Sand & 1/8 Gravel Bentonite Mix	8/12 Sand
		Slough	10/20 Sand
			16/40 Sand
			20/40 Sand
			30/70 Sand

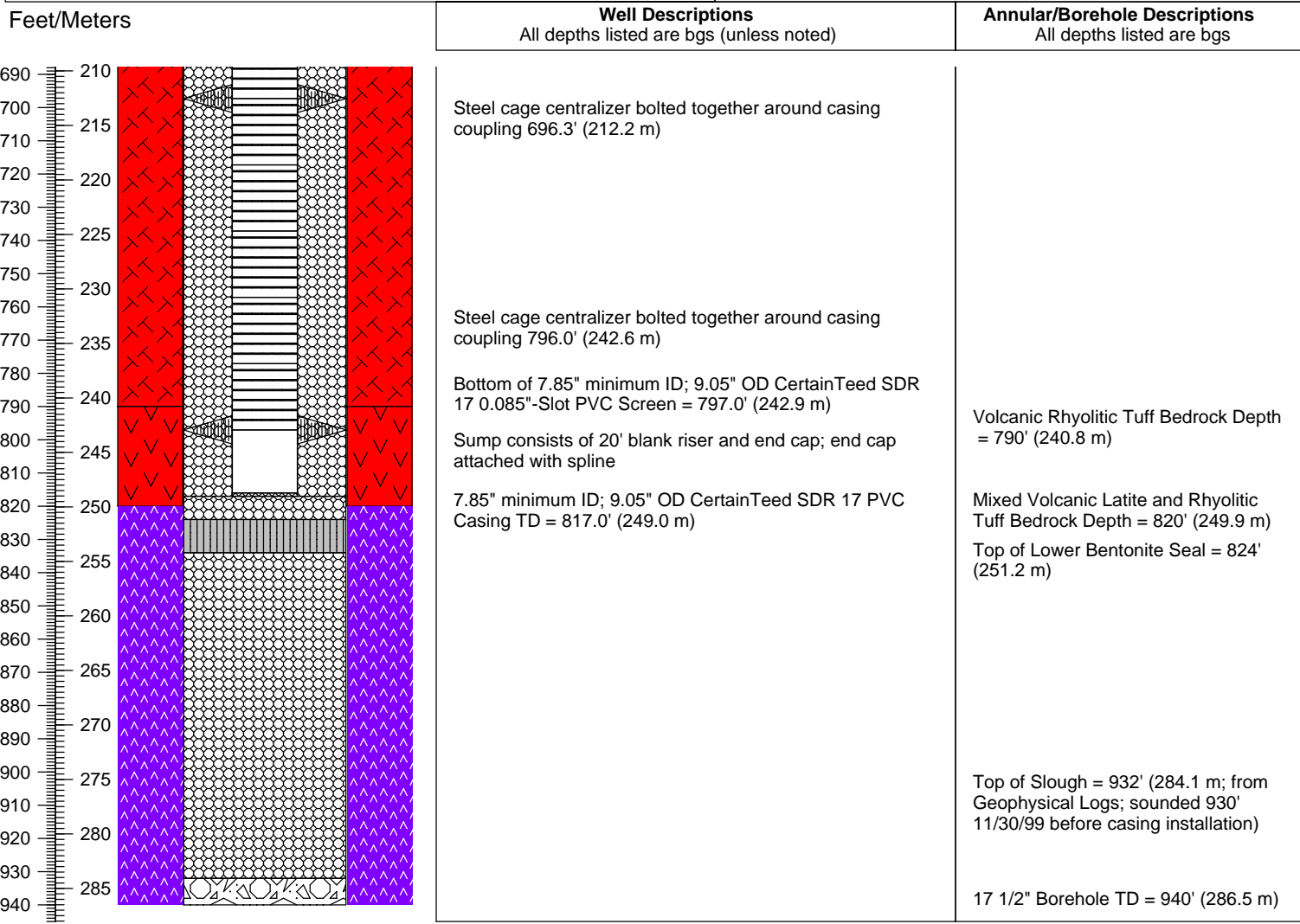





















Location ID: **PFE-7**

Site ID: **NASA-WSTF, Doña Ana County, NM**

Township and Range: **NE 1/4, SW 1/4, SW 1/4, Sec 32, T20S, R3E**
 Site Coordinates: **168738.66 N/461492.98 E**
 Elevation (Ground Surface): **Below Grade Vault**
 Elevation (Top of Casing): **1365.37 m**
 Drilling Contractor: **Stewart Brothers Drilling Company**
 Driller: **Davis Gaddy**
 Total Depth of Borehole (bgs): **720' (219.5 m)**
 Borehole Diameter: **17 1/2" 0-117'; reamed 26"; 17 1/2" 117-720'**
 Depth to Bedrock (bgs): **Not Reached**
 Depth to Groundwater: **412.11' (125.61 m; measured 8/27/01)**
 Total Depth Surface Casing (bgs): **117' (35.7 m)**
 Diameter and Type Surface Casing: **19.5" ID; 20" OD Carbon Steel**

Date(s) Well Installed: **7/25/01-7/29/01**
 Date(s) Well Developed: **7/29/01 jetted; 8/27/01 pumping**
 Field Representative(s): **See Annular Descriptions**
 Total Depth Well Casing (bgs): **697.6' (212.6 m)**
 Type of Casing: **CertainTeed PVC**
 Diameter Well Casing: **9.31" min. ID; 10.75" OD**
 Casing Schedule: **SDR 17**
 Screened Zone (bgs): **398.0-677.6' (121.3-206.5 m)**
 Comments: **Well completed as an extraction well below grade in a cement vault**

Casing Explanation:		Annular Materials Explanation:		
 Surface Casing 20" Carbon Steel	 Conventional End Cap 10.75" OD CertainTeed PVC	 Cement	 1/8 Gravel	
 Conventional Casing 10.75" OD CertainTeed PVC	 Bolted Steel Cage Centralizers	 Bentonite (Grout Well DF)	 4/8 Sand	 10/20 Sand
 Conventional Screen 10.75" OD CertainTeed PVC 0.085"-Slot	 Water Table	 Bentonite Seal	 6/9 Sand	 16/40 Sand
		 4/8 Sand/Bentonite Mix	 8/12 Sand	 20/40 Sand
		 Slough	 8/20 Sand	 30/70 Sand

Feet/Meters

Well Descriptions
All depths listed are bgs (unless noted)

Annular/Borehole Descriptions
All depths listed are bgs

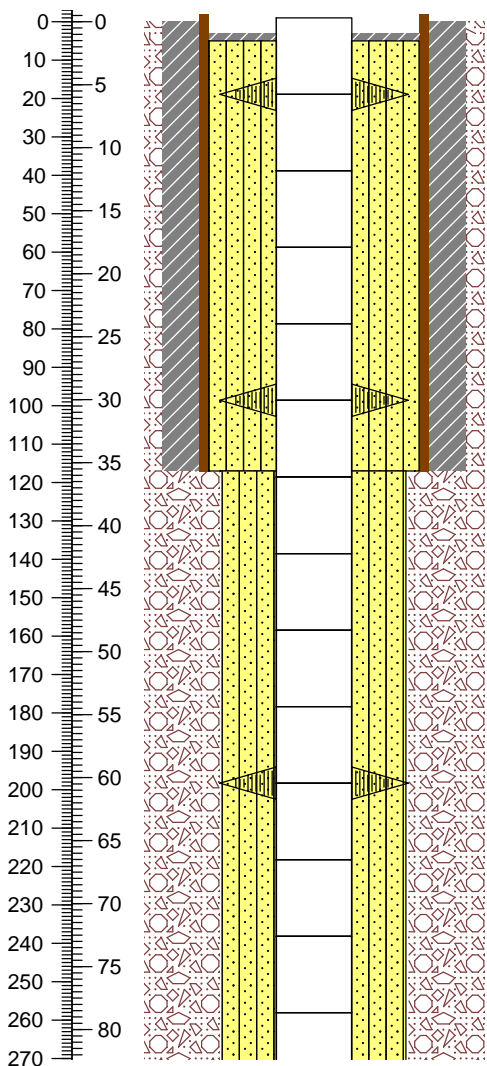

Stick-Up = ~1' (0.3 m) ags installed at installation. Casing was later cut below ground surface as well was completed within a cement well vault.

Surface Casing Stick-Up = 2' (0.6 m) ags at installation. Later cut below ground surface as well was completed within a cement well vault.

Steel cage centralizer bolted together around casing coupling at 18.9' (5.8 m)

NOTE: Number and locations of centralizers were not recorded at installation. Centralizers assumed to have been installed per the well design.

Steel cage centralizer bolted together around casing coupling at 98.6' (30.1 m)

20" OD Carbon Steel Surface Casing Depth = 117' (35.7 m)

Steel cage centralizer bolted together around casing coupling at 198.3' (60.4 m)

Top of Cement Grout (Portland II) = ~3' (0.9 m)

Top of 4/8 Sand/Bentonite Mix = 5' (1.5 m)

Field Representatives: Mary Canavan; Geoff Giles; Lela Hunnicutt-Mack; John Pearson; Murray Stepro; and Ron Weaver

The formation is Santa Fe Group Alluvium from surface to 480' (146.3 m)

17 1/2" Borehole cemented to 117' (35.7 m)

Surface Casing 20" Carbon Steel	Casing Explanation:	Cement	Annular Materials Explanation:	
Conventional Casing 10.75" OD CertainTeed PVC	Conventional End Cap 10.75" OD CertainTeed PVC	Bentonite (Grout Well DF)	1/8 Gravel	4/8 Sand
Conventional Screen 10.75" OD CertainTeed PVC	Bolted Steel Cage Centralizers	Bentonite Seal	6/9 Sand	10/20 Sand
Conventional Screen 10.75" OD CertainTeed PVC	Water Table	4/8 Sand/ Bentonite Mix	8/12 Sand	16/40 Sand
Conventional Screen 0.085"-Slot		Slough	8/20 Sand	30/70 Sand

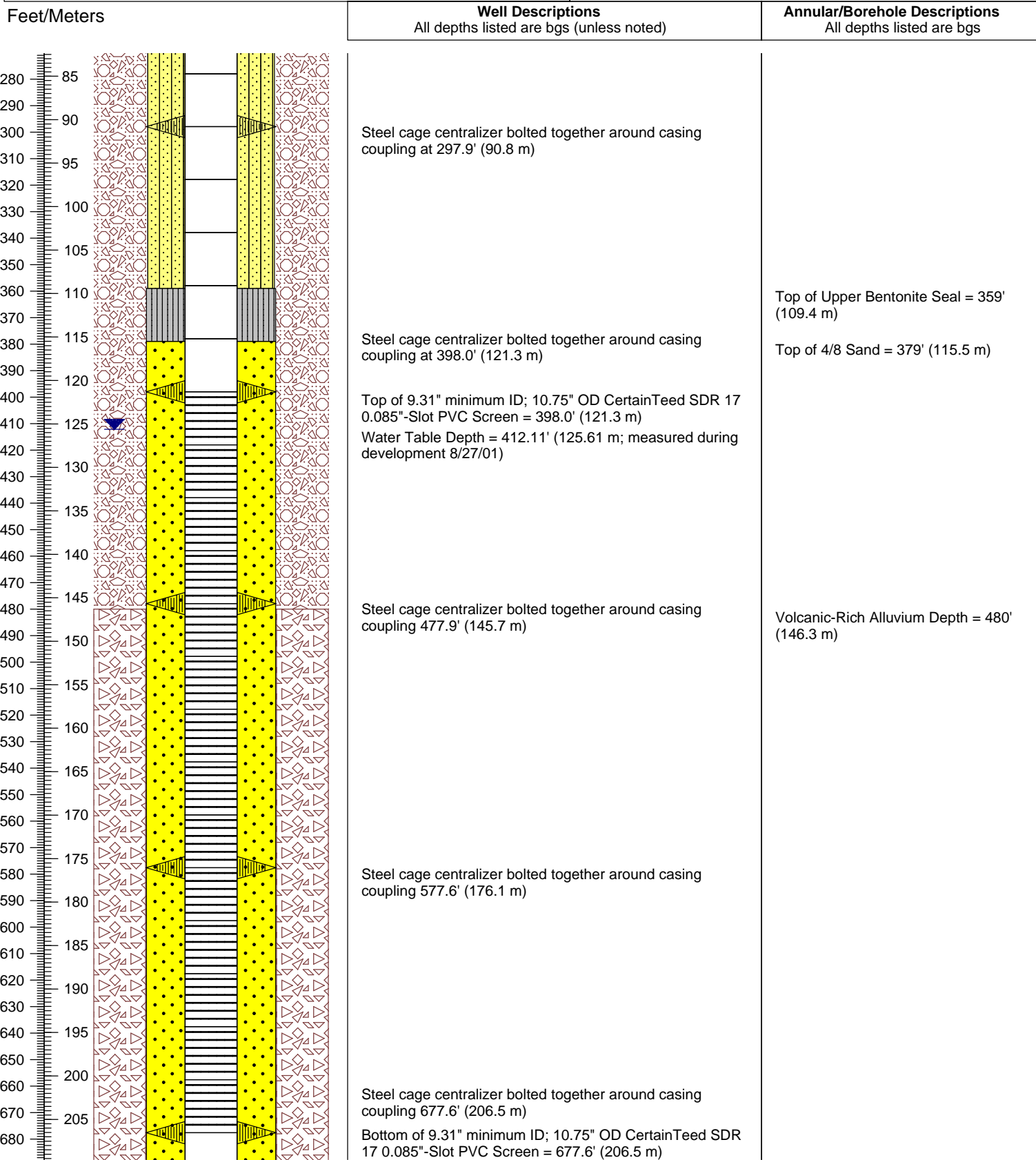

<p>Surface Casing 20" Carbon Steel</p> <p>Conventional Casing 10.75" OD CertainTeed PVC</p> <p>Conventional Screen 10.75" OD CertainTeed PVC 0.085"-Slot</p>	<p>Casing Explanation:</p> <p>Conventional End Cap 10.75" OD CertainTeed PVC</p> <p>Bolted Steel Cage Centralizers</p> <p>Water Table</p>	<p>Cement</p> <p>Bentonite (Grout Well DF)</p> <p>Bentonite Seal</p> <p>4/8 Sand/ Bentonite Mix</p> <p>Slough</p>	<p>Annular Materials Explanation:</p> <p>1/8 Gravel</p> <p>4/8 Sand</p> <p>6/9 Sand</p> <p>8/12 Sand</p> <p>8/20 Sand</p> <p>10/20 Sand</p> <p>16/40 Sand</p> <p>20/40 Sand</p> <p>30/70 Sand</p>
--	--	---	--

Feet/Meters	Well Descriptions All depths listed are bgs (unless noted)	Annular/Borehole Descriptions All depths listed are bgs
<p>690 210</p> <p>700 215</p> <p>710</p> <p>720 220</p>	<p>Sump consists of 20' blank riser and end cap; end cap attached with spline</p> <p>9.31" minimum ID; 10.75" OD CertainTeed SDR 17 PVC Casing TD = 697.6' (212.6 m)</p>	<p>Top of Lower Bentonite Seal = 712' (217.0 m)</p> <p>No Slough</p> <p>17 1/2" Borehole TD = 720' (219.5 m)</p>

WELL COMPLETION DIAGRAM

INJECTION WELL

Location ID: **PFI-2**

Site ID: **NASA-WSTF, Doña Ana County, NM**

Township and Range: **SE 1/4 NW 1/4 SE 1/4 Sec 5, T21S, R3E**
 NM State Plane Coordinates (NAD 83): **167269.44 N 462020.54 E**
 Elevation (Ground Surface): **Below Grade Vault**
 Elevation (Top of Casing): **1373.21 m**
 Drilling Contractor: **Stewart Brothers Drilling Company**
 Driller: **J. Aguilar**
 Total Depth of Borehole (bgs): **1,020' (310.90 m)**
 Borehole Diameter: **17 1/2" 0-115'; reamed 26"; 17 1/2" 115-1,020'**
 Depth to Bedrock (bgs): **Not Reached**
 Depth to Groundwater: **436.64' (133.09 m)[date not recorded]**
 Total Depth Surface Casing (bgs): **115' (35.05 m)**
 Diameter and Type Surface Casing: **19.5" ID; 20" OD Carbon Steel**

Date(s) Well Installed: **6/20/00-6/24/00**
 Date(s) Well Developed: **9/5/00-9/6/00 pumping**
 Field Representative(s): **See Annular Descriptions**
 Total Depth Well Casing (bgs): **996.62' (303.62 m)**
 Type of Casing: **CertainTeed PVC**
 Diameter Well Casing: **7.85" min. ID; 9.05" OD**
 Casing Schedule: **SDR 17**
 Screened Zone (bgs): **418.13-976.67' (127.45-297.69 m)**
 Comments: **Well completed as an injection well below grade in a cement vault**
8/19/00 took preliminary samples to verify well is contaminant-free

Surface Casing	Casing Explanation:	Annular Materials Explanation:	
20" Carbon Steel	Conventional End Cap 9.05" OD CertainTeed PVC	Cement	1/8 Gravel
Conventional Casing 9.05" OD CertainTeed PVC	Bolted Steel Cage Centralizers	Bentonite (Grout Well DF)	4/8 Sand
Conventional Screen 9.05" OD CertainTeed PVC 0.085"-Slot	Water Table	Bentonite Seal	6/9 Sand
		8/12 Sand Bentonite Mix	8/12 Sand
		Slough	8/20 Sand
			10/20 Sand
			16/40 Sand
			20/40 Sand
			30/70 Sand

Feet/Meters

Well Descriptions
All depths listed are bgs (unless noted)

Annular/Borehole Descriptions
All depths listed are bgs

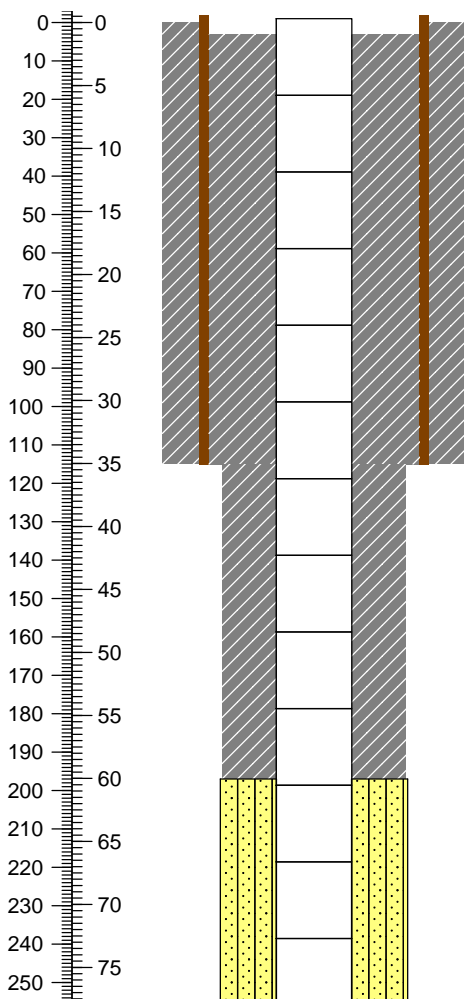

Stick-Up = ~1' (0.3 m) ags installed at installation. Casing was later cut below ground surface as well was completed within a cement well vault.

Surface Casing Stick-Up = 2' (0.61 m) ags at installation. Later cut below ground surface as well was completed within a cement well vault.

20" OD Carbon Steel Surface Casing Depth = 115' (35.05 m)





















Top of Cement Grout (Portland II) = ~3' (0.9 m)

Field Representatives: M. Canavan; G. Giles; L. Hunnicutt-Mack; J. Kirby; J. Pearson; M. Stepro; and R. Weaver

The formation is Santa Fe Group Alluvium from surface to 570' (173.74 m)









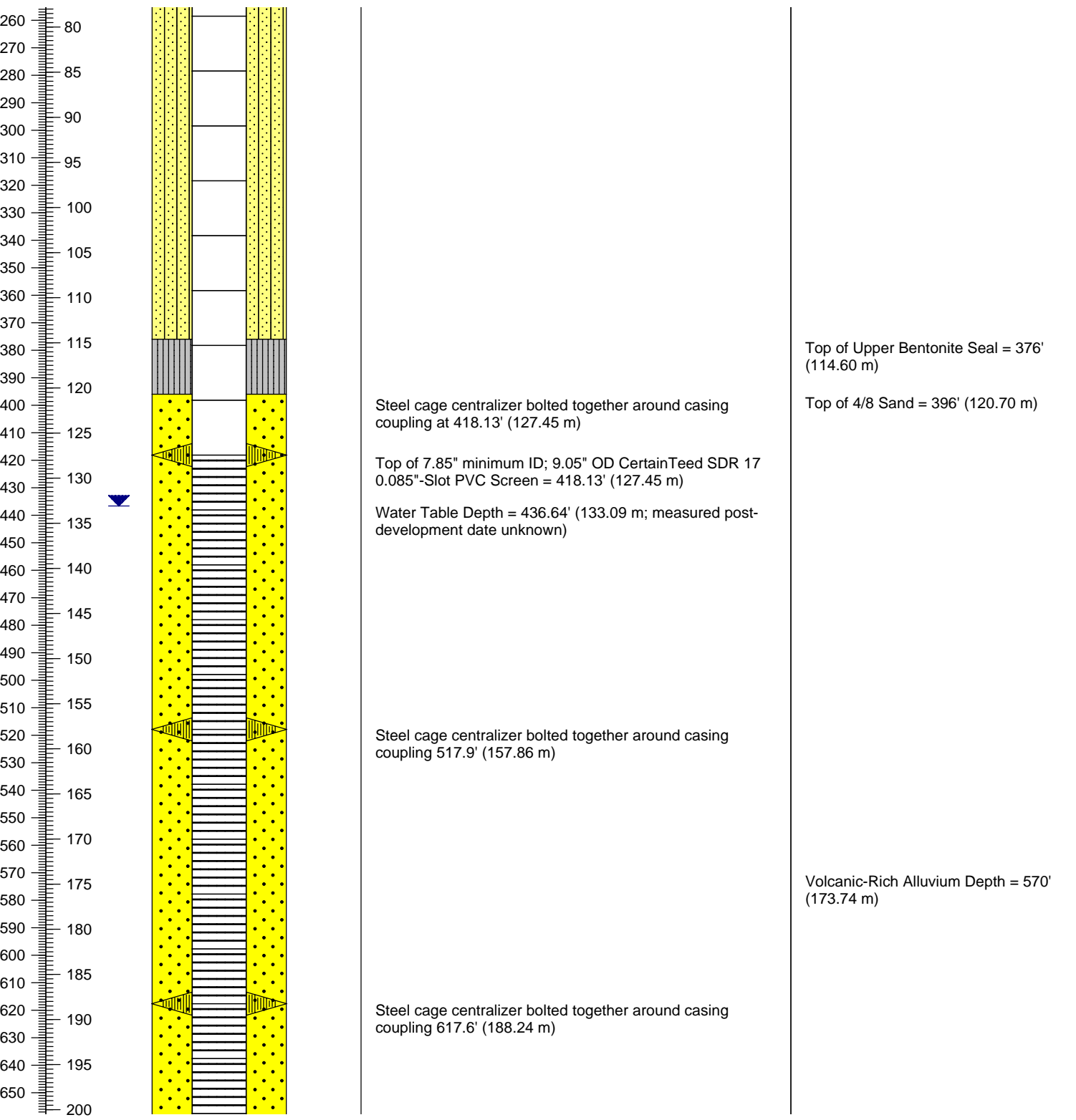











17 1/2" Borehole cemented to 115' (35.05 m)

Top of 8/12 Sand/Bentonite Mix = 197' (60.05 m)

 Surface Casing 20" Carbon Steel	Casing Explanation:	 Cement	Annular Materials Explanation:	
 Conventional Casing 9.05" OD CertainTeed PVC	 Conventional End Cap 9.05" OD CertainTeed PVC	 Bentonite (Grout Well DF)	 1/8 Gravel	 4/8 Sand
 Conventional Screen 9.05" OD CertainTeed PVC 0.085"-Slot	 Bolted Steel Cage Centralizers	 Bentonite Seal	 6/9 Sand	 10/20 Sand
	 Water Table	 8/12 Sand Bentonite Mix	 8/12 Sand	 16/40 Sand
		 Slough	 8/20 Sand	 20/40 Sand
			 30/70 Sand	

Feet/Meters	Well Descriptions All depths listed are bgs (unless noted)	Annular/Borehole Descriptions All depths listed are bgs
--------------------	--	---



 Surface Casing 20" Carbon Steel	Casing Explanation:	 Cement	Annular Materials Explanation:	
 Conventional Casing 9.05" OD CertainTeed PVC	 Conventional End Cap 9.05" OD CertainTeed PVC	 Bentonite (Grout Well DF)	 1/8 Gravel	 4/8 Sand
 Conventional Screen 9.05" OD CertainTeed PVC	 Bolted Steel Cage Centralizers	 Bentonite Seal	 6/9 Sand	 10/20 Sand
 0.085"-Slot	 Water Table	 8/12 Sand Bentonite Mix	 8/12 Sand	 16/40 Sand
		 Slough	 8/20 Sand	 30/70 Sand

Feet/Meters	Well Descriptions All depths listed are bgs (unless noted)	Annular/Borehole Descriptions All depths listed are bgs
--------------------	--	---

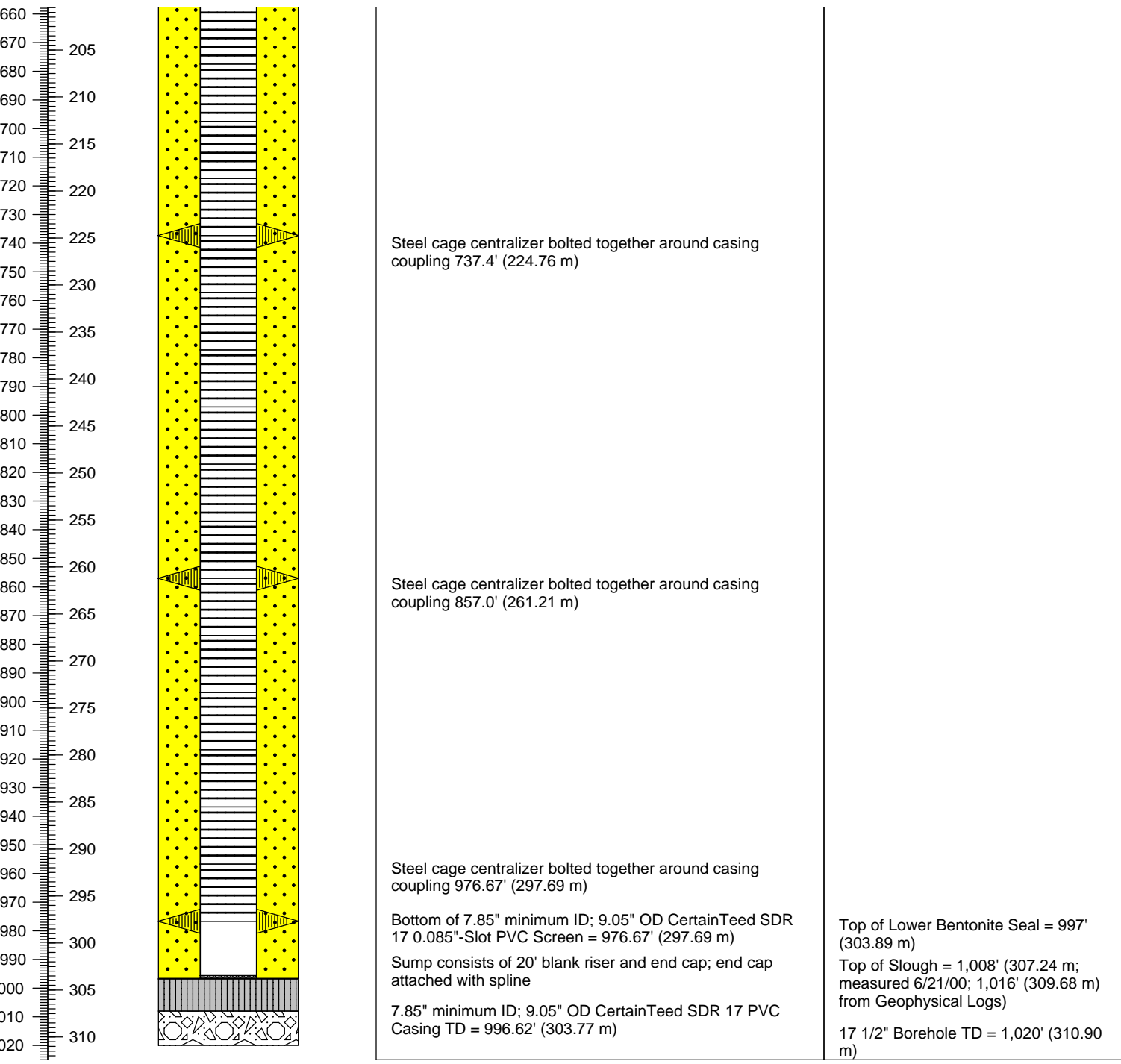

WELL COMPLETION DIAGRAM

INJECTION WELL

Location ID: **PFI-3**

Site ID: **NASA-WSTF, Doña Ana County, NM**

Township and Range: **NW 1/4 SE 1/4 SE 1/4 Sec 5, T21S, R3E**
 NM State Plane Coordinates (NAD 83): **167095.20 N 462179.48 E**
 Elevation (Ground Surface): **Below Grade Vault**
 Elevation (Top of Casing): **1376.17 m**
 Drilling Contractor: **Stewart Brothers Drilling Company**
 Driller: **J. Aguilar**
 Total Depth of Borehole (bgs): **1,020' (310.90 m)**
 Borehole Diameter: **17.5" 0-115' (35.05 m)--reamed 26"; 17.5" 115-1,020'**
 Depth to Bedrock (bgs): **Not Reached**
 Depth to Groundwater: **446.74' (136.17 m)[date not recorded]**
 Total Depth Surface Casing (bgs): **111.5' (33.99 m)**
 Diameter and Type Surface Casing: **19.5" ID; 20" OD Carbon Steel**

Date(s) Well Installed: **5/24/00-5/27/00**
 Date(s) Well Developed: **9/8/00-9/9/00 pumping**
 Field Representative(s): **See Annular Descriptions**
 Total Depth Well Casing (bgs): **996.89' (303.85 m)**
 Type of Casing: **CertainTeed PVC**
 Diameter Well Casing: **7.85" min. ID; 9.05" OD**
 Casing Schedule: **SDR 17**
 Screened Zone (bgs): **417.95 - 976.89' (127.39 - 297.76 m)**
 Comments: **Well completed as an extraction well below grade in a cement vault**
8/23-24/00 took preliminary samples to verify well is contaminant-free

Surface Casing	Casing Explanation:	Annular Materials Explanation:	
20" Carbon Steel	Conventional End Cap 9.05" OD CertainTeed PVC	Cement	1/8 Gravel
Conventional Casing 9.05" OD CertainTeed PVC	Bolted Steel Cage Centralizers	Bentonite (Grout Well DF)	4/8 Sand
Conventional Screen 9.05" OD CertainTeed PVC 0.085"-Slot	Water Table	Bentonite Seal	6/9 Sand
		8/12 Sand	10/20 Sand
		Bentonite Mix	16/40 Sand
		Slough	20/40 Sand
			8/20 Sand
			30/70 Sand

Feet/Meters

Well Descriptions	Annular/Borehole Descriptions
All depths listed are bgs (unless noted)	All depths listed are bgs

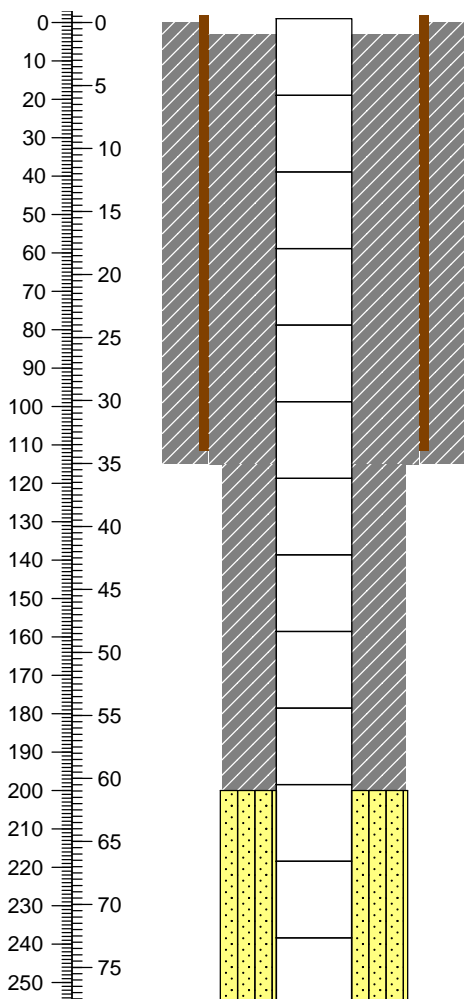

Stick-Up = ~1' (0.3 m) ags installed at installation. Casing was later cut below ground surface as well was completed within a cement well vault.

Surface Casing Stick-Up = 2' (0.6 m) ags at installation. Later cut below ground surface as well was completed within a cement well vault.

20" OD Carbon Steel Surface Casing Depth = 111.5' (33.99 m)

Top of Cement Grout (Portland II) = ~3' (0.9 m)

Field Representatives: M. Canavan; G. Giles; L. Hunnicutt-Mack; J. Pearson; and M. Stepro

The formation is Santa Fe Group Alluvium from surface to 560' (170.69 m)

17 1/2" Borehole cemented to 115' (35.05 m)

Top of 8/12 Sand/Bentonite Mix = 200' (60.96 m)

Surface Casing 20" Carbon Steel	Casing Explanation:	Cement	Annular Materials Explanation:	
Conventional Casing 9.05" OD CertainTeed PVC	Conventional End Cap 9.05" OD CertainTeed PVC	Bentonite (Grout Well DF)	1/8 Gravel	4/8 Sand
Conventional Screen 9.05" OD CertainTeed PVC	Bolted Steel Cage Centralizers	Bentonite Seal	6/9 Sand	10/20 Sand
0.085"-Slot	Water Table	8/12 Sand Bentonite Mix	8/12 Sand	16/40 Sand
		Slough	8/20 Sand	20/40 Sand
			30/70 Sand	

Feet/Meters	Well Descriptions All depths listed are bgs (unless noted)	Annular/Borehole Descriptions All depths listed are bgs
--------------------	--	---

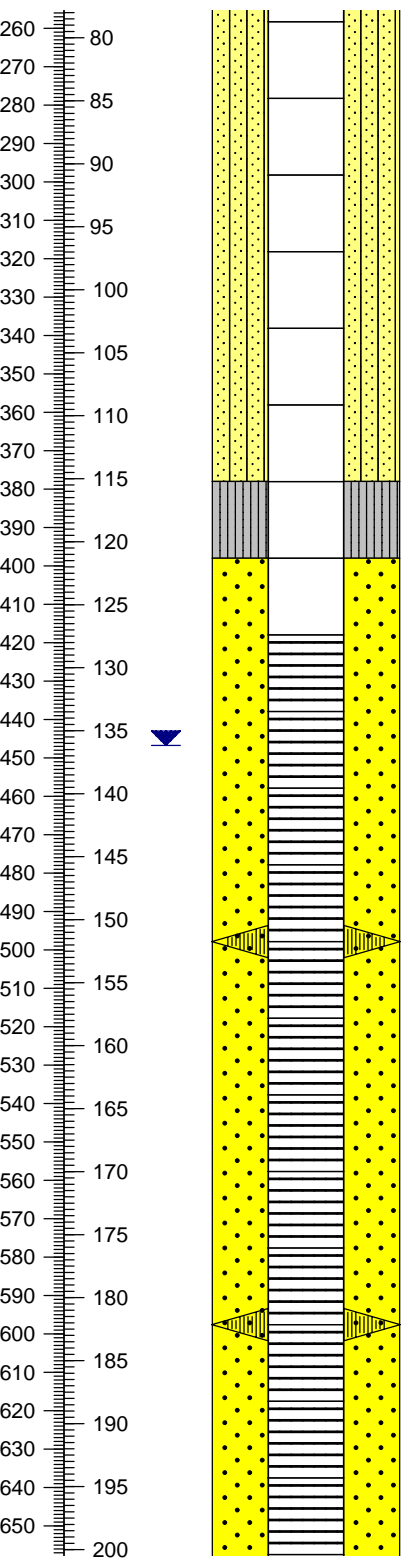

NOTE: Number and locations of centralizers were not recorded at installation. Centralizers assumed to have been installed per the well design.

Top of 7.85" minimum ID; 9.05" OD CertainTeed SDR 17 0.085"-Slot PVC Screen = 417.95' (127.39 m)

Water Table Depth = 446.74' (136.17 m; measured post-development date unknown)

Steel cage centralizer bolted together around casing coupling at 497.8' (151.73 m)

Steel cage centralizer bolted together around casing coupling 597.6' (182.15 m)

Top of Upper Bentonite Seal = 378' (115.21 m)

Top of 4/8 Sand = 398' (121.31 m)

Volcanic-Rich Alluvium Depth = 560' (170.69 m)

<p>Surface Casing 20" Carbon Steel</p> <p>Conventional Casing 9.05" OD CertainTeed PVC</p> <p>Conventional Screen 9.05" OD CertainTeed PVC 0.085"-Slot</p>	<p>Casing Explanation:</p> <p>Conventional End Cap 9.05" OD CertainTeed PVC</p> <p>Bolted Steel Cage Centralizers</p> <p>Water Table</p>	<p>Annular Materials Explanation:</p> <p>Cement</p> <p>Bentonite (Grout Well DF)</p> <p>Bentonite Seal</p> <p>8/12 Sand Bentonite Mix</p> <p>Slough</p> <p>1/8 Gravel</p> <p>4/8 Sand</p> <p>6/9 Sand</p> <p>8/12 Sand</p> <p>8/20 Sand</p> <p>10/20 Sand</p> <p>16/40 Sand</p> <p>20/40 Sand</p> <p>30/70 Sand</p>
--	---	--

Feet/Meters	<p>Well Descriptions All depths listed are bgs (unless noted)</p>	<p>Annular/Borehole Descriptions All depths listed are bgs</p>
-------------	--	---

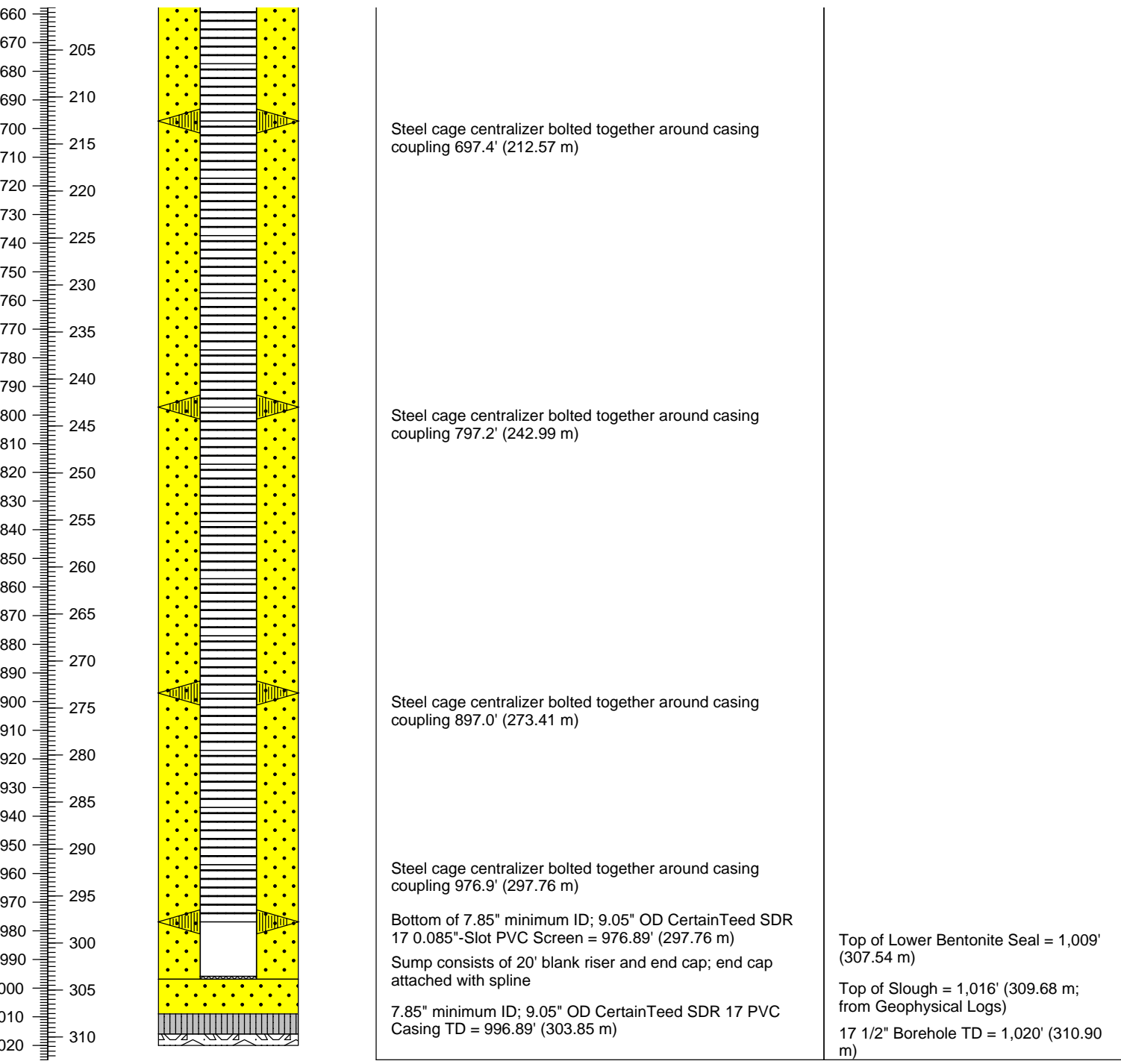

Location ID: **PFI-4**

Site ID: **NASA-WSTF, Doña Ana County, NM**

Township and Range: **SE 1/4, SE 1/4, SE 1/4, Sec 5, T21S, R3E**
 NM State Plane Coordinates (NAD 83): **166966.72 N/462362.43 E**
 Elevation (Ground Surface): **Below Grade Vault**
 Elevation (Top of Casing): **1379.44 m**
 Drilling Contractor: **Stewart Brothers Drilling Company**
 Driller: **Juan Aguilar**
 Total Depth of Borehole (bgs): **911' (277.66 m)**
 Borehole Diameter: **17 1/2" 0-115'; reamed 26"; 17 1/2" 115-911'**
 Depth to Bedrock (bgs): **890' (271.26 m), Rhyolite**
 Depth to Groundwater: **457.86' (139.56 m) [date not recorded]**
 Total Depth Surface Casing (bgs): **115' (35.05 m)**
 Diameter and Type Surface Casing: **19.5" ID; 20" OD Carbon Steel**

Date(s) Well Installed: **7/19/00-7/21/00**
 Date(s) Well Developed: **9/9/00-9/10/00 pumping**
 Field Representative(s): **See Annular Descriptions**
 Total Depth Well Casing (bgs): **897.68' (273.60 m)**
 Type of Casing: **CertainTeed PVC**
 Diameter Well Casing: **7.85" min. ID; 9.05" OD**
 Casing Schedule: **SDR 17**
 Screened Zone (bgs): **397.88-877.75' (121.27-267.53 m)**
 Comments: **Well completed as an injection well below grade in a cement vault**
8/20/00 took preliminary samples to verify well is contaminant-free

Surface Casing	Casing Explanation:	Annular Materials Explanation:	
20" Carbon Steel	Conventional End Cap 9.05" OD CertainTeed PVC	Cement	1/8 Gravel
Conventional Casing 9.05" OD CertainTeed PVC	Bolted Steel Cage Centralizers	Bentonite (Grout Well DF)	4/8 Sand 10/20 Sand
Conventional Screen 9.05" OD CertainTeed PVC 0.085"-Slot	Water Table	Bentonite Seal	6/9 Sand 16/40 Sand
		8/12 Sand Bentonite Mix	8/12 Sand 20/40 Sand
		Slough	8/20 Sand 30/70 Sand

Feet/Meters

Well Descriptions	Annular/Borehole Descriptions
All depths listed are bgs (unless noted)	All depths listed are bgs

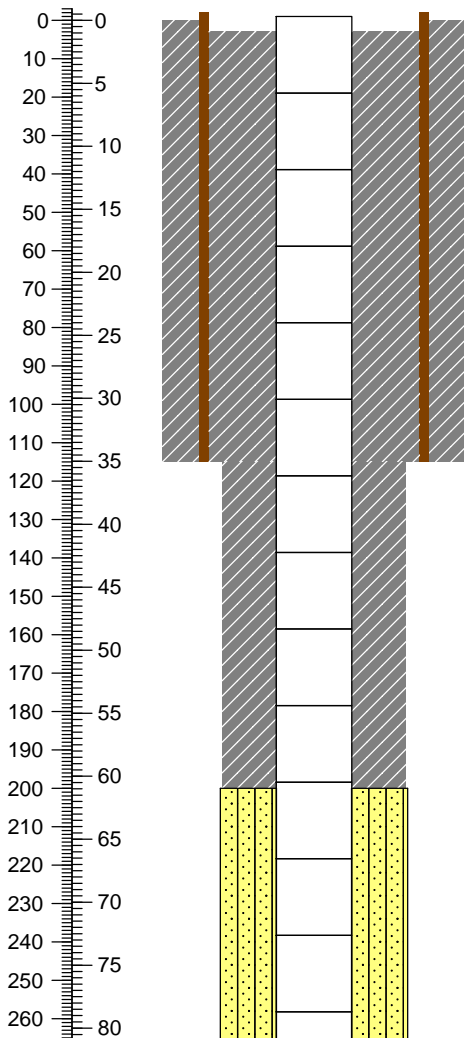

Stick-Up = ~1' (0.3 m) ags installed at installation. Casing was later cut below ground surface as well was completed within a cement well vault.

Surface Casing Stick-Up = 2' (0.6 m) ags at installation. Later cut below ground surface as well was completed within a cement well vault.

20" OD Carbon Steel Surface Casing Depth = 115' (35.05 m)

Top of Cement Grout (Portland II) = ~3' (0.9 m)

Field Representatives: Lela Hunnicutt-Mack; John Pearson; Murray Stepro; and Ron Weaver

The formation is Santa Fe Group Alluvium from surface to 566' (172.51 m)

17 1/2" Borehole cemented to 115' (35.05 m)

Top of 8/12 Sand/Bentonite Mix = 200' (61.96 m)

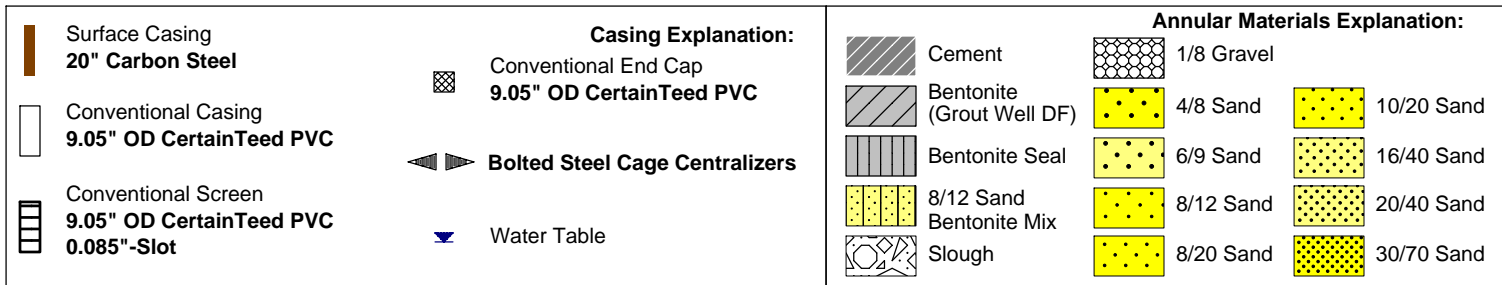

Feet/Meters	Well Descriptions All depths listed are bgs (unless noted)	Annular/Borehole Descriptions All depths listed are bgs
-------------	---	--

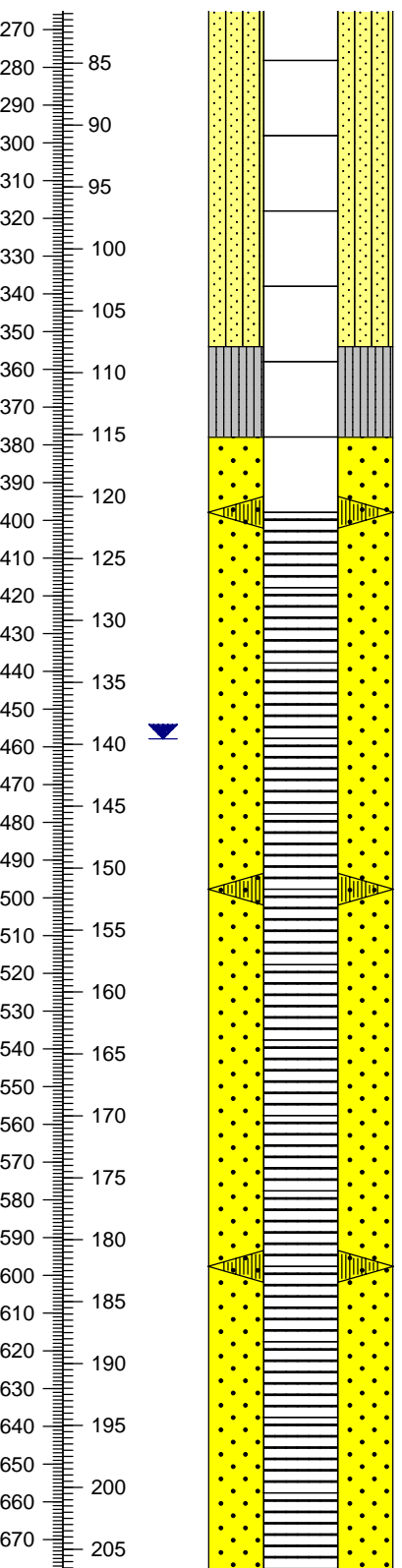

Steel cage centralizer bolted together around casing coupling at 397.88' (121.27 m)

Top of 7.85" minimum ID; 9.05" OD CertainTeed SDR 17 0.085"-Slot PVC Screen = 397.88' (121.27 m)

Water Table Depth = 457.86' (139.56 m; measured post-development date unknown)

Steel cage centralizer bolted together around casing coupling 497.7' (151.7 m)

Steel cage centralizer bolted together around casing coupling 597.63' (182.15 m)

Top of Upper Bentonite Seal = 354' (107.89 m)

Top of 4/8 Sand = 378' (115.21 m)

Volcanic-Rich Alluvium Depth = 566' (172.51 m)

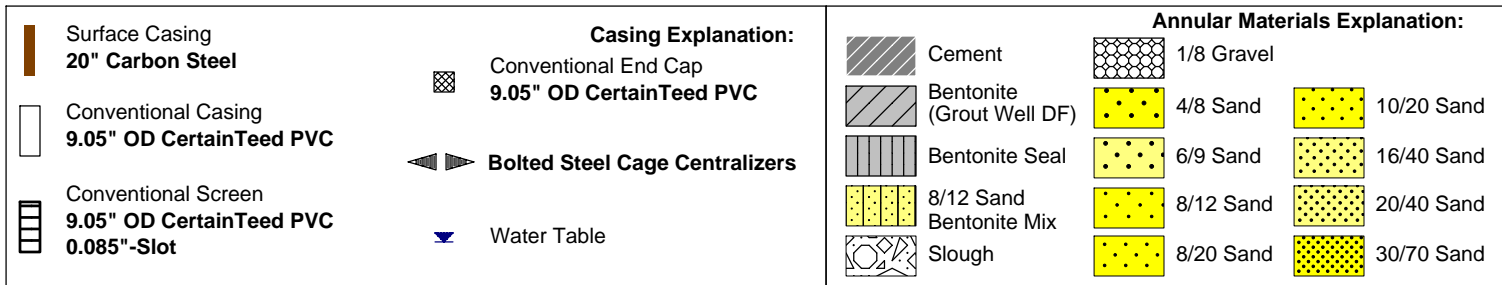

Feet/Meters	Well Descriptions All depths listed are bgs (unless noted)	Annular/Borehole Descriptions All depths listed are bgs
-------------	---	--

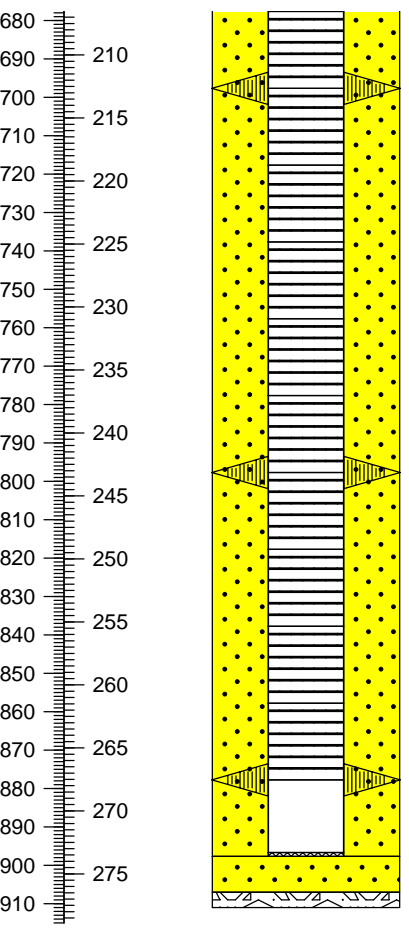

Steel cage centralizer bolted together around casing coupling 697.68' (212.64 m)

Steel cage centralizer bolted together around casing coupling 797.70' (243.13 m)

Steel cage centralizer bolted together around casing coupling 877.75' (267.53 m)

Bottom of 7.85" minimum ID; 9.05" OD CertainTeed SDR 17 0.085"-Slot PVC Screen = 877.75' (267.53 m)

Sump consists of 20' blank riser and end cap; end cap attached with spline

7.85" minimum ID; 9.05" OD CertainTeed SDR 17 PVC Casing TD = 897.68' (273.60 m)

Volcanic Rhyolite Bedrock Depth = 890' (271.26 m)

No Lower Bentonite Seal

Top of Slough = 907' (276.44 m; from Geophysical Logs)

17 1/2" Borehole TD = 911' (277.66 m)

Appendix B PFTS Instrumentation and Control System Features

The control system has the ability to:

- Startup the treatment system in either “auto” or “manual” mode
- Operate the system with any combination of four or more extraction wells online, one or both air strippers in operation, a combination of ten or more UV lamps operating, and any combination of injection wells online
- Shut down an injection well if it detects out-of-tolerance conditions
- Shut down an extraction well if it detects out-of-tolerance conditions
- Shut down the entire system if it detects out-of-tolerance conditions
- Initiate an operator notification if a system shutdown has occurred or if an alarm condition could lead to a system shutdown
- Log system alarms and data to workstation for troubleshooting, historical trending, and preventive maintenance analyses
- Allow system shutdown by an Emergency Stop button
- Allow the operator to initiate a controlled shutdown of the treatment system

The following components are installed as part of the instrumentation and control (I&C) system:

Extraction Wells

- Flow control valves
- Flow meters with automatic Highway Addressable Remote Transducer (HART) flow totalization
- Water-level pressure transducers
- Wellhead pressure transducers
- PLCs
- Power monitors
- Fiber optic cable connection to network
- Motor control centers and submonitors
- Well pumps
- Associated control wiring, hand switches, lights, etc.

Building 650- PFTS facility

- Scale cleaning system control panel
- Scale control system control panel
- Building 650 PLC control panel

- Air stripper #1 PLC control panel and motor controls
- Air stripper #2 PLC control panel and motor controls
- UV reactor PLC control panel and power supply cabinet
- Various Building 650 electrical sensors; sump float switches, compressed air pressure switch
- Cartridge filter pressure switch, pressure transducers, and an automatic cartridge switching system
- Flow meters at air strippers and UV reactor inlets
- Leak detection system control panel
- Leak detection sensors
- Automatic pressure relief valve
- Alarm autodialer
- Building 650 power monitor
- Control station PC, backup PC, and printer
- Wiring and communication links between the control station PC, all PLCs, treatment equipment, leak detection system
- Secure building entry monitoring system
- Associated control wiring, hand switches, indicator lights, etc.

Building 651- Injection Manifold Building

- Building 651 PLC control panel
- PFI well flow meters with automatic HART flow totalization
- Fiber optic cable connection to network
- Associated control wiring, hand switches, indicator lights, etc.

Injection Wells

- Flow meters (backwash flow only) with automatic HART flow totalization
- Injection downhole control valves
- Injection line remote operated valves
- Backwash line remote operated valves
- Water-level transducers
- Well head pressure transducers
- PLCs
- Power monitors
- Fiber optic cable connections to network
- Well pumps and motor controls

- Vault float switches (to shunt trip)
- Associated control wiring, hand switches, lights, etc.

Appendix C PFTS Alarm Conditions

Amber alarm conditions:

- Effluent block valve fails to open
- Effluent block valve fails to close
- Recycle block valve fails to open
- Recycle block valve fails to close
- Spent cleaning solution tank level HI
- Spent cleaning solution tank level HI-HI
- Air stripper flow fails HI or LO
- Air stripper discharge pressure fails HI
- UV inlet pressure fails HI
- UV air pressure fails LO
- UV wiper fault
- UV lamp contactor fault
- UV lamp GFI fault
- UV lamp HI-temp fault
- UV lamp amps fail HI or LO
- UV lamp volts fail LO

Red alarm conditions:

- PFE-X pump failure (two or more extraction wells inoperable)
- Sump level HI (Building 650)
- Pipeline leak detected
- Filter skid pressure HI-HI
- Air stripper fails (commanded on but not operating)
- Air stripper water flow fails HI-HI or LO-LO
- Air stripper water level fails HI or LO
- Air stripper air pressure fails HI or LO
- Air stripper air filter pressure HI
- Moisture detected in UV lamp enclosure
- UV water flow fails LO

- UV water level fails LO
- UV water temp fails HI
- UV not enough lamps on
- UV wiper fault if longer than 24 hours
- UV irradiance LO-LO
- UV inlet pressure HI-HI
- UV lamp enclosure door open
- UV power cabinet temperature fails HI
- UV power cabinet door open
- Building 650 compressed air pressure LO
- PFI flow to grade detected
- PFI backwash flow LO
- PFI backwash valve Fail to Open or Close
- PFI injection valve Fail to Open or Close
- PFI injection valve pressure HI or LO
- PFI GN2 pressure LO
- PFI float switch shunt tripped
- PFI pump Fail to Start or Stop
- PFI well level HI
- PFI well head pressure HI or LO
- PLC communication failure
- HMI emergency stop
- Emergency stop button depressed (outside main entrance to Building 650).
- UV console emergency stop button depressed.

Appendix D MPITS Instrumentation and Control System Features

The MPITS HMI displays information and has the ability to:

- Connect to the network for communication with the PLC
- Start the process input pacing constant for chemical addition
- Place the control of the extraction wells in manual or auto and monitor well level, wellhead pressure, flow, and status, and alarms
- Monitor surge tank level
- Place air stripper filters in manual or auto mode and monitor inlet and outlet pressures and filter status
- Start the air stripper and monitor air flow, sump level
- Place UV filters in manual or auto mode and monitor inlet and outlet pressures and filter status
- Monitor the UV process variables, system status, critical information, and alarms
- Cycle the discharge and recirculation valves, and monitor status

The MPITS PLC has the ability to:

- Connects to the network for communication with the HMI
- Provide the logic control to start the process within operating parameters, alarm, and output signal to chemical feed pump
- Provide the logic to control the extraction wells and receive information on level, well head pressure, flow, status, and alarm
- Receive information from the surge tank level sensors and alarm and provide information to control the extraction well pumps
- Provide the logic to control the air stripper filter auto change over, receive inlet and outlet pressure information, and alarm
- Provide the logic to start the air stripper, receive information from pressure switches, air flow meters, level transducer and motor status
- Provide the logic to control the UV filter auto change over, receive inlet and outlet pressure information, and alarm
- Provide the logic to shut down the MPITS process when major and critical alarms have been received and alarm
- Provide the logic to place the effluent valves in either discharge or recirculation position.
- Send signals to the Auto Dialer

The following components are installed as part of the instrumentation and control (I&C) system:

Extraction Well Enclosures

- Flow meters
- Well head pressure transducers
- Water level transducers
- Leak detection system
- Shunt trip
- Combination starter with auxiliary contacts.

Building 655- PFTS facility

- Network hub
- Transient voltage surge suppressor
- Shunt trip circuit
- Autodialer
- Influent flow meter
- Chemical metering pump
- Surge tank level transducer, high level switch, and low-level switch
- Air stripper inlet and outlet pressure transducer, inlet valve position indicator, and flow
- Air stripper air inlet flow transducer, air sump high- and low-pressure switch, sump level transducer
- UV air filter inlet and outlet pressure transducers and inlet valve position indicator
- UV system
 - Flow meter
 - Transmissivity analyzer
 - Reactor water level switch
 - Reactor water temperature switch
 - Reactor irradiance transmitter
 - Power monitor
 - PLC
 - HMI
 - Power distribution center

Infiltration Basin

- Flow meter
- Altitude control valve

Appendix E MPITS Alarm Conditions

The list of treatment alarms that force the UV system to increase UV intensity to 100% are identified as “Major” alarms and provided below.

- UV Transmittance Low
- System UV Transmittance Meter Faulted (Optiview)
- System UV Transmittance Analog Signal Fault
- Water Temperature Low
- Water Temperature High
- System Inlet Water Temperature Analog Signal Fault
- Train UV Dose Low
- Train Power Level Low
- Train UV Log Reduction Low Train UV
- Train Water Flow Low
- Train Water Flow High
- Train Water Flow Meter Analog Signal Fault
- Rector communications control board A Communications Lost Fault Present
- Reactor Low UV Intensity
- Reactor Multiple Lamp Failure (NOT Broken Lamp)
- UV Log Reduction Low

The list of “Critical” treatment shutdown alarms (UV and process) includes:

- Air Stripper Air Pressure Low
- UV Pump1 Failed To Stop
- UV Pump2 Failed To Stop
- UV Broken Lamp
- Train Water Level
- Reactor Multiple Lamp Failure
- Reactor Wiper Fault
- Reactor communications control board A Communications Lost Fault Present
- UV Log Reduction Low Critical Alarm
- UV System Critical Alarm

- UV Train Critical Alarm
- System PLC Faulted Major Fault Detected
- System input/output Module Fault Present

The List of critical safety related shutdowns includes:

- B655 Sump High-High Level
- Control Room Emergency Stop Button
- East Exterior Door Emergency Push Button
- Fire Flow Alarm
- B655 Power Loss, Power Imbalance, and Loss of phase 7