

Process Specification for the Manual Arc Welding of Titanium Alloy Hardware

Engineering Directorate

Structural Engineering Division

May 2020



National Aeronautics and
Space Administration

Lyndon B. Johnson Space Center
Houston, Texas

Verify correct version before use.

Process Specification for the Manual Arc Welding of Titanium Alloy Hardware

Prepared by:	Signature on File Daniel J. Rybicki Division/NT4 Materials and Processes Branch/ES4	05/26/2020 Date
Reviewed by:	Signature on File John D. Figert Materials and Processes Branch/ES4	05/26/2020 Date
Reviewed by:	Signature on File Clinton S. Denny Quality and Flight Equipment Division/NT4	05/26/2020 Date
Approved by:	Signature on File Brian Mayeaux Materials and Processes Branch/ES4	05/26/2020 Date

Verify correct version before use.

REVISIONS		
VERSION	DESCRIPTION	DATE
--	Original version	6/1/95
A	Formatting, changed process owner, rewrite numerous sections for clarification, deleted requirement for WIR, deleted section 8.2 on audits, added section 8.3 on WPQ, deleted mil specs for NDE, added PRCs for NDE.	07/07/99
B	Comprehensive rewrite to combine PRC-0002 and PRC-0004 and make editorial changes. PRC-0004 will be cancelled with this change. Include requirements for precision cleaned hardware (ref. JPG 5332.1).	12/30/2003
C	Updated the review and approval signature blocks; added definitions of flight and non-flight hardware in 2.0; added NAS 410, NASA-STD-5009, PRC-5010, PRC-6510 and AWS G2.4 to 4.0; deleted PRC-6504 from 4.0; revised 6.5 to allow mechanical repairs and restrict welded repairs to one attempt; revised 7.0 through 7.3 to add separate inspection requirements for flight hardware and require NAS 410 certification for NDE personnel inspecting flight hardware; revised the WPS, PQR and WPQ requirements in 8.0 to include a provision found in 6.1.1; and revised Appendix A in its entirety.	10/10/2012
D	Rewrite numerous sections for clarification, added Appendix B (hardware classifications), modified Class B and C weld definitions, added JPG 8500 to references, removed PRC-0008 and TI-0000-01 from references, rewrote section 5.0, added more emphasis on using ELI grade filler metals, require MTR for filler procurement, restructured list in section 6.6, added definitions as section 10.0, align format and content with PRC-0015.	05/15/2020

Verify correct version before use.

1.0 SCOPE

This process specification provides the minimum requirements that govern the manual arc welding of titanium alloy flight and non-flight hardware. Procedural and quality assurance requirements are given. All work instructions and Welding Procedure Specifications (WPS) used during welding shall satisfy the requirements of this process specification and its applicable documents.

2.0 APPLICABILITY

This process specification applies to arc welding of titanium and titanium alloy hardware that is fabricated under the authority of NASA/Johnson Space Center (JSC) by the following welding process: Gas Tungsten Arc Welding (GTAW) and Plasma Arc Welding (PAW).

The Gas Metal Arc Welding (GMAW) process is not considered an acceptable process for welding titanium alloys under this process specification.

3.0 USAGE

This process specification shall be called out on the engineering drawing by a drawing note with the following format (example shown) which specifies the PRC and weld class nomenclature:

WELD AND INSPECT PER NASA/JSC PRC-0002, CLASS A

To minimize fabrication costs by avoiding over-inspection and unnecessary rework/repair, individual welds, or components on a weldment shall be classified separate where possible. This can be accomplished by including a note on the engineering drawing with the general format shown below which specifies only the PRC nomenclature. The weld class shall then be indicated by either: 1) calling out the specific weld class with the welding symbol at the individual weld joints or, 2) by using specific flag notes with the welding symbol at the individual weld joints. Refer to Figure 3.0a and 3.0b below for examples of these methods.

WELD AND INSPECT PER NASA/JSC PRC-0002. WELD CLASSES SHALL BE AS INDICATED AT WELD LOCATION CALLOUTS.

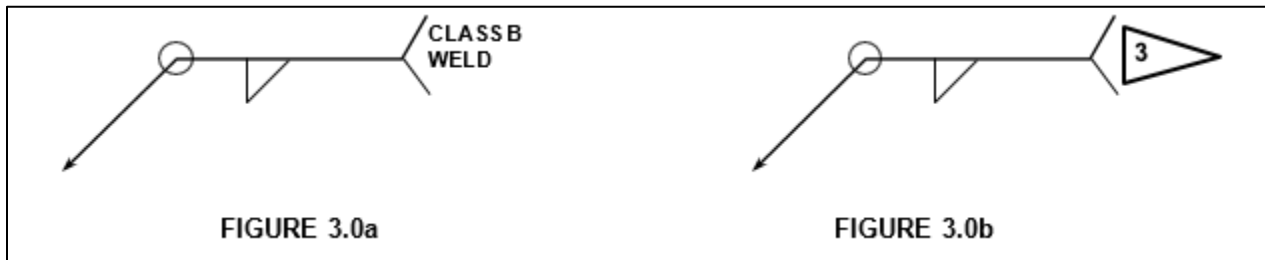

3.1 WELDING CLASSES

Welds made using this specification shall be primarily classified in accordance with the service conditions of the weldment. Therefore, the "Class" defines the severity

Verify correct version before use.

of service intended for the joint by design and governs the extent to which quality assurance provisions are applied to the weld joint as specified herein.

Alternatively, individual welds, welded connections, or entire weldments may be classified by relating the weld to the factor of safety used in the design. However, when classifying welds in this manner, regardless of the factor of safety, adequate consideration should be given to the severity of the service condition (e.g., static loading vs. dynamic loading, cyclic, vibration, fatigue, corrosive, extreme temp, etc.), material characteristics (e.g., ductility, toughness, etc.), and the potential consequences of weld failure.

Where conditions exist that make it difficult to choose between two weld classes, the more stringent of the two classes shall then be applied.

Quality assurance provisions for all weld classes are detailed in Section 7.0. Weld classes shall be chosen on the basis of the following definitions:

- a. Class A — Applies to welds in critical load bearing elements that are not fail- safe. Class A welds are typically used in primary load bearing connections. Failure of a Class A weld in service is expected to be catastrophic and would likely result in the loss of life, system(s), control, or major components. Alternatively, if it is determined from appropriate engineering analyses that a weld has a Factor of Safety (FS_{uts}) vs ultimate tensile strength of the calculated minimum weld throat cross section of <2.0 , it shall be designated as a Class A weld.
- b. Class B — Applies to welds in load bearing elements that are fail-safe. Class B welds are typically used in secondary load bearing (i.e., shared load) connections. Failure of a Class B weld in service is expected to be serious and would likely reduce the overall efficiency of the system, but the loss of a system(s) or major components or endangerment to personnel is not expected. Alternatively, if it is determined from appropriate engineering analyses that a weld will have a FS_{uts} of ≥ 2.0 and <3.5 , it may be designated as a Class B weld.
- c. Class C — Applies to welds that are in minor load bearing elements that are fully contained where failure in service is expected to have minor or no effect on the efficiency of a system and endangerment to personnel would not occur. Class C welds are typically used in secondary or tertiary load bearing (i.e., shared load) connections. Alternatively, if it is determined from appropriate engineering analyses that a weld will have a FS_{uts} of ≥ 3.5 , it may be designated as a Class C weld.

In addition to the above weld class definitions, the following requirements shall also apply to weld classifications:

- If any weld intersects or overlaps another weld of a higher classification, then the lower classed weld shall be automatically upgraded to the higher of the 2 weld classes and subjected to the appropriate quality assurance provisions.
- If any weld falls within $\frac{1}{2}$ " of any higher classed weld, then it shall be

Verify correct version before use.

automatically upgraded to the higher of the 2 weld classes and subjected to the appropriate quality assurance provisions.

3.2 WORK INSTRUCTIONS

Work instructions shall be used for implementing this process specification. The work instructions shall contain enough detail to ensure that the manufacturing process produces consistent, repeatable results that comply with this specification. At JSC, these work instructions are approved as Detailed Process Instructions (DPIs) that describe in a detailed, step-by-step format the required procedures, equipment, and materials to be used for conducting a given process. If this manufacturing process is to be performed by an outside vendor, work instruction development shall be the responsibility of the vendor.

3.3 DESIGN REQUIREMENTS

- a. The design of welded joints (including weld sizes) shall utilize adequate engineering analysis methods (e.g., stress analysis, fracture mechanics/fracture control, finite element analysis, failure mode and effects analysis, etc.) to ensure that the resultant connection strength is capable of successfully transferring the maximum load expected to pass between the interconnecting members and meet the required factors of safety and design margins.
- b. All engineering drawings shall depict welded joints using the applicable symbols described in AWS A2.4.
- c. The engineering drawing shall specify any additional or alternate testing or inspection requirements. Where spot, intermittent, or other special inspection requirements are specified that deviate from those stated herein, it shall be detailed on the drawing as a note or by using the applicable symbology described in AWS A2.4. For Class A welds, alternate or reduced NDE requirements shall not be allowed.
- d. Class A welds are expected to be welds requiring full strength of the weld joint therefore, these welds shall be a groove design and full penetration wherever possible. The ability to successfully perform radiographic examination (RT) on these weld joints shall be considered during design.
- e. Except for titanium alloy 6Al-4V welded with 6Al-4V filler metal, hardware will be delivered in the “as welded” condition unless otherwise specified on the engineering drawing. If required, the engineering drawing shall include notation that will specify an appropriate heat treatment process, referencing SAE AMS-H- 81200. For welds in alloy 6Al-4V welded with 6Al-4V filler metal, a stress relief heat treatment at 1100° F for 2 hours (vacuum or inert gas atmosphere) shall be required.
- f. Intermittent welding (skip welds) shall not be allowed for Class A joints.
- g. Intermittent welds shall not be allowed for butt welds (square or groove design) unless the unwelded portions of the joint are adequately

Verify correct version before use.

supported to prevent one member from coming out plane with the adjoining member.

- h. Weld filler material shall be specified on the engineering drawing in the parts list.

4.0 REFERENCES

The standards listed below shall be considered a part of this specification to the extent specified herein. Unless otherwise indicated, the revision that is in effect on the date of invitation for bids or the date of request for proposals shall apply.

a. Aerospace Industries Association of America (AIA) National Aerospace Standards (NAS)

NAS 410 *NAS Certification & Qualification of Nondestructive Test Personnel*

b. American Society of Nondestructive Testing (ASNT)

SNT-TC-1A *Personnel Qualification and Certification in Nondestructive Testing*

c. American Welding Society (AWS) Standards

ANSI/AWS A2.4 *Standard Symbols for Welding, Brazing and Nondestructive Testing*

ANSI/AWS A3.0 *Standard Welding Terms and Definitions*

ANSI/AWS A5.12 *Specification for Tungsten Arc Welding Electrodes*

ANSI/AWS A5.16 *Specification for Titanium & Titanium Alloy Welding*

Electrodes & Rods ANSI/AWS B2.1 *Standard for Welding Procedure and*

Performance Qualification ANSI/AWS D1.9 *Structural Welding Code – Titanium*

ANSI/AWS G2.4 *Guide for the Fusion Welding of Titanium and Titanium Alloys*

ANSI/AWS QC-1 *Standard for AWS Certification of Welding Inspectors*

d. Compressed Gas Association, Inc. (CGA)

CGA G-11.1 *Argon, Commodity Specification for*

e. Federal Documents

BB-H-1168 *Helium Federal Specification*

Verify correct version before use.

f. Military Documents

- MIL-A-18455 *Argon, Technical*
 MIL-P-27407 *Propellant Pressurizing Agent, Helium*

g. NASA/JSC Documents

- JPG 5322.1 *Contamination Control Requirements Manual*
 JPG 8500.4 *Engineering Drawing System Manual Drawing Format, Requirements, and Procedures*
 PRC-5010 *Process Specification for Pickling, Etching and Descaling of Metals*
 PRC-6503 *Process Specification for Radiographic Inspection*
 PRC-6506 *Process Specification for Liquid Penetrant Inspection*
 PRC-6510 *Process Specification for Ultrasonic Inspection of Welds*
 SOP-004.5 *Control of Weld and Braze Filler Materials, Electrodes, and Fluxing Materials*
 SOP-007.1 *Preparation and Revision of Process Specifications*

h. NASA Headquarters

- NASA-SPEC-5004 *Welding of Aerospace Ground Support Equipment and Related Nonconventional Facilities*
 NASA-STD-5006 *General Fusion Welding Requirements for Aerospace Materials Used in Flight Hardware*
 NASA-STD-5009 *Nondestructive Evaluation Requirements for Fracture Critical Metallic Components*

i. SAE – Aerospace Material Specification (AMS)

- SAE AMS-H-81200 *Heat Treatment of Titanium and Titanium Alloys*

5.0 MATERIAL REQUIREMENTS

All base materials used in the welding of hardware per this process specification, shall meet the requirements of an applicable commercial specification (e.g., AMS, ASTM, etc.). Alternatively, a manufacturer's specification may be used but it must be approved by the responsible materials and processes (M&P) organization. Filler and electrode materials used shall conform to the applicable American Welding Society (AWS) specification. Filler metals shall be extra low interstitial (ELI) grade wherever possible. Interstitial elements include but are not limited to, oxygen,

Verify correct version before use.

hydrogen, and nitrogen. Filler metals and electrodes purchased to alternate specifications shall be allowed provided they meet the minimum requirements of the specifications listed herein.

5.1 SHIELDING GASES

Allowable shielding gases (including purge gases) are listed in Table I. Gases purchased to alternate specifications shall be allowed provided they meet the minimum requirements of the specifications listed herein. Mixtures of these gases are allowed, and the nominal mixture used for the qualification welding shall be that used for production and shall be listed on the WPS. All shielding and purging gases and nominal gas mixtures shall be treated as an essential procedure qualification variable and shall be subject to the AWS B2.1 requirement for these variables. In addition:

- a. All gases used for welding and purging shall be delivered through clean, non- volatile residue (NVR) tubing with known low permeability (e.g. stainless steel, polyethylene).
- b. Nitrogen, oxygen, carbon dioxide, or hydrogen gas in any concentration, shall not be used for shielding or purging in any welding operation governed under this specification.
- c. All gases used for shielding or purging shall have a dew point of -60°F (-51 °C) or better and oxygen content shall not exceed 50 ppm.

Table I. Allowable Shielding Gases

GAS	DESCRIPTION	SPECIFICATION
Argon	Gas	MIL-A-18455
Argon	Type II, Grade B (Liquefied)	CGA G-11.1
Helium	Type I, Grade A	MIL-P-27407
Helium	Grade A	BB-H-1168

5.1.1 Weld Atmosphere

A protective weld atmosphere shall be freely accessible to all portions of the joint. The weld atmosphere for inert gas chambers, and gas supplies for trailing shields shall be monitored for moisture or oxygen content. Dew points shall be -60°F (-51 °C) or better and O2 content shall not be greater than 50ppm. All gas shielding must be checked to ensure that a positive flow exists all times, so that a stagnant atmosphere does not exist during welding or when the base metal is at an elevated temperature. Shielding and purging flows shall not be disengaged until the substrate is below 600°F (~316°C).

5.1.2 Weld Atmosphere Purity Test

Verify correct version before use.

Atmospheric purity shall be verified by making an autogenous fusion pass on a commercially pure (CP) titanium strip, which has been properly cleaned. A fusion zone and heat affected zone with a bright silver or light straw color is acceptable (condition #1 or #2 below). No tacking or welding shall be performed on production hardware until an acceptable color has been obtained. Weld discoloration condition in increasing order of contamination is:

1. bright silver - acceptable
2. light straw - acceptable
3. dark straw - **unacceptable**
4. purple - **unacceptable**
5. any shade of blue - **unacceptable**
6. yellow – **unacceptable**
7. grey - **unacceptable**
8. white (may have loose powder) – **unacceptable**
9. brushed – **unacceptable** (welds that have been brushed before inspection are can be rejected, regardless of color before brushing)

5.2 FILLER METALS AND ELECTRODES

Filler metals shall be selected based on specific base metals being welded, service conditions, design requirements (load conditions, etc.), and other design or service factors. The specific selection must be approved by the responsible M&P organization prior to use. In addition, the following shall apply:

- a) Filler and electrode materials used shall conform to the applicable AWS specifications listed herein. Filler metals and electrodes purchased to alternate specifications shall be allowed provided they meet the minimum requirements of the specifications listed herein. Filler metals shall be procured with delivery of a valid material test report (MTR).
- b) Filler metals shall be manufactured by a high-quality (HQ) method involving multiple melt cycles. In addition, the final melt cycle shall be made under vacuum.
- c) Wherever possible, filler metals designated as extra-low interstitial (ELI), should be used.
- d) Where the end product is to be used in a cryogenic application, then ELI filler metals shall be used.
- e) Weld filler metals shall be called out on the engineering drawing in the parts list.
- f) Non consumable tungsten and tungsten alloy electrodes for GTAW and PAW shall be selected according to the process being used at the direction of the responsible M&P organization. The electrode type and size shall be specified on the WPS.

5.2.1 Control and Storage

Verify correct version before use.

Welding electrodes and filler metals shall be stored in a clean, dry, and controlled area that provides protection from contamination, physical damage, commingling of alloys and loss of identification/traceability. Any form of electrodes or weld filler metal which is damaged, dirty, exhibits oxidation/corrosion or has been contaminated with water, oil, grease or any form of hydrocarbons shall not be used and shall be disposed of in accordance with an appropriate disposal procedure. For JSC operations, welding electrodes and filler materials shall be controlled in accordance with SOP-004.5. Outside vendors shall provide control and storage according to the applicable material specification or manufacturer's recommendation, whichever is more rigid.

5.3 MECHANICAL PROPERTIES

Unless otherwise specified, minimum mechanical properties that determine an acceptable weld qualification for titanium alloys shall be that as specified in AWS B2.1. In addition, when qualifying a WPS using a titanium alloy not listed in AWS B2.1 the diameter of the plunger (dimension "A" in Annex II of AWS B2.1) used for the guided bend test shall not exceed 20T (10T radius). For the alloys listed in Appendix C, use the bend radiuses shown in the table.

5.4 Welding Chambers and Trailing Gas Shielding

When an inert gas or vacuum chamber is used for welding or trailing torch shields and/or a trailing or fixed gas purge assemblies are used, the specific equipment and method shall be considered an essential variable during qualification of the WPS and personnel qualifications.

6.0 PROCESS REQUIREMENTS

All weldments shall be fabricated according to the requirements of this process specification and shall be performed using Welding Procedure Specifications (WPS) that have been qualified in accordance with the requirements of Section 8.0 in addition to that as detailed below. In addition, when qualifying a WPS for titanium welding, the welding setup shall be considered an essential variable.

6.1 REQUIREMENTS FOR ALL PROCESSES

6.1.1 Pre-weld Cleaning of Weld Joint Surfaces

Prior to welding, all weld joint surfaces within a minimum of ½" of the weld line shall be cleaned in a manner shown to be adequate and repeatable in producing a surface cleanliness level conducive to producing sound welds by a given weld process. The specific process and procedural steps to carry out the process shall be part of the procedure qualification activities and shall be appropriately detailed on the qualification and procedure specification (PQR and WPS) documentation as well in the production work instructions. Personnel shall be trained in these same methods and process techniques.

6.1.2 Intermittent Welding

Applicable to all processes, unless otherwise specified, weld joints that are specified

Verify correct version before use.

for intermittent welding shall have the ends of the parts, or departure from a straight weld line (e.g., square corner, etc.), welded regardless of the interval of the weld.

6.1.3 Tooling and Fixturing

Weldments shall be fixtured with appropriate tooling as deemed necessary by the fabricator. Tools and fixtures shall be constructed of materials that will not interfere with the welding process nor damage or contaminate the hardware.

6.1.4 Temporary or Tack Welding

Temporary (includes the term “tack” welding) welding in areas of the hardware not planned for welding or where the temporary weld will not be totally consumed by the final weld, shall not be allowed. All temporary welds placed at or in a weld joint shall be ground or feathered by welding appropriately to accommodate the final welding process to achieve the expected deposit of sound weld metal. All temporary and tack welding shall only be performed by a welder(s) whose qualifications are current and applicable.

6.1.5 Welding Equipment

Equipment (e.g., power supplies, positioners, flowmeters, etc.) used for manual welding operations need not have calibrated instrumentation (dials, gauges, indicators, meters, etc.). However, reference indicating instrumentation (e.g., dials, meters, gauges, etc.) shall be fully functional (i.e., useful output) and in good working order. The equipment shall be capable of being used by a qualified welder, using a qualified procedure, to produce sound and contaminant free welds. At the discretion of the responsible M&P organization, specific equipment instrumentation and metering devices may be calibrated to ensure repeatability of the process.

6.1.6 Welding Precision Cleaned Hardware (including tube preparation for welding)

Operators must maintain cleanliness for precision-cleaned hardware during welding into an assembly. The welding operation shall be performed in a dedicated Class 100,000 clean work area. This may require temporary tents over the weld area and/or local monitors located in the area of welding to ensure the Class 100,000 environment is being met. Portable particle counters shall be located as close as possible to the work area, so as to monitor local contaminants during tube preparation and welding. All tools used in weld preparation shall be cleaned to the visibly clean (VC) level per JPG 5322.1 and maintained clean (e.g. bagged in VC clean bags when not in use).

Hardware that cannot be subsequently precision-cleaned shall implement an approved method for protecting against system contamination during tube preparation and welding. Consult the responsible M&P organization for approval prior to welding. The installation and removal of physical barriers (e.g., plugs, etc.) shall be tracked by a reliable method and independently verified. Exposed internal surfaces of the tube shall be cleaned using a swab wetted with an approved solvent. A positive backpressure shall be maintained as the plug is removed. Abrasives including sandpaper or abrasive pads inside tubes or on unprotected surfaces shall not be allowed.

Verify correct version before use.

Tube cutters shall use a sharp blade, changed frequently. Cutting shall be performed with minimal cutter pressure to aid in preventing particle generation. Tube facing operations shall use vacuum to remove particulate. Facing operations shall be performed away from the weld assembly area, to reduce particulate contamination of the welding work area. Tube facing shall be performed without the use of cutting oils, other fluids, lubricants or coolants. Abrasives, including sandpaper or abrasive pads, shall not be used inside tubes or when unprotected internal surfaces are exposed. After each tube preparation, and prior to welding, a high-velocity gas purge shall be performed. The purge gas velocity shall be the maximum attainable using a 90-psig (minimum) source. The purge gas used during facing and welding shall meet the hydrocarbon and particulate requirements for the system under assembly. The purge gas shall be supplied in accordance with Section 5.1.

6.2 PROCESS SPECIFIC REQUIREMENTS

6.2.1 Gas Tungsten Arc Welding

Additional filler metal shall be used with the GTAW process unless it can be demonstrated by weld qualification that weld cracking and other undesirable metallurgical conditions will not exist in the finished weld made without filler metal (autogenous weld). This method of welding shall be specified on an approved WPS.

6.2.2 Plasma Arc Welding

Additional filler metal shall be used with the PAW process unless it can be demonstrated by weld qualification that weld cracking and other undesirable metallurgical conditions will not exist in the finished weld made without filler metal (autogenous weld). This method of welding shall be specified on an approved WPS.

6.2 PREHEATING

Preheat shall not exceed 600°F (~316°C) and shall be specified on the WPS. Actual welding shall begin immediately after preheating has reached the temperature specified on the WPS. Temperature indicating crayons (markers) shall not be used to measure base or weld metal temperature.

6.3 INTERPASS TEMPERATURE

- a. In weld joints between different base metal types and thickness, the higher of the preheat requirements of the joint members shall apply.
- b. Minimum interpass temperature during welding shall be the same as the maximum preheat temperature specified in the welding procedure specification and shall be maintained by the application of concurrent heat, if necessary.

6.4 POST-WELD HEAT TREATMENT (PWHT)

Post-weld heat treatment shall be applied only when specified by the engineering drawing and/or WPS and shall be performed after completion of welding. All PWHT shall be performed according to SAE AMS-H-81200. Vibratory techniques shall not

Verify correct version before use.

be used in place of thermal treatment. All weld inspections shall be applied as soon as practical following all post weld heat treatment activities.

6.5 WELD REPAIRS AND WELDED REPAIRS TO BASE METAL

Two attempts shall be allowed to make a weld repair. If after the second attempt a defect still exists, the condition shall be documented on an appropriate non-conformance report (NCR) or discrepancy report (DR) form. All repair and rework shall be performed using the WPS used for the original weld, a specific qualified WPS for that repair. Rework and repairs shall meet all of the requirements of the original drawing and any additional requirements documented in the WPS. Weld rework and repair does not include the correction of dimensional or other deficiencies of the groove/bevel preparation of weld joints by “buttering” or build up provided the area corrected by welding is fully consumed in the final weld. Also, the following requirements shall apply in the weld repair activity:

- a. Mechanical Repairs. Defects shall be repaired by routing or machining the weld metal to the extent needed to completely remove the defects. Thermal gouging and cutting shall not be used. For groove welds, the reinforcement shall not be machined past flush to the base metal. For fillet welds, the final machined weld profile shall meet the applicable profile and size requirements. In both cases, the repair shall be blended smoothly into the unrepaired weld metal. All repairs shall be subjected to the same visual, surface and subsurface inspections as the unrepaired weld. Repairs requiring liquid penetrant inspection shall be etched in accordance with PRC-5010 prior to inspection.
- b. Weld Repairs. Defects shall be repaired by routing or machining the weld metal to the extent needed to completely remove the defects. Thermal gouging and cutting shall not be used. The final repair cavity shall be of a configuration suitable for welding. Prior to welding, the excavation shall be subjected to the same visual, surface and subsurface inspections as the unrepaired weld. Excavations requiring liquid penetrant inspection shall be etched in accordance with PRC-5010 prior to inspection. Weld repairs shall be documented by the use of a weldment map or other record with sufficient detail to ensure identification of the weldment, identification of repair location(s), and type of defect. Repair welds shall be subjected to the same visual, surface and subsurface inspections as the unrepaired weld.
- c. Straightening. Welds or adjacent base metal which have been deformed by the welding operation may be straightened using a fixture during a controlled stress relief or anneal operation. Prior to any straightening operation(s) taking place the responsible M&P organization shall be consulted. All straightening operations shall be performed prior to any final inspection.
- d. Base Metal Repairs. Repairs to base metal anomalies shall be brought to the attention of the responsible M&P organization for consideration of cause, prior to repair activities.

6.6 SURFACE DEGRADATION FROM CONTAMINANTS

Verify correct version before use.

To prevent surface contaminants that can induce liquid and solid metal embrittlement, stress corrosion, hydrogen embrittlement, or reduce fracture toughness from coming in contact with the base material, the use of these substances on or with titanium is prohibited:

1. Mercury
2. Cadmium
3. Silver
4. Gold
5. Hydrochloric Acid
6. Chlorinated Cutting Oils and Solvents
7. Fluorinated Hydrocarbons
8. Methyl Alcohol
9. Methylene Chloride

7.0 PROCESS VERIFICATION

Process verification shall consist of the inspections described in sections 7.1 to 7.3. In addition, the manufacturer shall assure that fabrication activities are carried out in a manner that meets the requirements of this process specification and verify the following items at the appropriate time during fabrication activities.

- a) The welding operator is certified for the specific welding operation prior to welding.
- b) The fit-up is in accordance with the engineering drawing prior to welding for Class A and B Pressure Containing Components.
- c) A WPS exists prior to welding.
- d) Compliance with the WPS for essential variable ranges during welding.
- e) The PWHT is in accordance with the assigned WPS after welding.
- f) Weld one in-process control specimen at each of the following conditions:
 1. Prior to welding the first production joint during each shift.
 2. Upon changing from one certified machine setting to another.
 3. Upon discovery of unsatisfactory system performance.
 4. Specimens shall be visually inspected by an AWS Certified Welding Inspector (CWI).

7.1 CERTIFICATION AND QUALIFICATION OF INSPECTION PERSONNEL

7.1.1 Visual Inspection

Personnel performing visual inspections of Class A, B and C welds shall be an AWS CWI. The CWI certification must be current.

Verify correct version before use.

7.1.2 Nondestructive Inspection

Personnel performing acceptance inspections of flight hardware (Class I, II, IIIW and GSE – see Appendix C) shall be qualified and certified, at a minimum, to Level 2 in accordance with NAS 410. Personnel performing acceptance inspections requiring Special Non-Destructive Evaluation (NDE) shall also be qualified and certified for Special NDE in accordance with NASA-STD-5009.

Personnel performing acceptance inspections of non-flight hardware (Class III, STE/D, mockup, and facility hardware – see Appendix C) shall be qualified and certified in accordance with either NAS 410 or SNT-TC-1A. Personnel making accept/reject decisions shall, at a minimum, be certified to Level 2. Level 3 personnel making accept/reject decisions shall have successfully completed a hands-on practical examination equivalent to the examination required for Level 2. Level 1 personnel may perform acceptance inspections under the direct supervision of a Level 2 but shall not make accept/reject decisions.

Formal qualification and certification is not required for personnel performing engineering evaluation inspections.

Unless otherwise specified, all welds in a structure shall be subjected to the required inspections for the applicable weld class or classes. All unconsumed temporary or tack welds shall be placed where consumed by final weld and subjected to the level of inspection required by the highest weld class specified in the design documentation.

7.2 INSPECTION METHODS AND ACCEPTANCE CRITERIA

7.2.1 General

Inspections shall be performed in accordance with a written procedure by personnel certified in accordance with section 7.3.

7.2.2 Visual

Welds shall be visually inspected for conformance to the drawing requirements and acceptance shall be in accordance with the applicable Class A, B or C acceptance criteria in Appendix A or B.

7.2.3 Liquid Penetrant

- a) Non-Flight Hardware: Liquid penetrant inspections shall be performed per PRC- 6506. Unless otherwise specified, a fluorescent (Type I) Sensitivity Level 3 or 4 penetrant shall be used for Class A welds and Class B welds in pressurized components. Visible (Type II) penetrant may be used for Class B welds in non- pressurized and structural components. Acceptance shall be in accordance with the applicable Class A or B acceptance criteria in Appendix A or B.
- b) Flight Hardware: Liquid penetrant inspections shall be performed per
Verify correct version before use.

PRC-6506. Unless otherwise specified, a fluorescent (Type I) Sensitivity Level 3 or 4 penetrant shall be used. Acceptance shall be in accordance with the applicable Class A or B acceptance criteria in Appendix A or B.

7.2.4 Radiographic

- a) Non-Flight Hardware: Radiographic inspections shall be performed per PRC-6503. Acceptance shall be in accordance with the applicable Class A or B acceptance criteria in Appendix A or B. Gamma radiation sources shall not be used unless approved by the NASA/JSC M&P engineering organization. Approval of gamma radiation sources shall be based on demonstration of radiographic sensitivity equivalent to that obtainable with an X-ray source.
- b) Flight Hardware: Radiographic inspections shall be performed per PRC-6503. Acceptance shall be in accordance with the applicable Class A or B acceptance criteria in Appendix A or B.

7.2.5 Ultrasonic

- a) Non-Flight Hardware: Unless otherwise specified, ultrasonic inspections and acceptance shall be performed per PRC-6510, Class A.
- b) Flight Hardware: Ultrasonic inspections and acceptance shall be performed per PRC-6510, Class A.

7.3 REQUIRED INSPECTIONS

Unless otherwise specified, all welds in a structure shall be subjected to the required inspections for the applicable weld class or classes. Unconsumed temporary or tack welds shall be subjected to the level of inspection required by the highest weld class specified in the design documentation.

7.3.1 Class A

Class A welds require visual, surface and subsurface inspections. Surface inspections shall be accomplished using the liquid penetrant method. Subsurface inspections shall be accomplished using the radiographic method. In cases where the weld configuration renders adequate radiographic inspection impractical, an alternate inspection method shall be utilized as approved by the responsible M&P Engineering authority. When ultrasonic inspection is selected and approved as an alternate to radiographic inspection, the ultrasonic inspection shall be performed as specified in section 7.2.5. When liquid penetrant is the only available option for inspection and is selected and approved as an alternate to radiographic inspection, the liquid penetrant inspection shall be performed as specified in section 7.2.3. For multi-pass welds, inspections shall be performed on every pass.

7.3.2 Class B

Class B welds require visual and surface inspections. Surface inspections shall be accomplished using the liquid penetrant method.

Verify correct version before use.

7.3.3 Class C

Class C welds only require visual inspection.

8.0 PROCESS VERIFICATION

The WPS, PQR, and WPQ shall be prepared and retained as a permanent record and made available upon request to the responsible M&P organization for review. These procedures must contain, at a minimum, all of the essential welding variables (procedure qualification variables, etc.), an identification of the welding equipment, the pre-weld cleaning procedure (refer to Section 6.1.1) and include any pertinent tooling information. One copy of the WPS shall be maintained in the vicinity of the welding station and shall be readily accessible by the welders, inspectors, supervision, and engineering.

8.1 PROCEDURE QUALIFICATION VARIABLES

Applicable to all processes, the process variables considered “essential” and applicable to qualification of a welding processes/procedure shall be all those as required by AWS B2.1 and to include the following:

- a. A change from vertical downhill welding to vertical uphill or vice versa,
- b. A change from a stringer to a weave bead and vice versa,
- c. A change from multiple passes per side to a single pass per side, and vice versa,
- d. As deemed necessary by the responsible M&P organization, an increase or decrease in any one or more of the variables considered integral to the calculated heat input (i.e., current, voltage, and travel speed) beyond that which was qualified. Where necessary, the procedure shall include weld tests that define the tolerance ranges of specifically identified variables,
- e. For keyhole welding techniques, a change from keyhole to non-keyhole and vice versa.
- f. WPSs qualified outside of a weld chamber using trailing shields and gas purge assemblies may also be used for welding in a weld chamber, but not vice versa.
- g. Any deviations or waivers regarding the use of this process specification shall be requested in writing. This request shall be directed to the responsible M&P organization with the appropriate justification and rationale. A written response will be provided upon such a request.

8.2 WELDING PROCEDURE SPECIFICATION

A Welding Procedure Specification (WPS) is a qualified written working procedure that must be developed before beginning production for each unique weld type to be produced. Qualification support documentation in the form of a Procedure Qualification Record (PQR) shall be maintained on file to show proof of process/procedure capability using the WPS. The WPS shall be traceable by means of serialized nomenclature and shall show traceability to the applicable PQR(s). The WPS used for production welding shall meet the requirements of AWS B2.1 and shall be certified by the responsible M&P organization at the operating facility, prior

Verify correct version before use.

to use in production. If a qualified WPS does not exist prior to welding of production parts, one shall be qualified according to AWS B2.1 "Standard Test Weldments" at a minimum. "Prequalified" or "Standard Welding Procedure Specifications" shall not be permitted for production use on Class A or B welds made on flight hardware.

8.3 PROCEDURE QUALIFICATION RECORD

A Procedure Qualification Record (PQR) is documentation to support the welding procedure specification to show proof of process/procedure capability. A PQR shall be unique and traceable, by means of serialized nomenclature. The PQR shall be process specific and specific to a unique weld type. Data required in the PQR shall include detailed descriptions of the test coupon configurations and joint designs, all pertinent material specifications, all pertinent essential process variables used, all destructive and nondestructive test results from the qualification sample set, and all required certifications from the approving organization. The PQR shall be approved by the responsible M&P organization at the operating facility.

8.4 WELDER PERFORMANCE QUALIFICATION

A Welder Performance Qualification (WPQ) is documentation that shows that a welder has been tested in accordance with AWS B2.1 and shown competent to produce a sound weld for a specific welding process/base material/filler metal/position combination.

8.5 DEVIATIONS AND WAIVERS

Any deviations or waivers regarding the use of this process specification shall be requested in writing by the outside vendor. This request shall be directed to the responsible M&P organization with the appropriate justification and rationale. A written response will be provided upon such a request.

9.0 TRAINING AND CERTIFICATION OF PERSONNEL

9.1 TRAINING

Welder training (when necessary) should consist of practice using the facility welding equipment and a specific WPS to demonstrate proficiency, under the supervision of a qualified/certified welder. Specific development of an appropriate training program shall be the responsibility of the vendor.

9.2 WELDER QUALIFICATION

Welding shall be performed by a welder qualified and certified in accordance with AWS B2.1. Sufficiently detailed records shall be maintained to demonstrate continuity of performance qualification on a semi-annual (6 month) basis.

9.2.1 Additional Qualification Variables

When qualifying personnel for titanium welding, the welding setup shall be considered an essential variable. When qualifying personnel for titanium welding by the guided bend test method, titanium alloys not listed in AWS B2.1, Appendix C1 or C2, the plunger diameter (dimension "A" in Annex II of AWS B2.1) shall not

Verify correct version before use.

exceed 20T (10T radius). For the alloys listed in Appendix C, use the bend radiuses shown in the table.

10.0 **DEFINITIONS**

The following definitions (and associated acronyms) shall apply to this entire document:

1. **Ductility** – The ability of the material to be plastically deformed by elongation prior to fracture.
2. **Procedure Qualification Record (PQR)** – a detailed written record of the process that has been qualified. The record shall include all the applicable inspection and tests that were conducted and a record of the results of those tests. The PQR shall be signed (certified) by the responsible organization overseeing the welding operations.
3. **Repair** – an action taken to correct a production deficiency in the hardware that results in the hardware not meeting the original design but is fully functional and serviceable as intended by the design.
4. **Rework** – an action taken to correct a production deficiency in the hardware that results in the hardware meeting the original design and is fully functional and serviceable as intended by the design.
5. **Toughness** – A property of a material capable of absorbing energy by plastic deformation. Low energy absorption is considered brittle and high energy absorption is considered ductile.
6. **Welding Procedure Specification (WPS)** – a detailed written procedure that is used by a welder to ensure that the execution of the qualified process is carried out as intended.

Verify correct version before use.

Appendix A

WELD ACCEPTANCE CRITERIA

A1.0 GENERAL

If any of the acceptance criteria given below conflict with the engineering drawing requirements, then the stricter criteria shall apply. The symbol 'T' shall equal the nominal base metal thickness of the thinnest component in the welded connection. The weld length shall be the distance from end to end of the weld deposit or to a sharp change in weld direction where the angle of change in any direction is greater than 30° with a radius of less than 1/2". Unless otherwise stated, the criteria in this Appendix shall apply to all weld classes. Alternate and/or additional acceptance criteria, when applicable, shall be specified in the design documentation.

Brushing of titanium welds is not allowed prior to visual and surface inspection.

Table A1.0. Acceptance Criteria

ITEM	DISCONTINUITY TYPE	Class A	Class B	Class C
1.0	CRACKS IN THE WELD OR BASE METAL	None allowed	None allowed	None allowed
2.0	OVERLAP (COLDLAP)	None allowed	None allowed	None allowed
3.0	INCOMPLETE FUSION	None allowed	None allowed	None allowed
4.0	INCOMPLETE PENETRATION⁽¹⁾	None allowed	None allowed	None allowed
5.0	POROSITY – SURFACE⁽²⁾			
5.1	Maximum Individual Size ^(3 & 4)	0.25T or 0.030" whichever is less	0.33T or 0.060" whichever is less	0.50T or 0.090" whichever is less
5.2	Minimum Spacing	8x the size of the larger adjacent pore	4x the size of the larger adjacent pore	2x the size of the larger adjacent pore
5.3	Maximum Accumulated Length in any 3" of Weld ⁽⁵⁾	1T or 0.12" whichever is less	1.33T or 0.24" whichever is less	2T or 0.36" whichever is less
6.0	POROSITY – SUBSURFACE⁽²⁾			
6.1	Maximum Individual Size ^(3 & 4)	0.33T or 0.060" whichever is less	0.50T or 0.090" whichever is less	Not Applicable
6.2	Minimum Spacing	4x the size of the larger adjacent pore	2x the size of the larger adjacent pore	Not Applicable
6.3	Maximum Accumulated Length in any 3" of Weld ⁽⁵⁾	1.33T or 0.24" whichever is less	2T or 0.36" whichever is less	Not Applicable
7.0	INCLUSIONS⁽²⁾			
7.1	Maximum Individual Size ^(3 & 4)	0.33T or 0.060" whichever is less	0.50T or 0.090" whichever is less	Not Applicable
7.2	Minimum Spacing	4x the size of the larger adjacent inclusion	2x the size of the larger adjacent inclusion	Not Applicable
7.3	Maximum Accumulated Length in any 3" of Weld ⁽⁵⁾	1.33T or 0.24" whichever is less	2T or 0.36" whichever is less	Not Applicable
8.0	UNDERCUT			
8.1	Full Length of Weld, Maximum Depth	0.002"	0.015T or 0.002", whichever is greater	0.025T or 0.002", whichever is greater

Verify correct version before use.

ITEM	DISCONTINUITY TYPE	Class A	Class B	Class C
8.2	Maximum Individual Defect	0.07T or 0.03", whichever is less	0.10T or 0.05", whichever is less	0.20T or 0.07", whichever is less
8.3	Maximum Accumulated Length in any 3" of Weld ⁽⁵⁾	0.20"	0.60"	1.00"
9.0	FACE OR ROOT UNDERFILL – GROOVE WELDS			
9.1	Full Length of Weld, Maximum Depth	0.005"	0.015T or 0.005", whichever is greater	0.025T or 0.005", whichever is greater
9.2	Maximum Individual Defect	0.07T or 0.03", whichever is less	0.07T or 0.03", whichever is less	0.07T or 0.03", whichever is less
9.3	Maximum Accumulated Length in any 3" of Weld ⁽⁵⁾	0.20"	0.60"	1.00"
10.0	CRATERS			
10.1	Maximum Depth	0.20T or 0.03", whichever is less	0.20T or 0.05", whichever is less	0.20T or 0.05", whichever is less
10.2	Maximum Length	1T	1T	2T
11.0	ARC STRIKES AND GOUGE MARKS	Unacceptable	Unacceptable	Unacceptable
12.0	WELD REINFORCEMENT - MANUAL WELDS			
12.1	Material < 0.125"	1T maximum	No stated requirement	No stated requirement
12.2	Material 0.125" to 0.510"	1T or 0.100" maximum, whichever is greater	No stated requirement	No stated requirement
12.3	Material > 0.510"	0.170" maximum	No stated requirement	No stated requirement
13.0	PEAKING	3 degrees max	5 degrees max	No stated requirement
14.0	MISMATCH BETWEEN MEMBERS AFTER WELDING	T/10 or 1/8", whichever is less	T/5 or 3/16", whichever is less	No stated requirement
15.0	FILLET WELDS			
15.1	Weld Profiles	See Fig. A2.0	See Fig. A2.0	See Fig. A2.0
15.2	Weld Size (Size Stated on Drawing)	As shown by welding symbol	As shown by welding symbol	As shown by welding symbol
15.3	Minimum Weld Size (Size Not Stated on Drawing) – Single Side Fillet	1.5T	1.5T	1.5T
15.4	Minimum Weld Size (Size Not Stated on Drawing) – Double Side Fillet	1.0T	1.0T	1.0T
15.5	Maximum Weld Size – Size Stated on Drawing			
15.6	Material ≤ 0.090"	2.0x	2.0x	2.0x
15.7	Material 0.091" – 0.156"	1.5x	1.5x	1.5x
15.8	Material 0.157" – 0.750"	1.25x	1.25x	1.25x
15.9	Material ≥ 0.751"	1.1x	1.1x	1.1x
16.0	DISCOLORATION⁽⁶⁾⁽⁷⁾			
16.1	Bright Silver	Acceptable	Acceptable	Acceptable
16.2	Silver	Acceptable	Acceptable	Acceptable
16.3	Light Straw	Acceptable	Acceptable	Acceptable
16.4	Dark Straw	Reject	Acceptable	Acceptable
16.5	Bronze	Reject	Reject	Reject
16.6	Brown	Reject	Reject	Reject
16.7	Violet	Reject	Reject	Reject
16.8	Green	Reject	Reject	Reject
16.9	Any Shade of Blue	Reject	Reject	Reject

Verify correct version before use.

ITEM	DISCONTINUITY TYPE	Class A	Class B	Class C
16.10	Gray	Reject	Reject	Reject
16.11	White	Reject	Reject	Reject
17.0	LOOSE OXIDATION AND SCALE	Reject	Reject	Reject

- (1) Applicable to groove welds only.
- (2) For all discontinuities approaching a free edge (See Figure A1.0), the closest edge of the discontinuity shall have clearance from the free edge $\geq 3X$ the largest of its dimensions or $\geq 2X$ the nominal weld throat, whichever is greater.
- (3) Adjacent rounded discontinuities separated by $\leq 1X$ the length of the longer discontinuity shall be considered a single discontinuity.
- (4) Adjacent elongated discontinuities separated by $\leq 3X$ the diameter of the larger discontinuity, shall be considered a single discontinuity.
- (5) For weld lengths less than 3", the total sum of indications shall be an equivalent proportion of the weld length.
- (6) Refer to AWS G2.4, Figure 7, for weld color examples.
- (7) Welds that have been brushed before inspection can be rejected regardless of color before brushing.

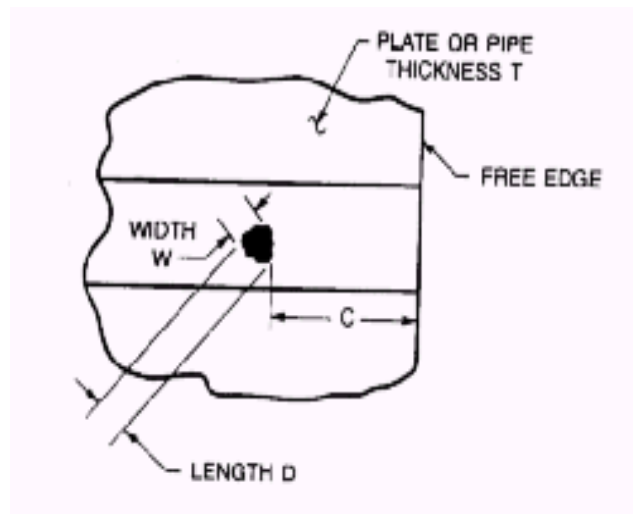

C = Clearance spacing between closest edge of discontinuity and free edge

FIGURE A1.0 – DISCONTINUITY APPROACHING A FREE EDGE

Verify correct version before use.

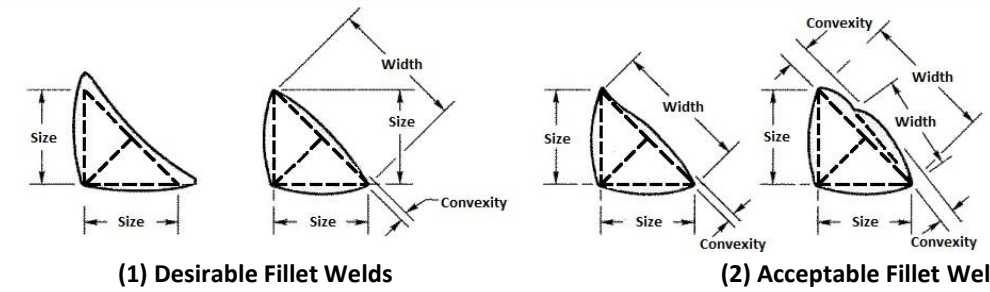

Note: Convexity of a weld or individual surface bead with dimension Width shall not exceed the value of the following table.

Width of Weld Face or Individual Surface Bead	Maximum
Convexity Allowed Width $\leq 5/16''$	$1/16''$
Width $> 5/16''$ to Width $< 1.00''$	$1/8''$
Width $\geq 1.00''$	$3/16''$

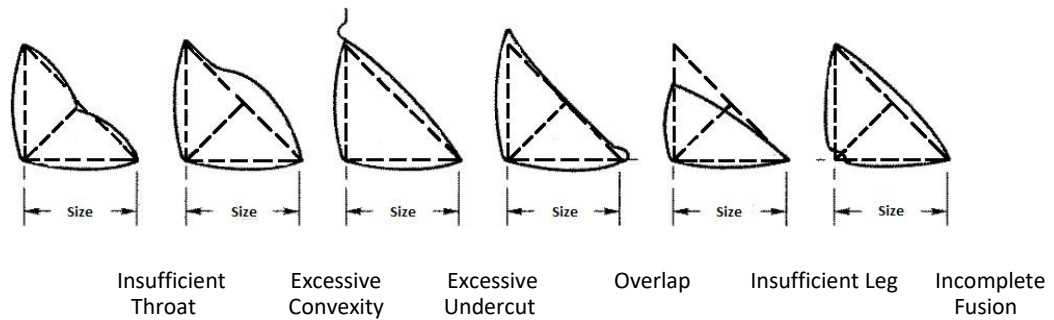

(3) Unacceptable Fillet Weld Profiles

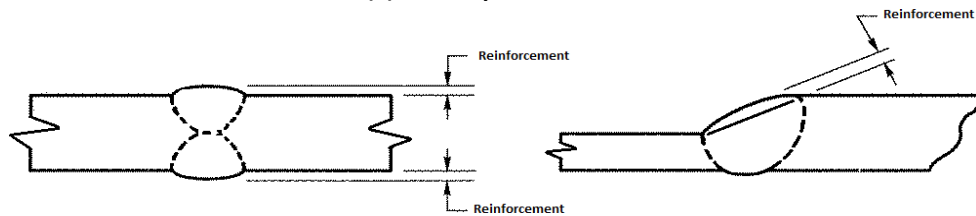

(4) Acceptable Groove Weld Profiles in Butt Welds

Note: Reinforcement shall not exceed $1/8''$.

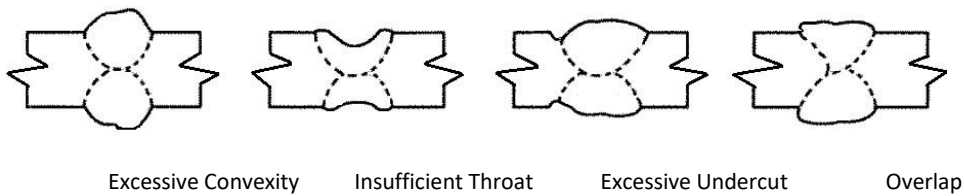

(5) Unacceptable Groove Weld Profiles in Butt Joints

Figure A2.0 – ACCEPTABLE AND UNACCEPTABLE WELD PROFILES

Verify correct version before use.

Appendix B

Hardware Classification

Hardware Classification	
Class I	Flight hardware - refers to any hardware acceptable for space flight use
Class II	Ground tests or training in a hazardous environment
Class IIIW	Hardware used in water immersion training
GSE	Ground Support Equipment
Class III	“Non-Flight hardware” refers to any hardware acceptable for use in non- hazardous training or displays
STE/D	Special Test Equipment/Devices used in facilities (buildings and related accessories), mockup mission equipment and engineering prototype and development hardware.
1E	Any combination of hardware and software that is developed and operated to answer a scientific or engineering question that cannot be addressed in a terrestrial environment. Operating this hardware does not provide mission critical functions, and hazards are eliminated or controlled such that the safety of the crew, the space vehicle, or launch vehicle are not compromised.

Verify correct version before use.

Verify correct version before use.

Appendix C

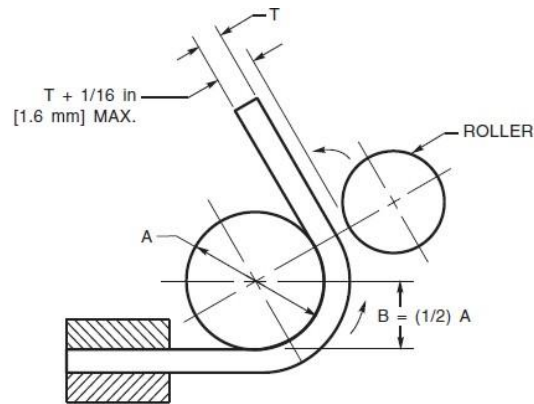

Material M Number (Grade)	Mandrel Diameter A	Bend Radius B
51 (Grade 1)	8 × test coupon thickness	4 × test coupon thickness
51 (Grade 2)	8 × test coupon thickness	4 × test coupon thickness
52 (Grade 3)	10 × test coupon thickness	5 × test coupon thickness
53 (Grade 9)	16 × test coupon thickness	8 × test coupon thickness
53 (Grade 5)	16 × test coupon thickness	8 × test coupon thickness
54 (Grade 23)	16 × test coupon thickness	8 × test coupon thickness
(Grade 38)	18 × test coupon thickness	9 × test coupon thickness

Notes:

1. Dimensions not shown are the option of the designer. The essential consideration is to have adequate rigidity so that the fixture parts will not spring.
2. The specimen shall be firmly clamped on one end so that there is no sliding of the specimen during the bending operation.
3. Test specimens shall be removed from the fixture when the outer roll has moved 120° from the starting point and the center of the weld is contained within an area that has been subjected to the maximum possible strain, typically between 60° and 90° from the start.
4. The test fixture mandrel shall be at least 0.25 in [6 mm] wider than the specimen being tested.

Figure 3.16—Wraparound Guided Bend Jig (see 3.11.2.1)

Grade 1 = CP Ti (min. 20 ksi YS)

Grade 2 = CP Ti (min. 40 ksi YS)

Grade 3 = CP Ti (min. 55 ksi YS)

*Grade 4 = CP Ti (min. 70 ksi YS)

Grade 5 = 6Al-4V Ti

Grade 9 = 3Al-2.5V Ti

Grade 23 = 6Al-4V ELI Ti

Grade 38 = 4Al-2.5V-1.5Fe Ti

*Use Mandrel Diameter A and Bend Radius B given for Grade 3.

Verify correct version before use.