

U.S. Naval Academy Small Satellite Program's Story: Lessons Learned and Un/common Practices

14 NOV 2019

Jin S. Kang and Robert Bruninga



Naval Academy Small Satellite Program (NASSP)



The foundation of our space systems curriculum for the Astro Track students

- Provides midshipmen full-range of hands-on space system development experiences
 - Satellite design
 - Bus and payload development, integration, and testing
 - Mission operation
- Guides students through regulatory and validation procedures
- Educates future naval officers
- Research for future space technologies



Missions:

- Sapphire
- BRICSat
- PCSat
- QIKCOM-1 (hosted)
- PCSat-2 (ISS)
- QIKCOM-2 (hosted)
- ANDE
- BRICSat-2
- MidSTAR
- PSAT-2
- RAFT/MARScom
- RSat
- PSAT
- DRAGONsat
- USS Langley



Shaker



Thermal and Thermal Vacuum Chambers



Solar Simulator

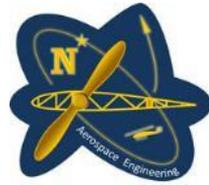

PCSAT (2001)

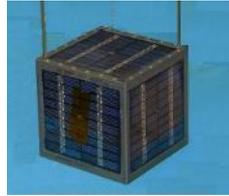

RAFT(2006)



ARISS on ISS

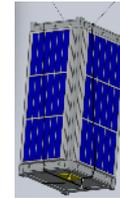

PSAT(2015)

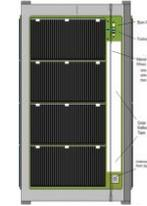

PSAT-2(2017)



PCSAT2(2006)



ANDE(2006)

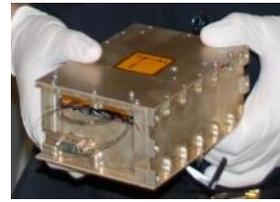

QIKCOM-1 on ISS



QIKCOM-2 (Aug 2016)

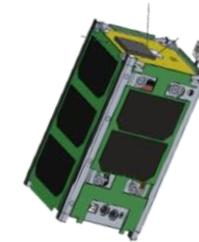

- Education and training, not product
- Did we deliver and launch? → success

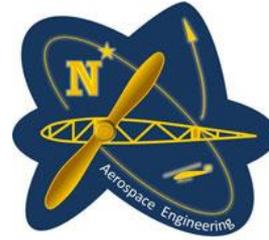

Past Projects



USNA-1: PCSat

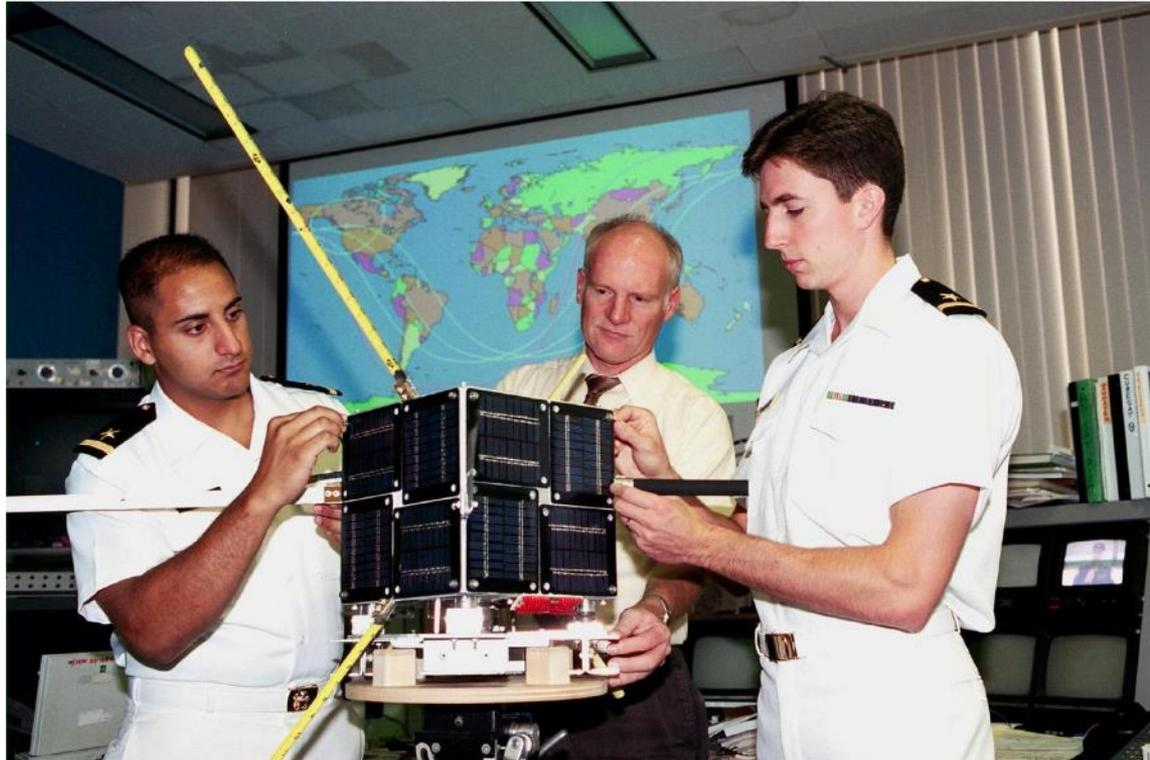
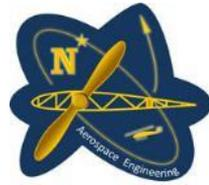

PCSat, active

- First USNA space launch
- Two-way hand-held APRS communications
- Oldest surviving student-built satellite in space
- Launched in Sept. 2001



USNA-8: DragonSat-1

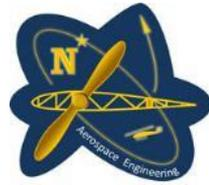

DRAGONSat-1

- First USNA CubeSat
- 1U satellite with a 1.5 m long gravity gradient boom
 - 60 g tip mass for passive stabilization
- Launched on NASA ELaNa IV mission in Nov. 2013

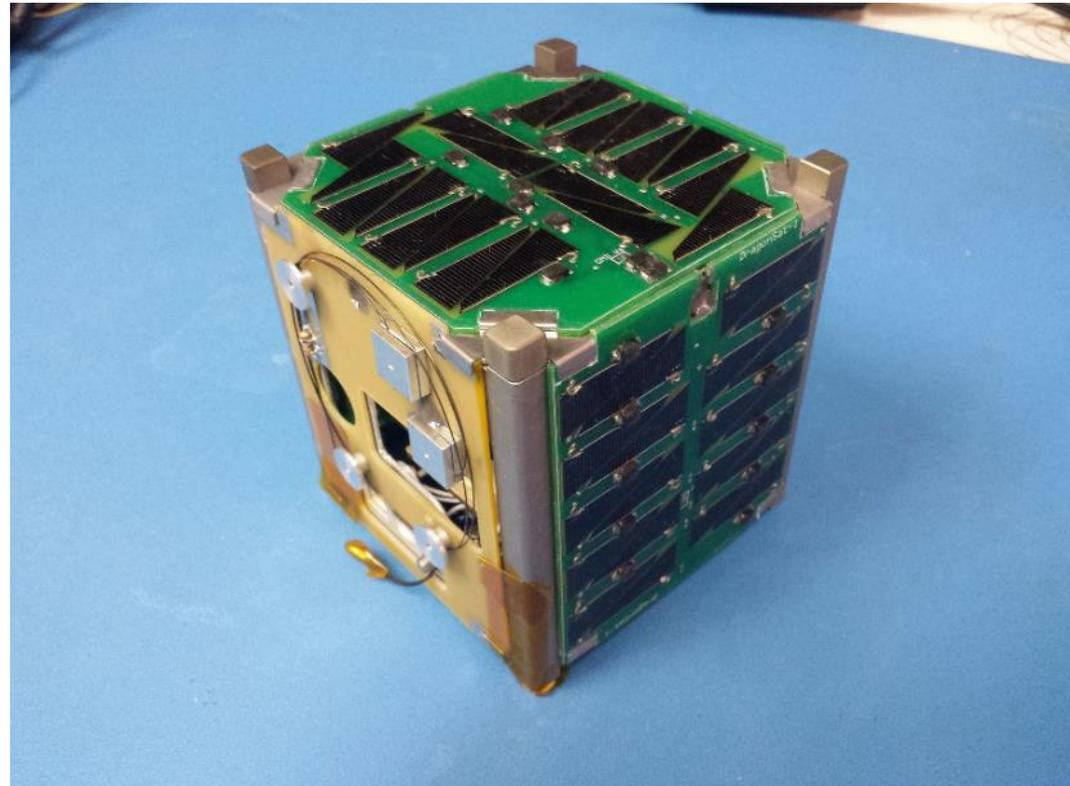



USNA-7: PSAT-1

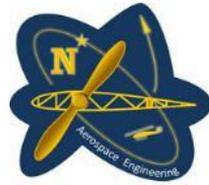

PSAT-1, active

- 1.5U CubeSat supporting follow-on mission of PCSat
- Supports Amateur Radio PSK31 multi-user text messaging
- Launched on ULTRA mission in May 2015

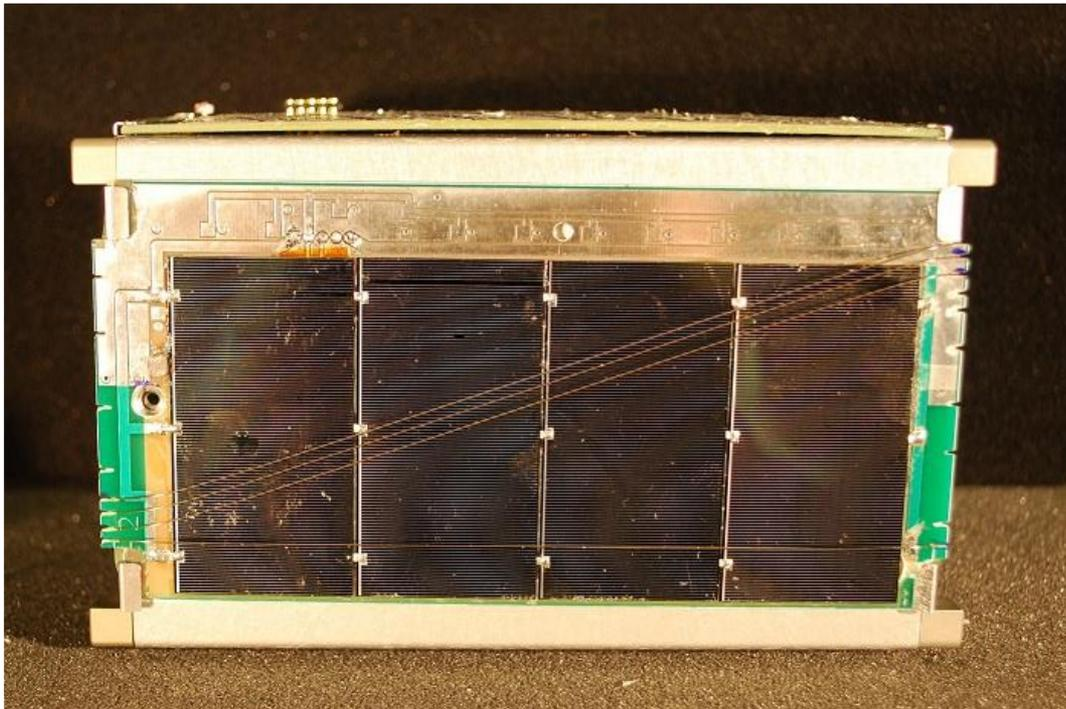



USNA-10: USS Langley

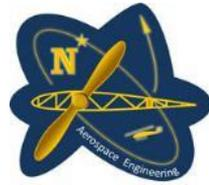

USS Langley

- 3U Colony-1 CubeSat
- Linux-based file server operating on S-band
 - Demonstrate on-orbit internet server capability
- Launched on ULTRA mission in May 2015

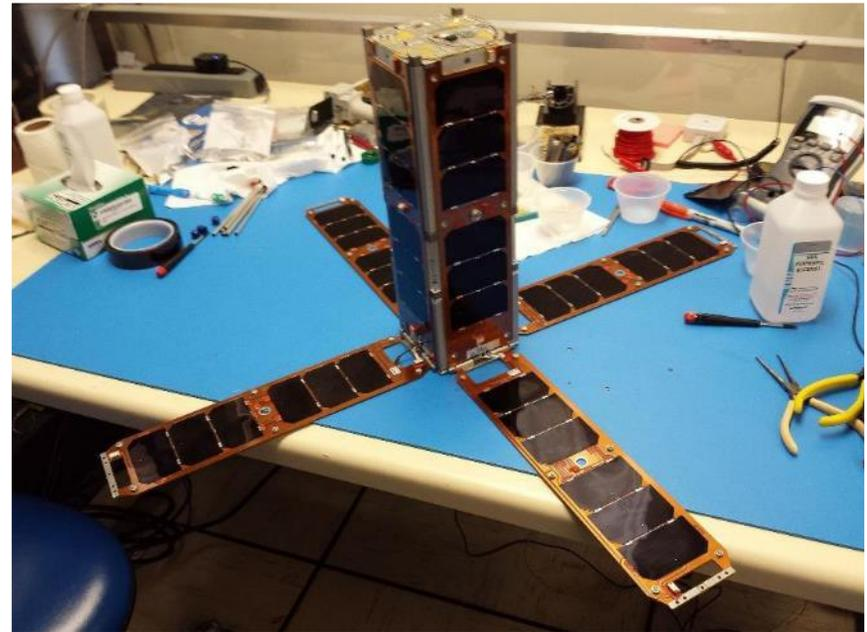



USNA-11: BRICSat-1

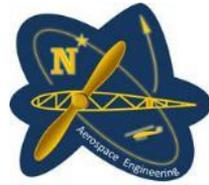

BRICSat-1

- 1.5U CubeSat testing attitude control
 - Four micro-cathode electrical thrusters from George Washington University
- Supports Amateur Radio PSK31 multi-user text messaging
- Launched on ULTRA mission in May 2015



USNA-19: RSat

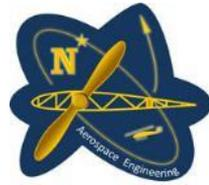

RSAT

- 3U CubeSat for robotic investigations and manipulation in space
 - 3D-printed robotic arms with seven degrees of freedom include cameras on each end
- Launched on NASA ELaNa XIX mission in Dec. 2018

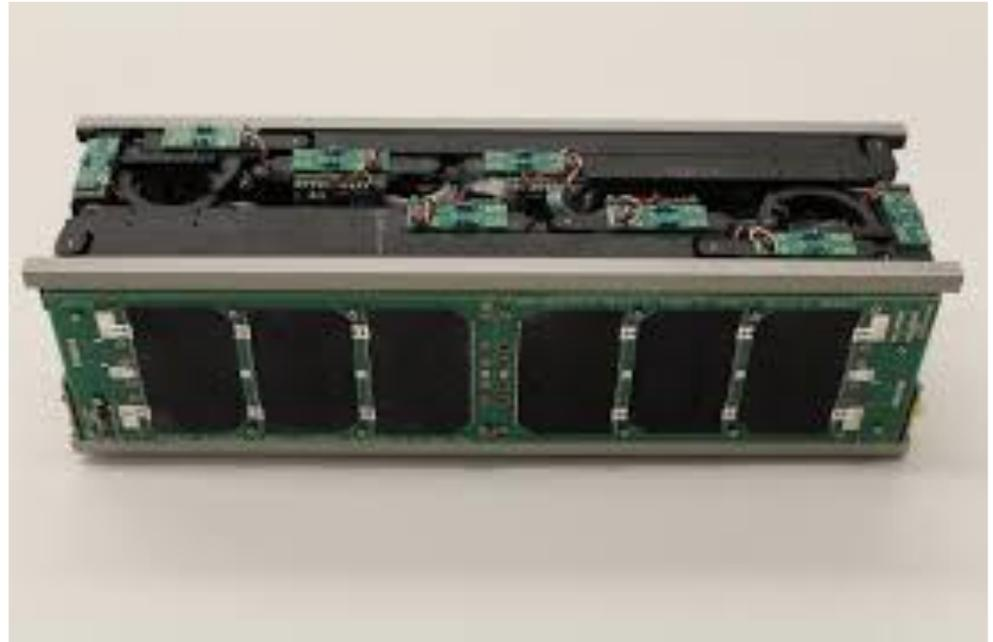

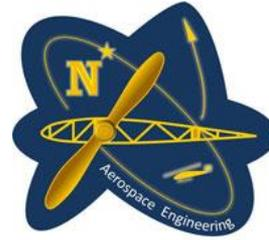

Recent Projects



USNA-14: BRICSat-2

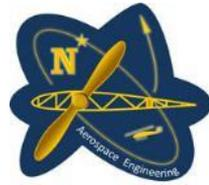

BRICSAT-2, active

- 1.5U CubeSat continuing to test attitude control
- Micro-cathode electrical thrusters from George Washington University
- Supported AX.25 Packet Radio Digipeater



USNA-15: PSAT2

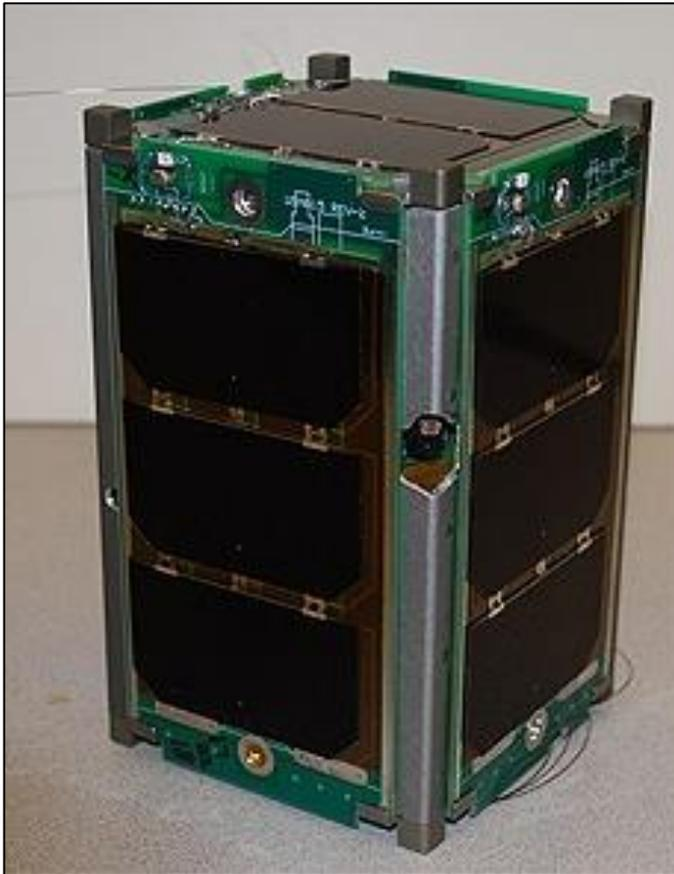
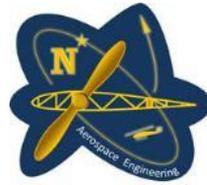

PSAT2, active

- Follow on to PSAT-1
- Integrated APRS command and control and transponder on a single circuit
- Includes the PSK-31 HF/UHF xponder
- Touchtone Texting
- Texting-to-voice synth
- SSTV camera



USNA-16: PSAT3

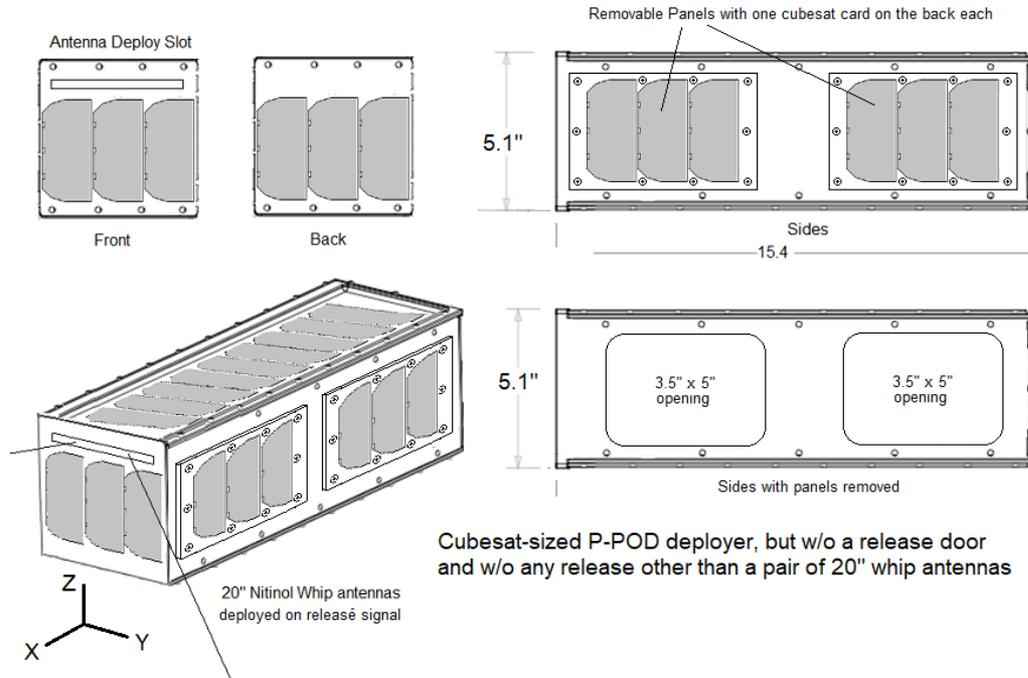
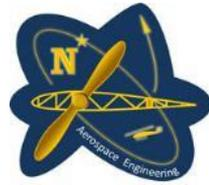

Included in PSAT3:

- Amateur radio transponder
 - SATT4 comms board
- Touchtone-Texting
- Text-to-voice synthesizer
- Nitinol whip antenna
- Burn-release mechanism
- Brno University SSTV camera



USNA-17: NSTAR

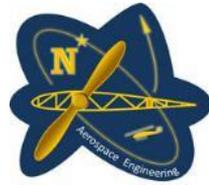

NSTAR

- 3U Robotic testing platform
- Internal ISS experiment
- Demonstrate on orbit robotic assembly of spacecraft and satellites

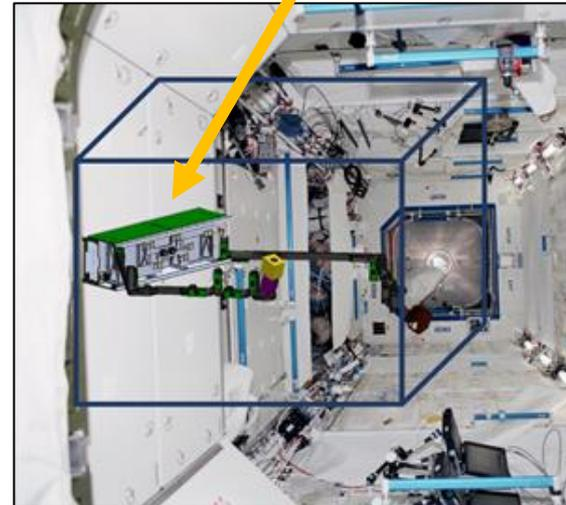
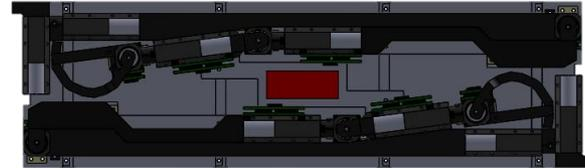

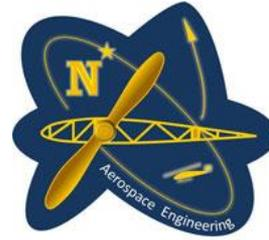

Lessons Learned: Education and Training



Some Unique Aspects of NASSP

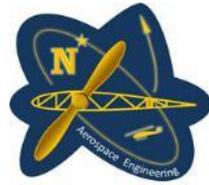

- All undergraduate students
 - Great for students – they get to manage full project and equipment
 - Not so great for long duration project – continuity of project lies ONLY with professors
- Requires much shorter development cycle





CDIO Model



- Conceiving – Designing – Implementing – Operating (CDIO) is great
 - CDIO is an innovative educational framework for producing the next generation engineers
 - Fits very well with NASSP's Vision
 - Great model for Capstone Design curriculum
- But added challenges for CubeSat community due to difficulties associated with:
 - Finding and coordinating for launch
 - Launch slips
 - Licensing timeline
 - Other regulatory restrictions



NASSP's O-CDI model



Start here!



USNA Satellite Dish



USNA Ground Station

Concept

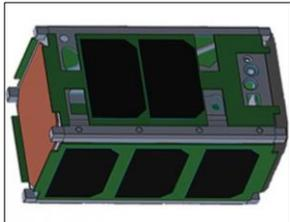

PSAT-2 Concept

Operation

Research and Design

- Provides midshipmen full-range of hands-on space system development experiences
 - Satellite design
 - Bus and payload development, integration, and testing
 - Mission Operation
- Guides students through regulatory and validation procedures
- Educates future naval officers
- Research for future space technologies



RSAT Solar Panel Construction



Thermal and Thermal Vacuum Chambers

Test

Fabrication



BRICSAT-1 Construction



Solar Simulator



Shaker



My Take on Current Landscape

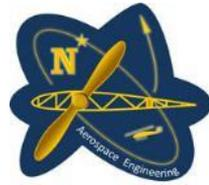

- CubeSat-class satellites missions becoming more and more important
 - From school projects to key mission enablers for government
 - Simple experiments to key capability augmentation tool

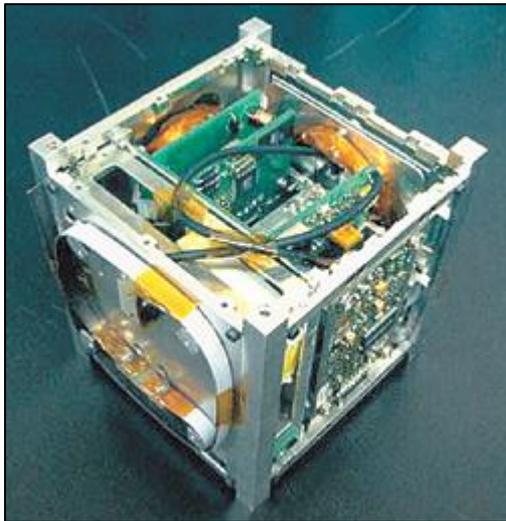

HAUSAT-1

[news.donga.com]

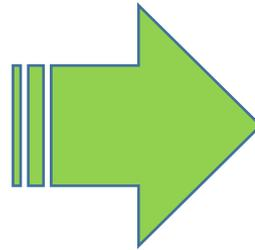

MARCO

[<https://solarsystem.nasa.gov/resources/2281/marco-cubesat-test/>]



Industry Engaged and Moving Fast

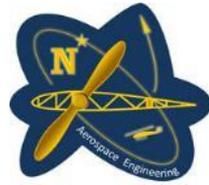

- Many small satellite or CubeSat specific companies providing high-tech solutions



SmallSat Conference

[\[https://alen.space/smallsat-2018-utah/\]](https://alen.space/smallsat-2018-utah/)

- Dedicated launch vehicles are now available



Electron Launch Vehicle

[\[nasaspaceflight.com\]](https://www.nasaspaceflight.com/)



All Well and Good... But Poses Challenges

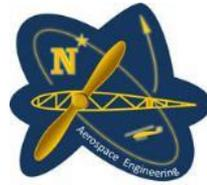

- Vendor specifications change too often
- Price and capability continue to increase, beyond what is needed at student-project level
- More attention from the government, resulting in an increase in regulatory requirements
- Makes it hard to fit student schedule and curriculum
 - Need a “standard bus” that can shorten the development cycle
 - (Almost) impossible to nail down a standard bus due to frequent changes

NASSP Solution: two flavors of student satellite projects



Dual-track CubeSat Projects

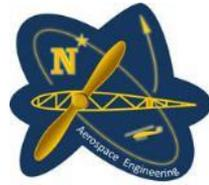

Multi-year, higher capability CubeSat project

- Consists of COTS components
- Often mission oriented
- Higher capability using higher performance parts
- Multi-disciplinary
- Students of all class years

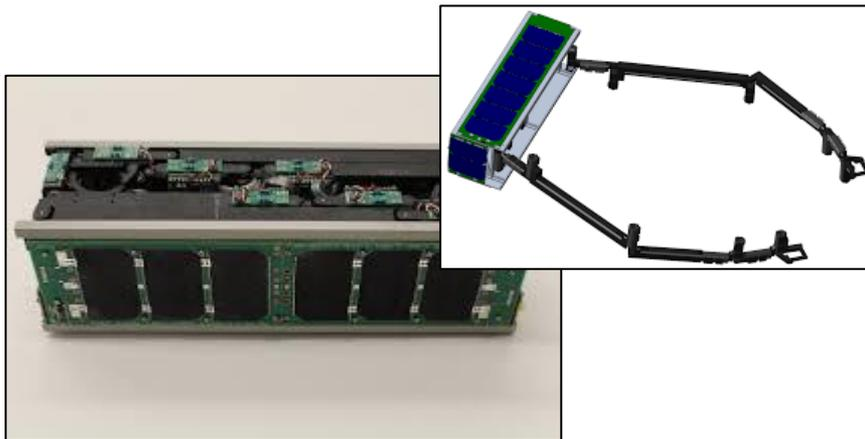

CubeSat projects leveraging in-house standard bus

- Electronics developed and built in-house by NASSP Senior Engineer, Bob Bruninga
- Put together by student teams in 2 months
- Education/training/tech-demo oriented missions
- Lower-performance
- **Independent of vendor changes**

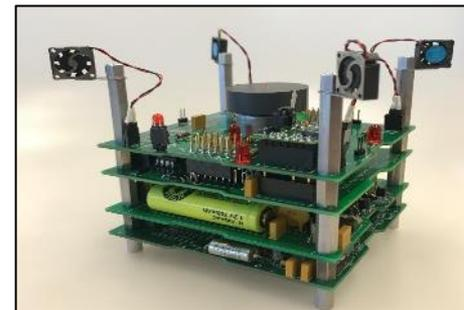



PSAT Standard Bus

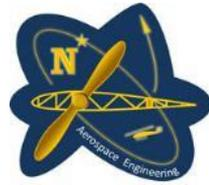

- Based on PSAT-1, 2 currently on orbit
- Enables development cycle to be reduced to one year
 - Perfect fit for year-long Capstone Design curriculum for seniors
 - Students can concentrate on payload and mission development
 - Provides hands-on education of building satellites

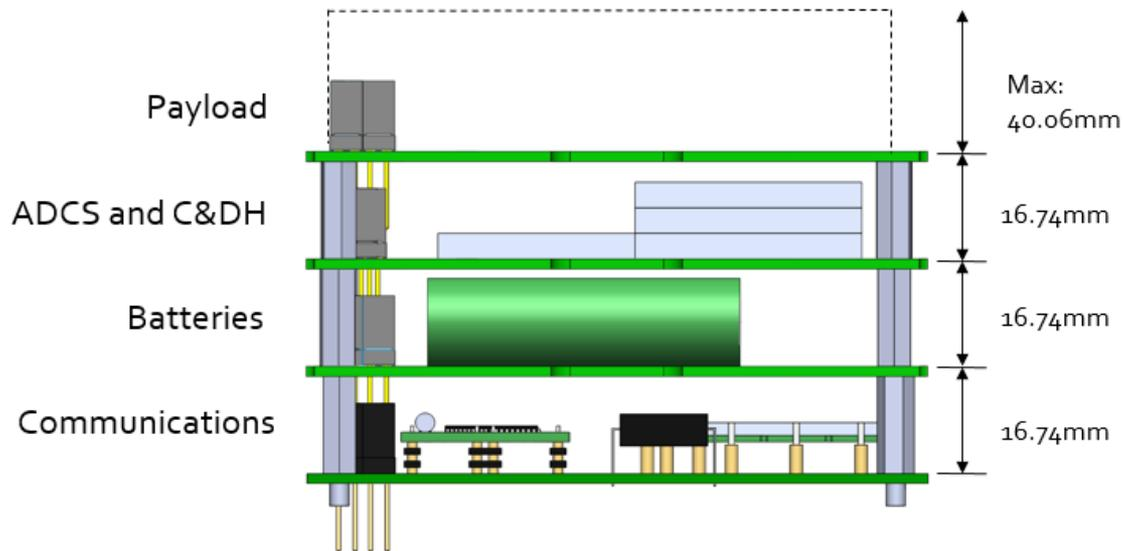



Current Capstone Design Model

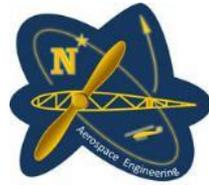

- Applying the Conceive Design Implement Operate (CDIO) initiative, students will develop multiple satellites every year as a part of the project curriculum
 - Approximately 4 teams each year
 - Completely student-built using in-house manuals
 - Exceptional components will be assembled into flight satellites
 - One or two complete satellites every year
 - Stored on the shelf and flown on available launch opportunities
 - Other components will be assembled into LabSats to be used as an in-class education tool

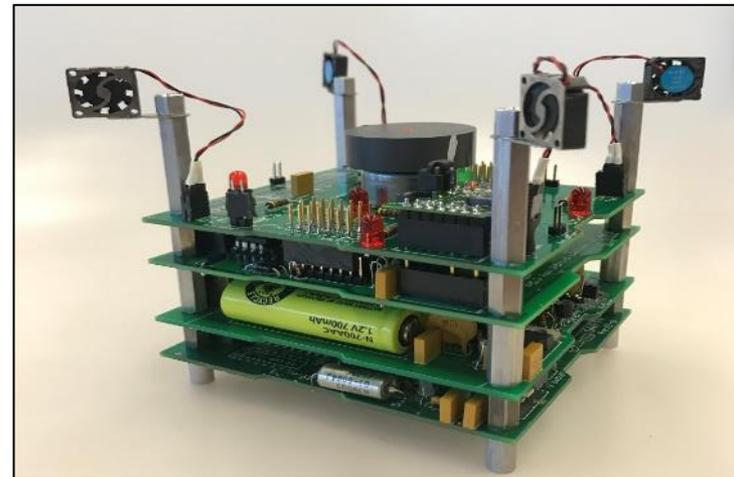
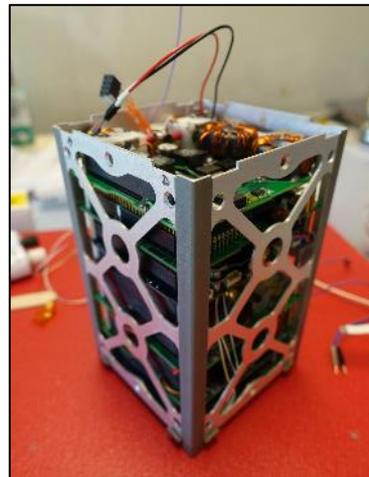



PSAT Specs and Subsystems

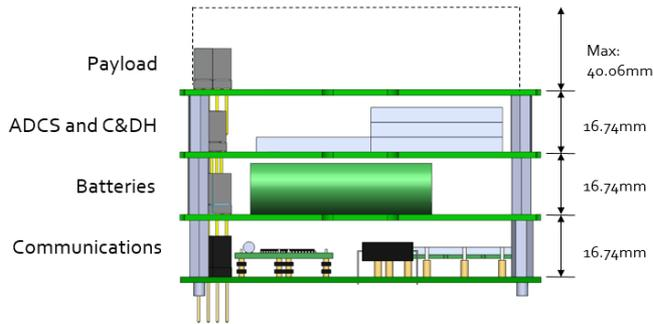
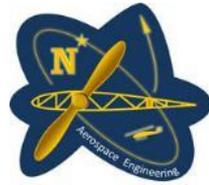

Satellite Specifications	
Mass	Max: 1500 g
Size	1U
Power Generation	2.85 W in sunlight
ADCS	Magnetorquers
Communications VHF (data)	145.825 MHz (uplink and downlink)

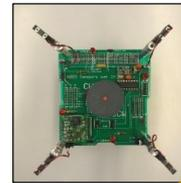

Payload



ADCS and C&DH

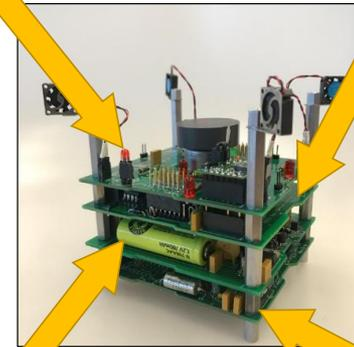

Batteries



Communications



Concentrating on Payload Development

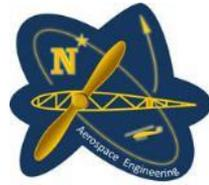

Payload Development

- Each student team will develop their own payload
 - Partnerships with other organizations
- Payload requirements:
 - Volume: 247.1 cm^3
 - Max height: 4.0 cm
 - Max width: 8.0 cm
 - Max depth: 7.7 cm
 - Power: 1.92 @
 - Daylight at 3.3 V
 - Mass: 566 g

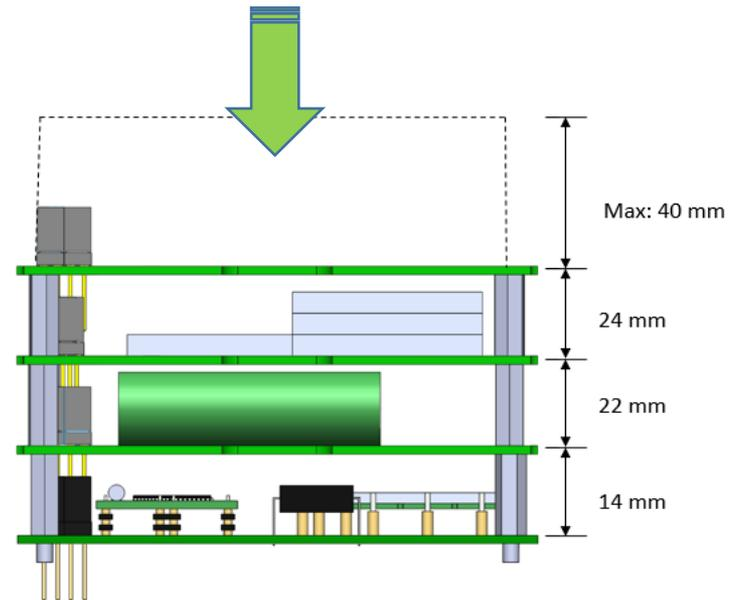
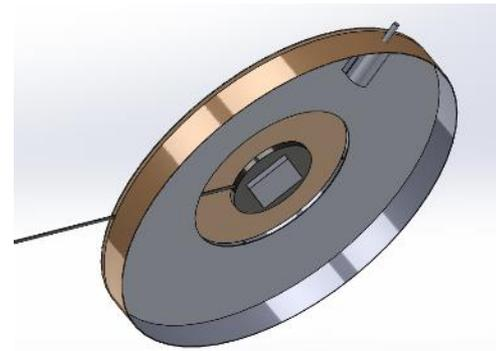

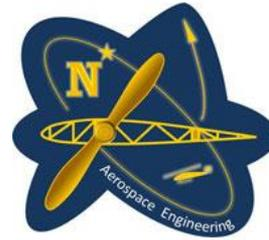

Amateur Radio is an Important Part of Education and Training



Amateur Radio is Great

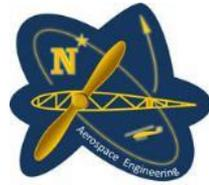

**145.825 MHz - A satellite relay channel for
Amateur Satellite User data anywhere on earth.**

Engineering Educational Objective:

One or two semester student engineering projects



Individual engineering responsibility

Low cost

Driven to completion

Where Failure (learning) is an option



Quicker Student involvement using a Ground Terminal Operational Missions

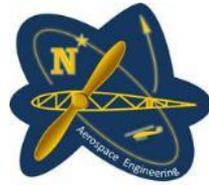

Ground Terminal Applications Focus (force tracking and text-messaging)

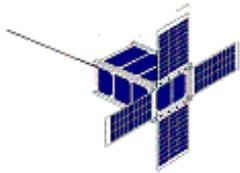

**Supports Student Experimenters
School missions/movements
Theater area communications
and Emergency Response Comms**

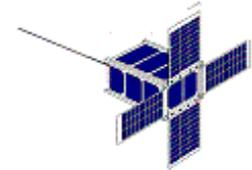

13th Co Army/Navy Football Run
Comms by USNA Radio Club
W3ADO



30 Nov 2001

de WB4APR

**Education
Force
Multiplier!**



The Yard Patrol Craft



APRS Satellite Network Users

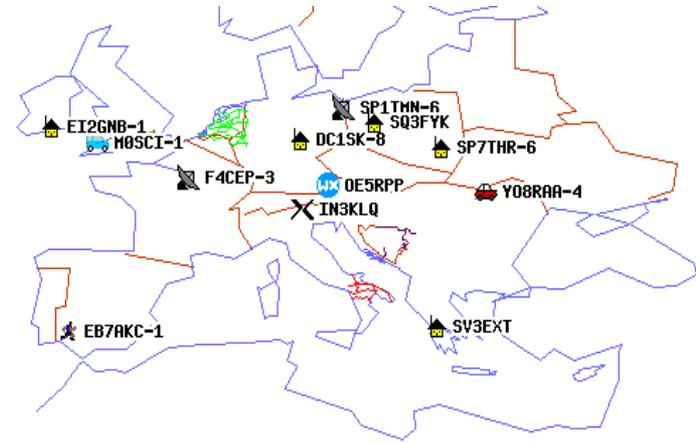
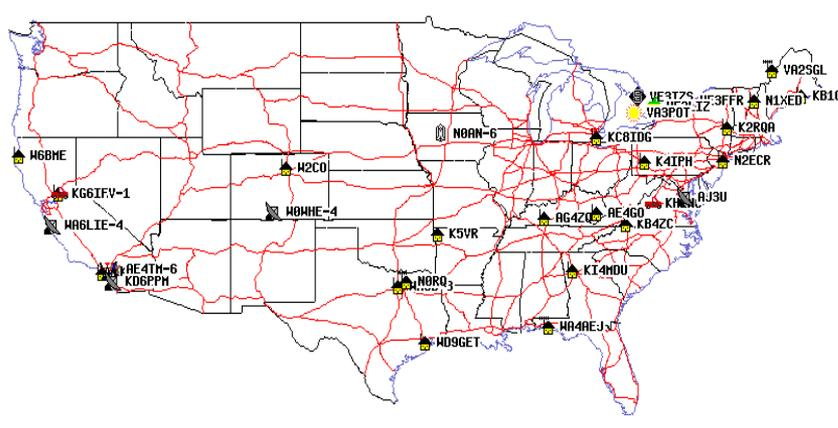
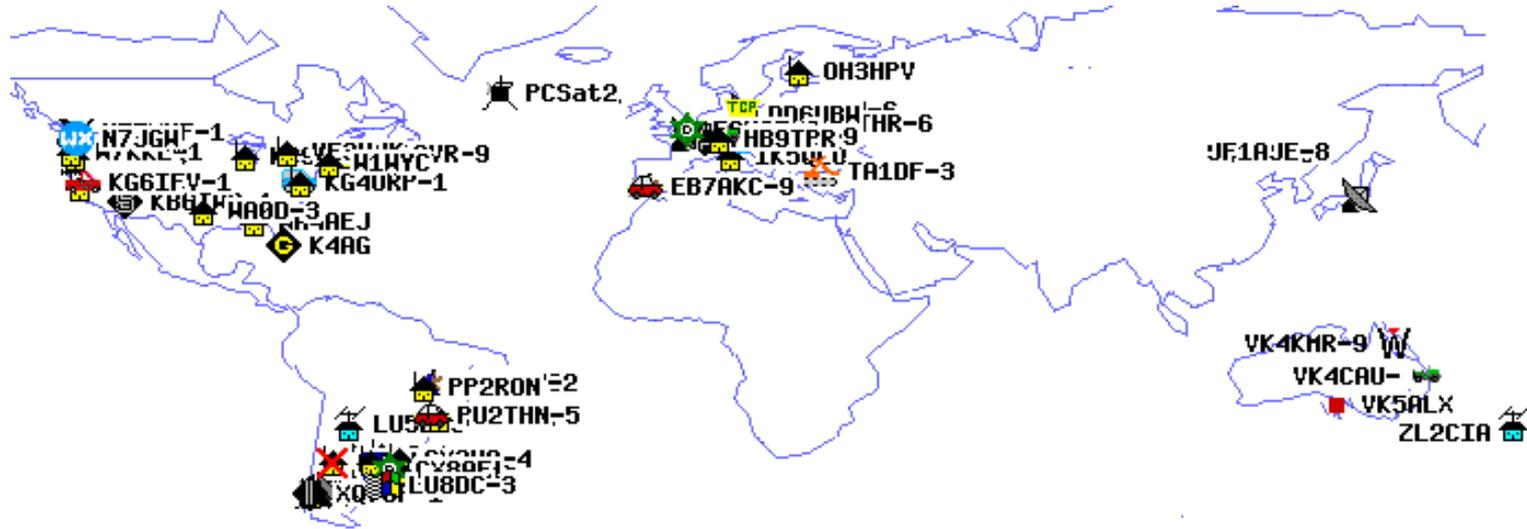
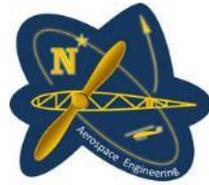



All Volunteer World-wide Coverage

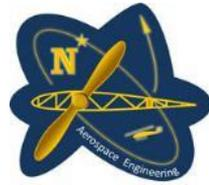

- PSAT-1 launched in May 2018
- Data from the first 18 months of operation (still going strong):

Telemetry Packets Collected

- 335 users captured data packets and logged them online
- 57,972 unique telemetry packets were collected

Digipeat Service Users

- 550 users from 44 different countries
- More than 22,121 user messages

COUNTRY	NUMBER OF USERS
USA	227
UNITED KINGDOM	36
GERMANY	30
ITALY	24
SPAIN	23
CANADA	19
ARGENTINA	18
ROMANIA	15
NETHERLANDS	14
AUSTRALIA	11
AUSTRIA	10
INDONESIA	10
POLAND	10
FRANCE	9
JAPAN	9
BELGIUM	8
RUSSIA	8
GREECE	6
TRINIDAD & TOBAGO	6
CROATIA	5
MEXICO	5
PORTUGAL	5
SWEDEN	5
BRAZIL	4
SWITZERLAND	4
IRELAND	3
NEW ZEALAND	3
THAILAND	3
CHILE	2
NORWAY	2
SERBIA	2
TURKEY	2
CHINA	1
CUBA	1
CZECH REPUBLIC	1
DENMARK	1
ERITREA	1
FINLAND	1
HUNGARY	1
INDIA	1
ISRAEL	1
MALAYSIA	1
MOLDOVA	1
UKRAINE	1



Like Having Multiple Ground Stations



- Very little telemetry data gaps
- You can almost fly these satellites without a dedicated command and control ground station
 - Would require asking the community to send up your command, etc.

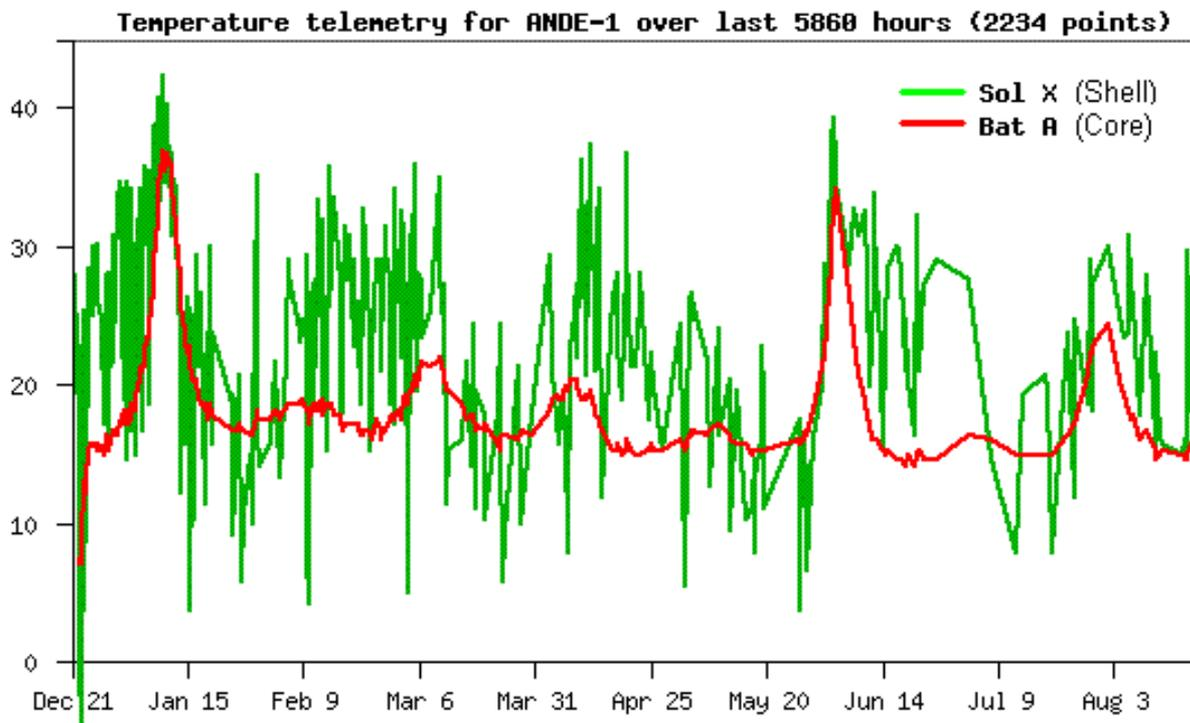



Example SatNOGS Pass

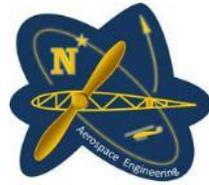

- BRICSat-2 and PSAT-2 are at low inclination, making contact from USNA difficult → distributed ground station networks are a huge help

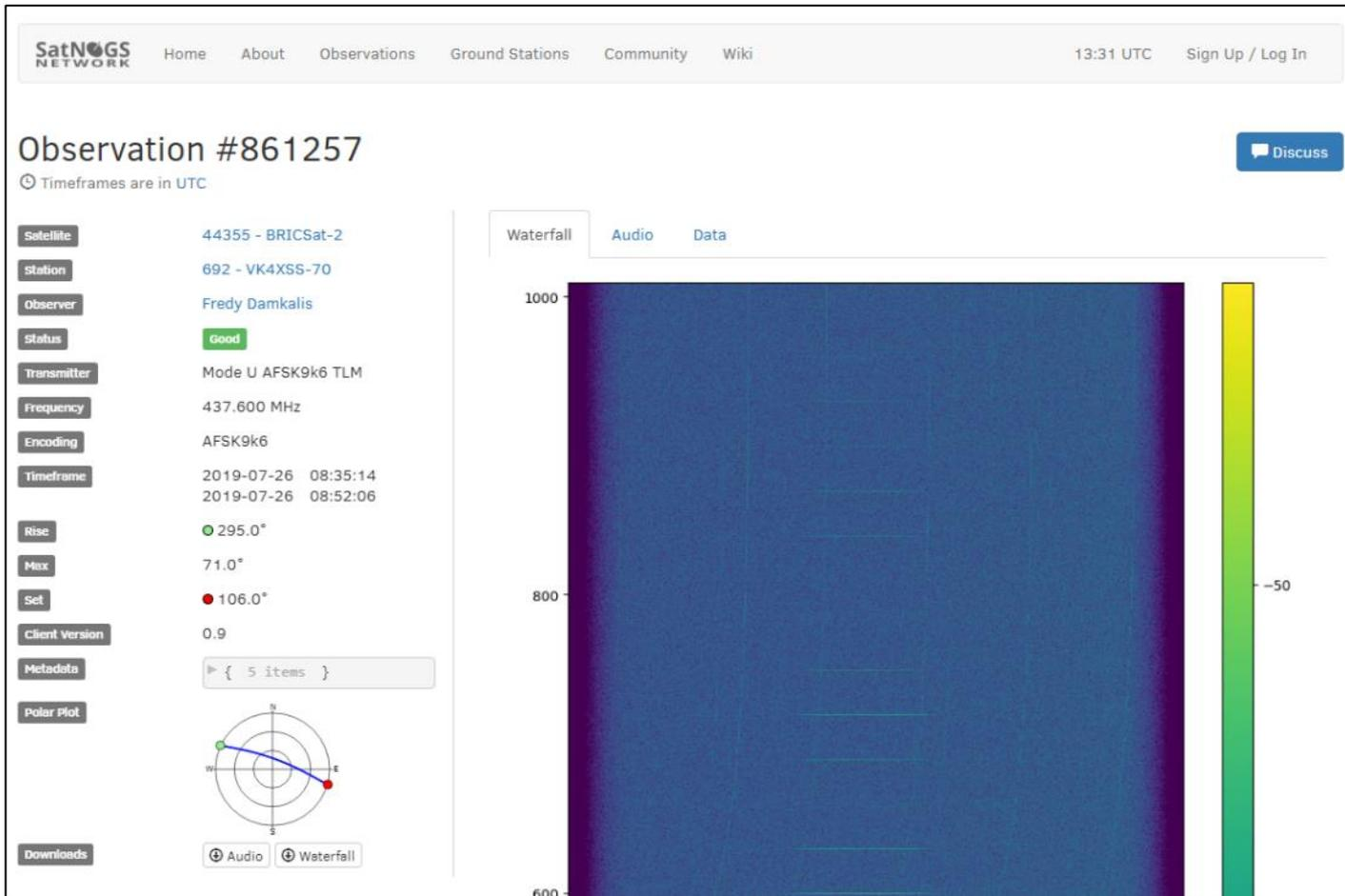



Another Great Source, findu.com

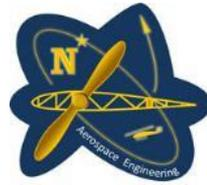

```
20191106133447,USNAP1-1>APOFF,ARISS,qAR,VK6HAM-2:>Bank0-SAFE
20191106133655,USNAP1-1>APOFF,ARISS,qAR,VK6HAM-2:T#252,729,000,000,000,669,01000100
20191106133857,USNAP1-1>APOFF,ARISS,qAR,YF1ZQA-10:T#254,725,000,000,000,669,01000100
20191106140858,USNAP1-1>APOFF,ARISS,qAR,N6DAN-1:T#002,729,000,000,000,670,01000100
20191106140958,USNAP1-1>APOFF,ARISS,qAR,N6DAN-1:T#003,725,000,000,000,671,01000100
20191106141059,USNAP1-1>APOFF,ARISS,qAR,N6DAN-1:T#004,718,000,000,000,670,01000100
20191106141153,USNAP1-1>APOFF,ARISS,qAR,N6DAN-1:>Bank0-SAFE
20191106141200,USNAP1-1>APOFF,ARISS,qAR,N6DAN-1:T#005,738,000,000,000,669,01000100
20191106141301,USNAP1-1>APOFF,ARISS,qAR,W0ARP-15:T#006,739,000,000,000,670,01000100
20191106141402,USNAP1-1>APOFF,ARISS,qAR,W0ARP-15:T#007,740,000,000,000,670,01000100
20191106141604,USNAP1-1>APOFF,ARISS,qAR,KC5ILO-12:T#009,750,000,000,000,670,01000100
20191106141705,USNAP1-1>APOFF,ARISS,qAR,KC5ILO-12:T#010,747,000,000,000,669,01000100
20191106141806,USNAP1-1>APOFF,ARISS,qAR,KE4AZZ-3:T#011,744,000,000,000,669,01000100
20191106142512,USNAP1-1>APOFF,ARISS,qAR,9Z4DZ-6:T#018,760,000,000,000,669,01000100
20191106142613,USNAP1-1>APOFF,ARISS,qAR,9Z4DZ-6:T#019,755,000,000,000,670,01000100
20191106151254,USNAP1-1>APOFF,ARISS,qAR,VK6HV-10:T#065,728,000,000,000,669,01000100
20191106151647,USNAP1-1>APOFF,ARISS,qAR,YF1ZQA-10:>Bank0-SAFE
20191106151759,USNAP1-1>APOFF,ARISS,qAR,YF1ZQA-6:T#070,725,000,000,000,669,01000100
20191106151900,USNAP1-1>APOFF,ARISS,qAR,YF1ZQA-10:T#071,724,000,000,000,669,01000100
20191106152101,USNAP1-1>APOFF,ARISS,qAR,YF1ZQA-10:T#073,723,000,000,000,670,01000100
20191106154955,USNAP1-1>APOFF,ARISS,qAR,KG6HSQ-2:T#007,745,000,000,000,670,01000100?
20191106155056,USNAP1-1>APOFF,ARISS,qAR,N6DAN-1:T#008,743,000,000,000,669,01000100
20191106155157,USNAP1-1>APOFF,ARISS,qAR,N6DAN-1:T#009,737,000,000,000,670,01000100
20191106155246,USNAP1-1>APOFF,ARISS,qAR,N6DAN-1:>Bank0-SAFE
20191106155258,USNAP1-1>APOFF,ARISS,qAR,N6DAN-1:T#010,751,000,000,000,670,01000100
20191106155358,USNAP1-1>APOFF,ARISS,qAR,N6DAN-1:T#011,753,000,000,000,670,01000100
20191106155459,USNAP1-1>APOFF,ARISS,qAR,N6DAN-1:T#012,742,000,000,000,670,01000100
20191106155601,USNAP1-1>APOFF,ARISS,qAR,KC5ILO-12:T#013,753,000,000,000,670,01000100
20191106155745,USNAP1-1>APOFF,ARISS,qAR,KC5ILO-12:>Bank0-SAFE
20191106155802,USNAP1-1>APOFF,TCPIP*,qAR,KE4AZZ-4:T#015,752,000,000,000,669,01000100
20191106155903,USNAP1-1>APOFF,TCPIP*,qAR,KE4AZZ-4:T#016,754,000,000,000,669,01000100
20191106160004,USNAP1-1>APOFF,TCPIP*,qAR,KE4AZZ-4:T#017,746,000,000,000,670,01000100
```

Captures every Telemetry or data packet heard anywhere



Enabler for Other Student Projects

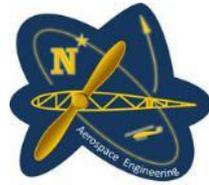

- Having data relay transponders in space enables other remote-sensing student projects
- Ex) Ocean and Arctic Buoy





Challenges of Working with Students



- Operational vs. educational
 - Naval Academy Small Satellite Program does not develop operational satellite
 - Only and main goal is student education and training – may result in some undesirable programmatic consequences
 - Working to launch deadline may not be the best model
 - Scope of mission can often change
 - Reliability not necessarily main concern
- Grades/incentive can only go so far
 - Building something that will fly in space is very cool
 - ... but students have priorities and obligations
 - Conferences and external sponsors serve as great motivator
 - ... but if students decide to “give up”, not much can be done

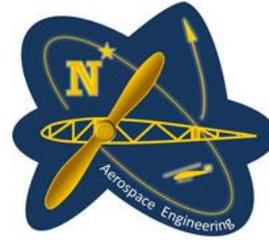

Lessons Learned: Satellite System and Low Tech Solutions



Documentation

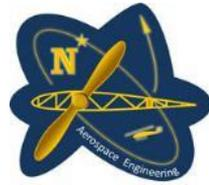

- Documentation is very important
 - Everyone knows this, but students don't "feel it" until it is too late
 - Difficult to encourage students to follow good documentation practices
- My solution: force them to do it anyway with good templates
 - Providing templates, list of docs I want, and details help them produce decent documentation
 - Still don't know why they are doing it... BUT they DO appreciate it later

Students:

"What is this materials list thing. Seems like a lot of unnecessary busy work. I want to start building..."

First telecon with NASA Launch Coordinators:

"Can you send us your materials list so we can prevent any potential issues right away?"

Students:

!!!



Pictures of Everything

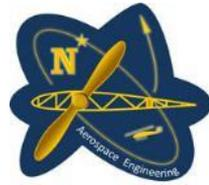

- Take pictures of everything!
- Take pictures of everything!
- More importantly, upload them immediately with proper labels so they can be found/traced later
- It may save you a lot of time and effort later on
 - When critical information has not been documented, pictures can be very useful in proving positive/negative
 - Very helpful in generating documents

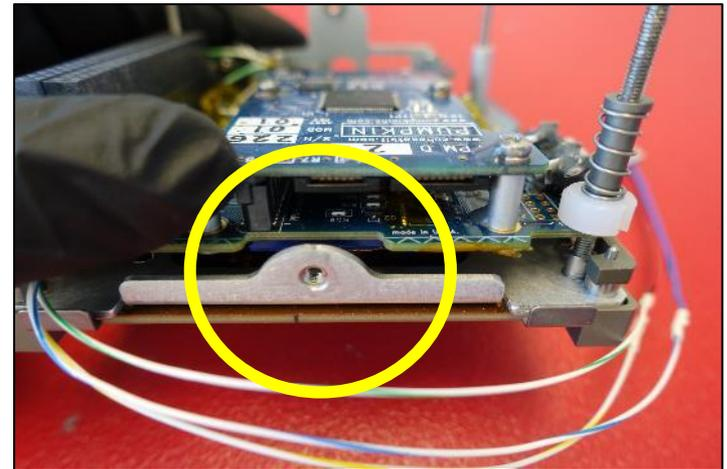



Distributed C&DH

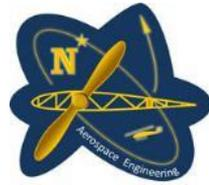

- Main computing based on microcontroller
 - Low power
 - All we need
 - Great for satellite command managing and house keeping
- But has drawbacks
 - Technology moves ahead at a fast pace
 - C language microcontroller programming too much for non-software engineers
- USNA's solution: Arduino minis
 - Very easy for students to learn on
 - Each subsystem that requires any kind of processing uses an Arduino mini
 - Then each subsystem communicates with the main processor (microcontroller) at very high level
 - Plenty of libraries for peripherals

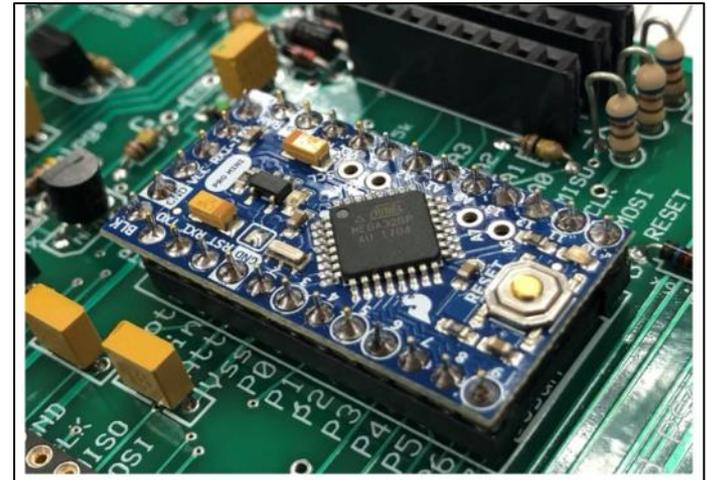



Electronics Shrink, But Benefit to Big Parts

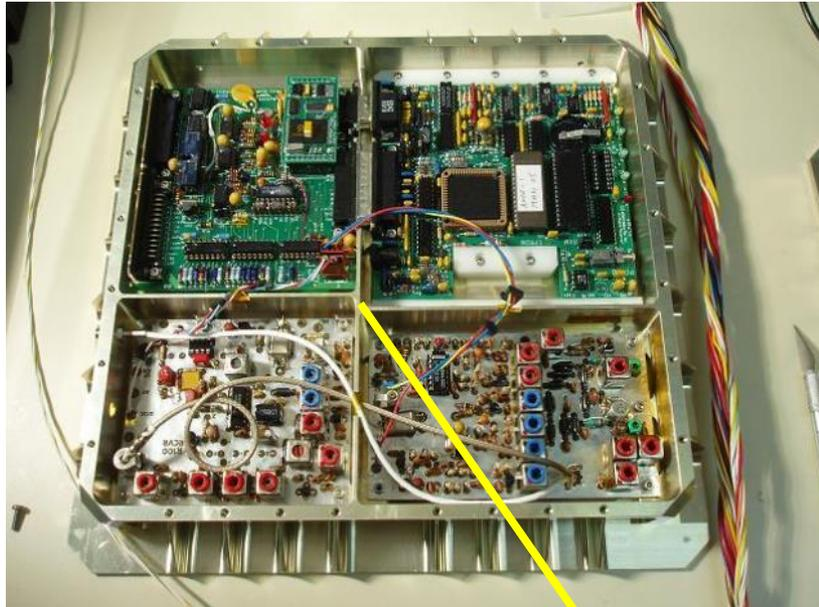
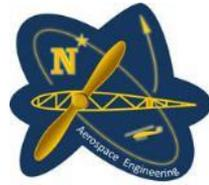

Earlier reductions to 5" cubesat on RAFT (2006)

4:1

Now reduced 18:1 in volume/mass for 4" cubesat

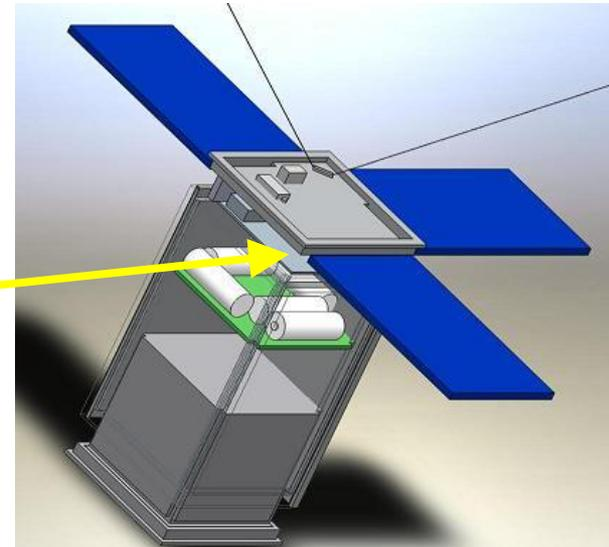



For Student Built Satellites, Big is Good

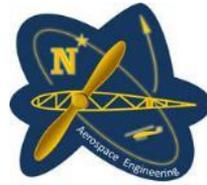

- Easy Through-hole parts for components to be soldered
- Easy to troubleshoot/repair





Multiple Reset Schemes

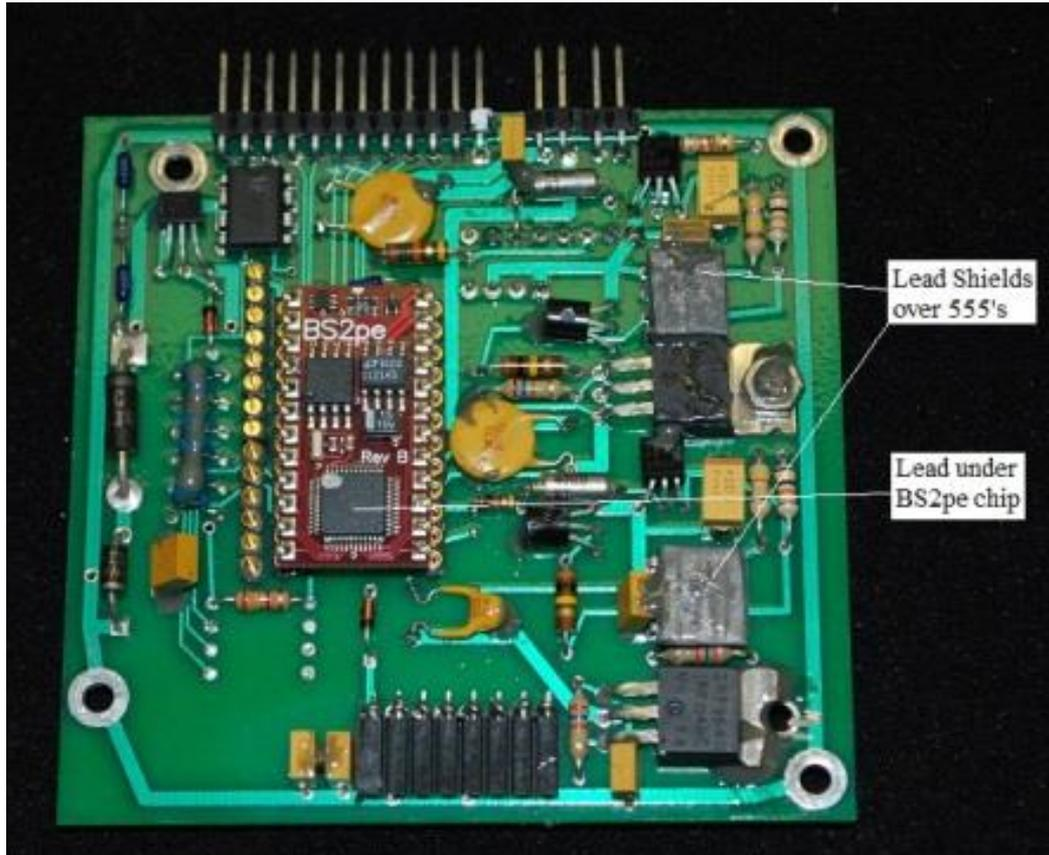
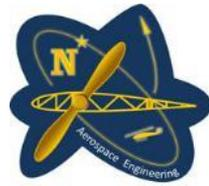

Multiple Resets:

- 555 Watchdog

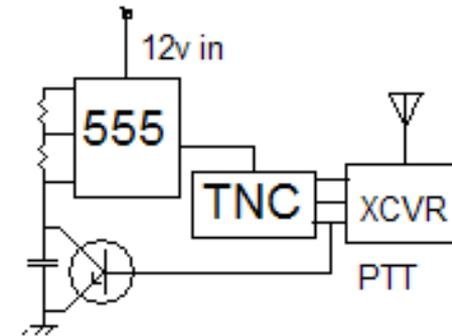

- Command bit
- 5 day timeout
- Second RX
- Touchtone

Lead shields over CPU, RAM and other critical dies



Radiation Shielding Also Considered

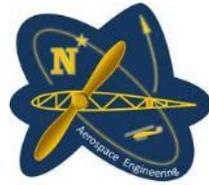

- CubeSats do not have the luxury to put ¼” AL casing around the components
- ... pieces of lead only on critical chips?

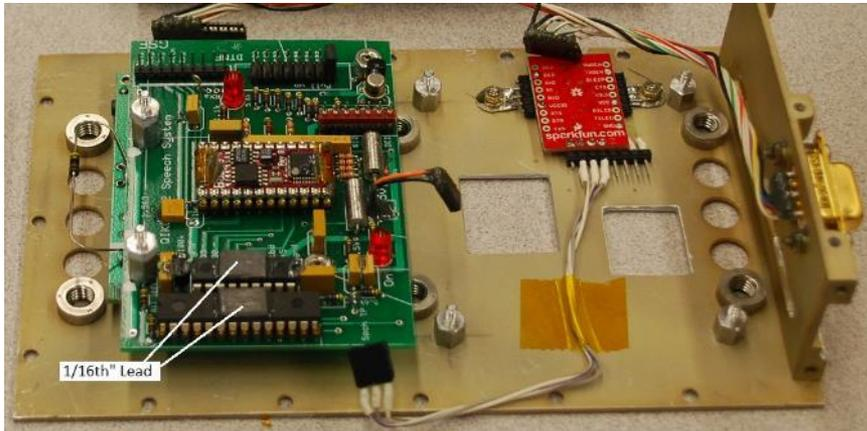

Radiation Shielding (Lead vs Tantalum)

Top and bottom of CPUs, RAMS
And EEPROMS





Now Too Light...

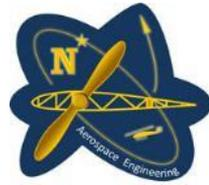

- Most of our new satellites are below mass limits
- Ballast is good to keep satellite longer in orbit

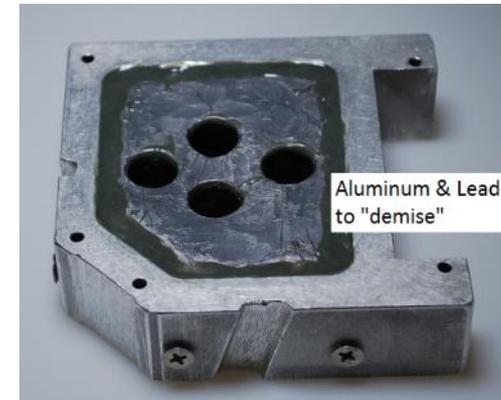
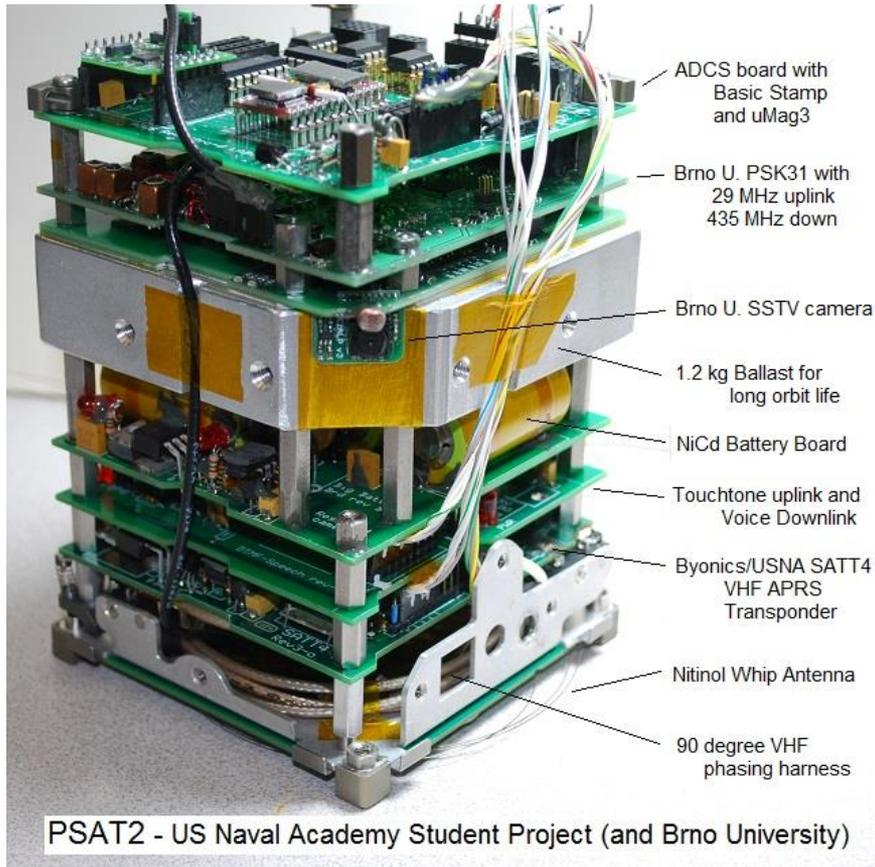

1.2 kg Ballast for long life



Never Leave Bakeout Unattended

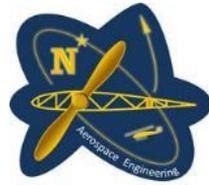

Never leave
flight hardware
unattended....

Especially in a
“found” thermal
chamber with
cord cut off...



Value of LEDs – (and use of corners)

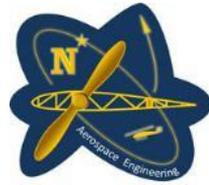

- Why do you need LEDs in space?
 - You don't, but they are hugely helpful on ground
- May result in huge resource saving

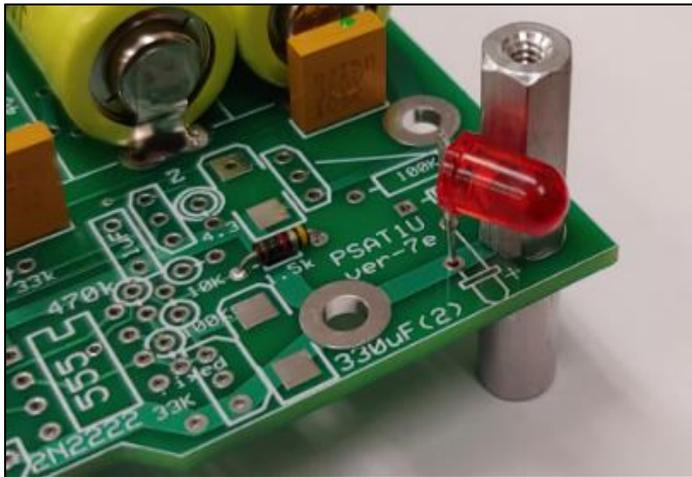

Troubleshooting LED
view ports

Rails are great places for space ports
Without disturbing solar panels

Camera
Port





Very simple Antenna Release

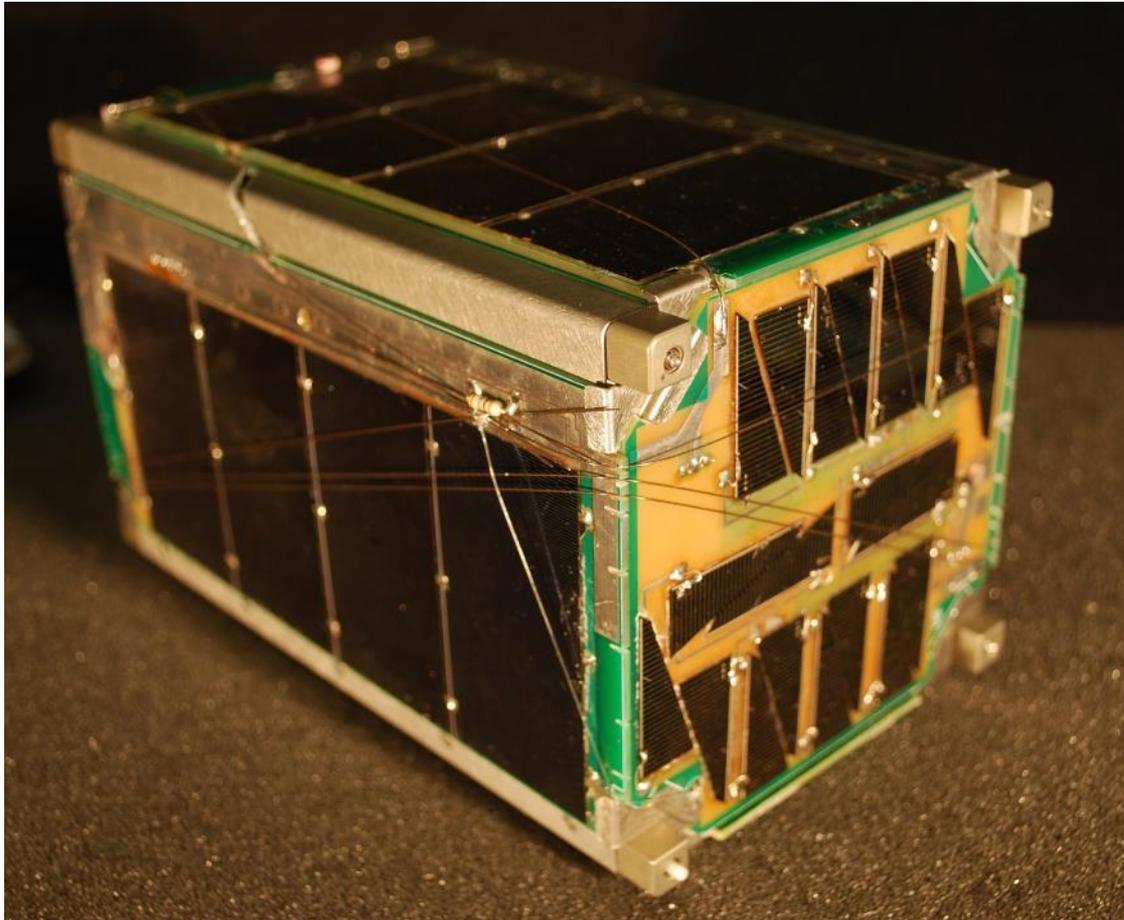
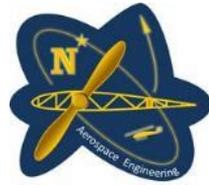

One burn resistor releases 5 Antennas:

-2 Orthogonal UHF whips

-2 orthogonal VHF whips

-One 6' HF whip

Solder pads provided on all solar panels for final location determination after all antennas tuned.

(Offset Solar panels provide 6 to 10 RPM spin)



Debris-catching



- Conformal coating is great
- All big components staked with epoxy
- Helps to have debris catching tape

Conformal Coating (just cover with tape)

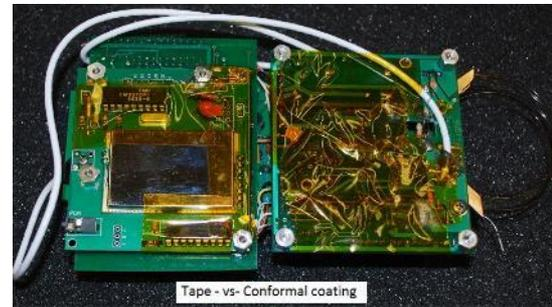

Debris catching (Double sided tape)



RF Testing in the Lab

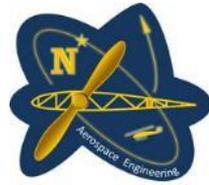

- Signals can “jump over” attenuators plugged back-to-back

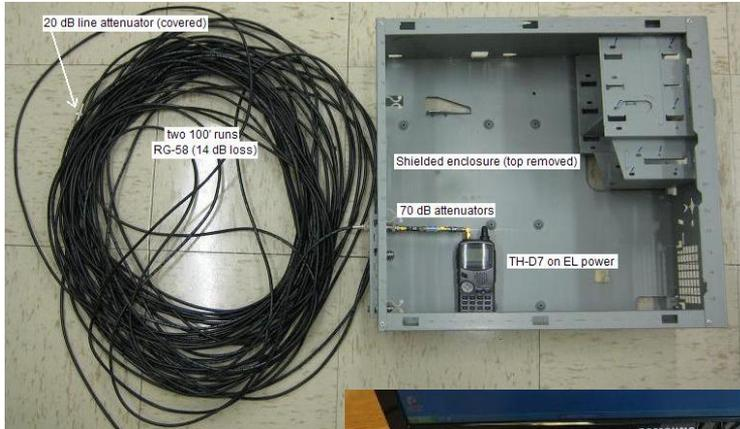

“Bench top Testing”

=

200' Room-to-Room
And around corner

Distributed
100 dB
Attenuation

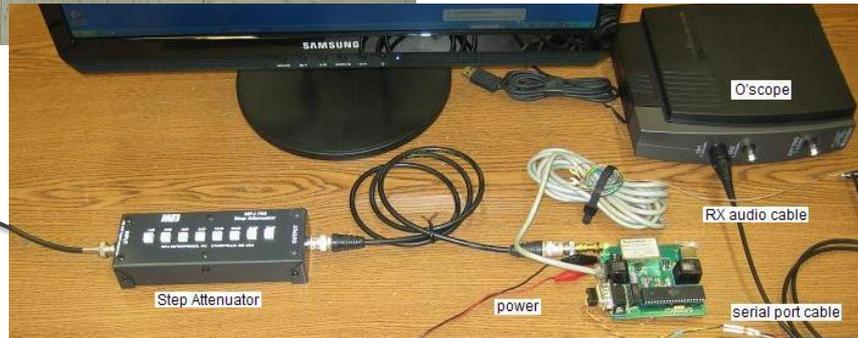

Even with Dummy Load on TX, still 5 mW is still radiated from radio!
Only 35 dB attn...



Final RF test includes Antennas

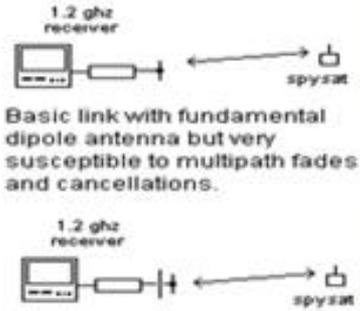
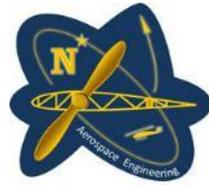

Adding a reflector off the back of the dipole gives 3 dB gain and possibly better viewing by eliminating half of the multipath reflections.



RF path of 1 mile test and 60 dB attn.

Same as 1000 mile LEO path



Give Students Early Experience

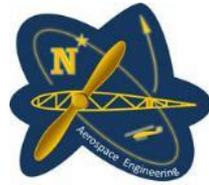

- Underclass students make satellite contact the “old fashioned way”
 - Tuning manually with dial – following Doppler
 - Aiming manually with AZ-EL controls
- Helps them develop a sense for what a good signal feels like

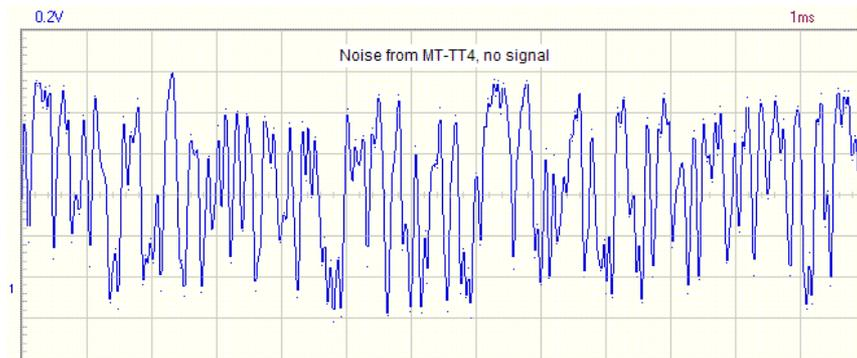

16 dB S/N
95% decode

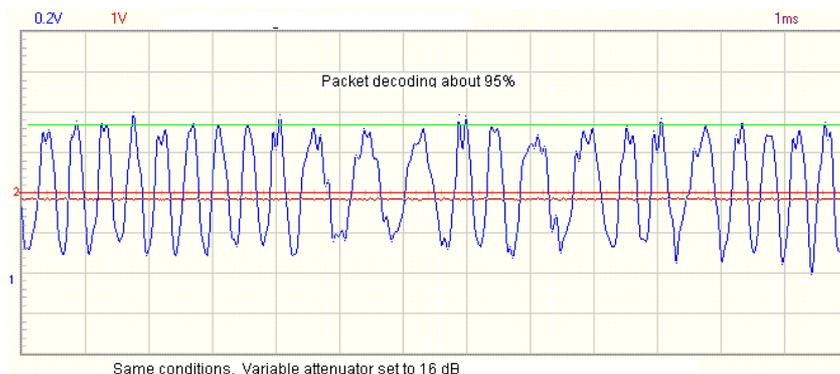

Does it look right?

Does it sound right?





Closing Remarks

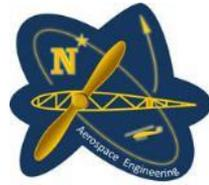

- Even for CubeSat-class satellites, standardization is hard
 - Hard to lock down design with landscape changing too fast
- Naval Academy Small Satellite Program developed a USNA standard bus geared towards student education
 - Quick development cycle
 - Unique approach, different from higher-capability, more compact design
- Students are still students: challenges are there, but we have some good practices
 - Operate – then – Conceive, Design, Implement
- Amateur radio a critical component to student projects
 - Easier access to hands-on experience
 - Teach them to be practical engineers
- Certain lower-tech, but more-robust design features can greatly benefit student satellite development experiences
 - You can truly let students break flight hardware – more learning opportunities



Thank you.
Questions?

