

National Aeronautics and  
Space Administration



# Forward to the Moon with Artemis

.....  
**EXPLORER ACTIVITIES**

Ages 5-12





# EXPLORE MOON *to* MARS

As the nation celebrates the 50th anniversary of the Apollo Moon landing on July 20, 2019, NASA has its sights set on traveling forward to the Moon—

*this time to stay!*

NASA's new Artemis mission will land the first American woman and the next American man on the surface of the Moon by 2024.

## Activity Ratings:

- ★ easiest
- ★★ more challenging
- ★★★ most challenging

APOLLO  
50  NEXT GIANT LEAP



# Lunar Exploration

Find and circle 10 differences between the two images.

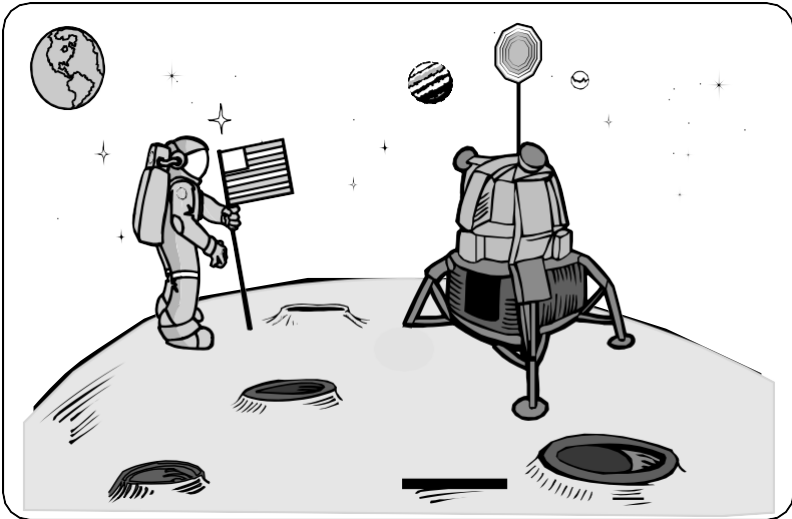
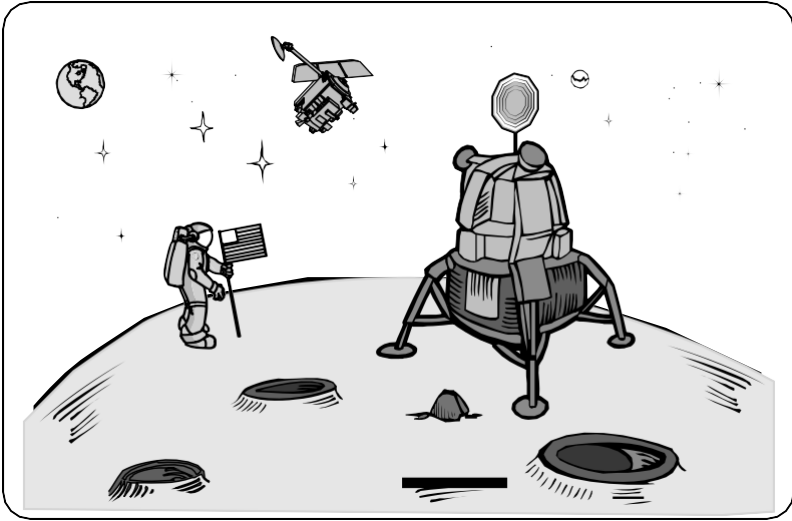

**Celebrating 50 Years of Apollo**  
and looking forward to  
**Artemis, the Next Era of Space Exploration**



# The Artemis Generation

Complete the word cloud by writing words that represent what it takes to get to the Moon by 2024 inside the dashed boxes.



**Artemis** was the *twin sister of Apollo* and the *goddess of the Moon* in Greek mythology.

**Artemis** is the name of NASA's ambitious program to land humans on the ***Moon by 2024***.





# Landing at the Moon's South Pole

*Jot down your ideas of why NASA chose the South Pole for the 2024 Artemis landing site.*

The South Pole of the Moon has a lot of water ice. Some areas of the South Pole receive over 200 Earth days of continuous sunlight.

---

---

---

---

---

---

---

---

---

---

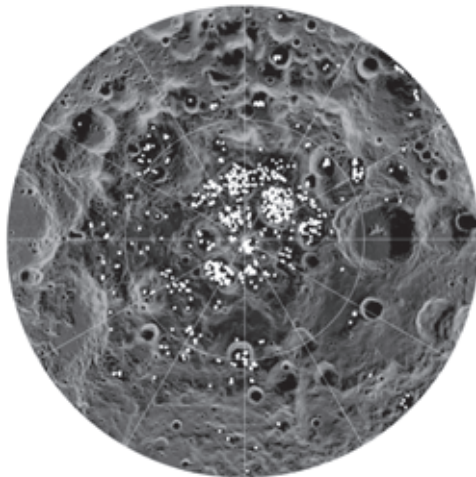

The light spots represent water ice on this satellite image of the Moon's South Pole.

# Coding Takes You Everywhere

Fill in the blanks 0's and 1's to complete the pattern.

<b>0</b>	0 0 0 0	<b>8</b>	1 0 0 0
<b>1</b>	0 0 0 1	<b>9</b>	1 0 0 _
<b>2</b>	0 0 1 0	<b>10</b>	1 0 1 0
<b>3</b>	0 0 1 1	<b>11</b>	1 _ 1 1
<b>4</b>	0 1 0 0	<b>12</b>	1 _ 0 0
<b>5</b>	0 1 _ 1	<b>13</b>	_ 1 0 1
<b>6</b>	0 1 1 0	<b>14</b>	1 1 1 _
<b>7</b>	_ 1 1 1	<b>15</b>	1 1 1 1

Binary code uses 0's and 1's to represent letters and numbers.  
It allows people on Earth to talk to astronauts in space.

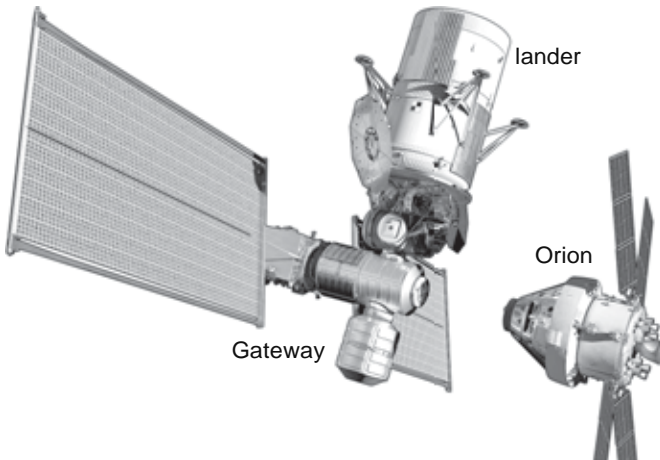

Artemis astronauts will travel in Orion to the Lunar Gateway. The lander will shuttle astronauts to the surface of the Moon. More parts will be added to the Gateway over time.





# Decode the Binary Message

Using 0's and 1's, complete the binary code for capital letters.

<b>A</b>	01000001	<b>N</b>	_100_110
<b>B</b>	01000010	<b>O</b>	010011__
<b>C</b>	010_0011	<b>P</b>	01010000
<b>D</b>	01000100	<b>Q</b>	01010_01
<b>E</b>	010001__	<b>R</b>	0101001_
<b>F</b>	01000110	<b>S</b>	01010011
<b>G</b>	0_0_0111	<b>T</b>	010_010_
<b>H</b>	01001000	<b>U</b>	01010101
<b>I</b>	01001_0_	<b>V</b>	01010_10
<b>J</b>	01001010	<b>W</b>	01010_11
<b>K</b>	_10_1011	<b>X</b>	01011000
<b>L</b>	01001100	<b>Y</b>	01_11_01
<b>M</b>	01001101	<b>Z</b>	01011010

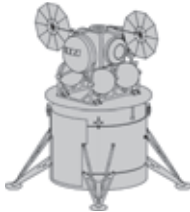

Lander



Rover

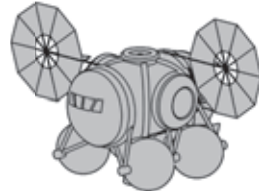

Ascent Vehicle

Use the code to reveal the message.

01001010

01001111

01001001

01001110

01010100

01001000

01000101

01000001

01010010

01010100

01000101

01001101

01001001

01010011

01001101

01001001

01010011

01010011

01001001

01001111

01001110



# Apollo Command and Service Module

*Connect the dots.*

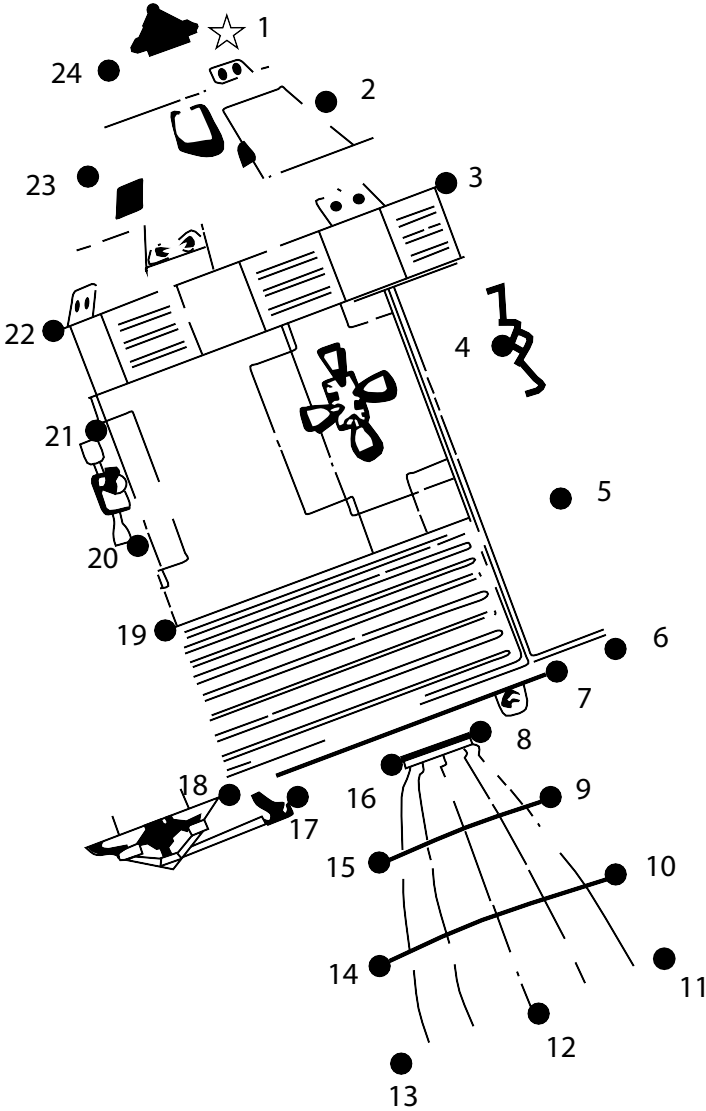

Carried Apollo astronauts from Earth to lunar orbit and back to Earth.





# Apollo Lunar Modules

Circle the two identical Lunar Modules.

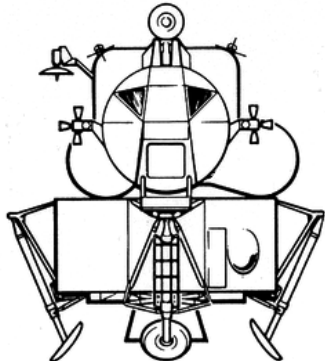
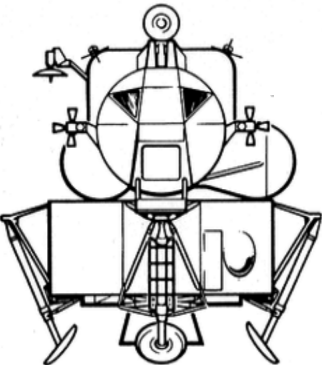
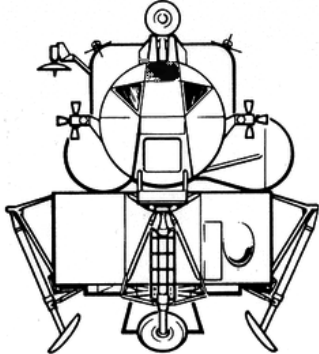
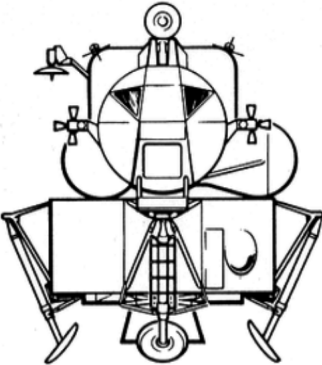
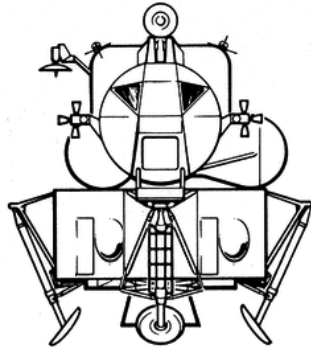
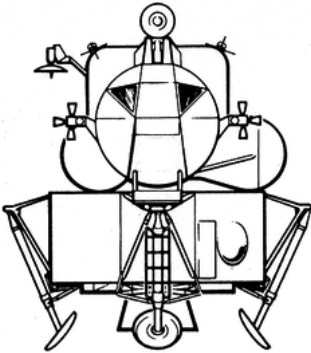

Carried Apollo astronauts from the Command and Service Module to the surface of the Moon and back. Also called the LEM (Lunar Excursion Module).



# Space Explorer Puzzle

Fill in the empty squares. Each of the shapes should appear once in each row, column, and two-by-two block.

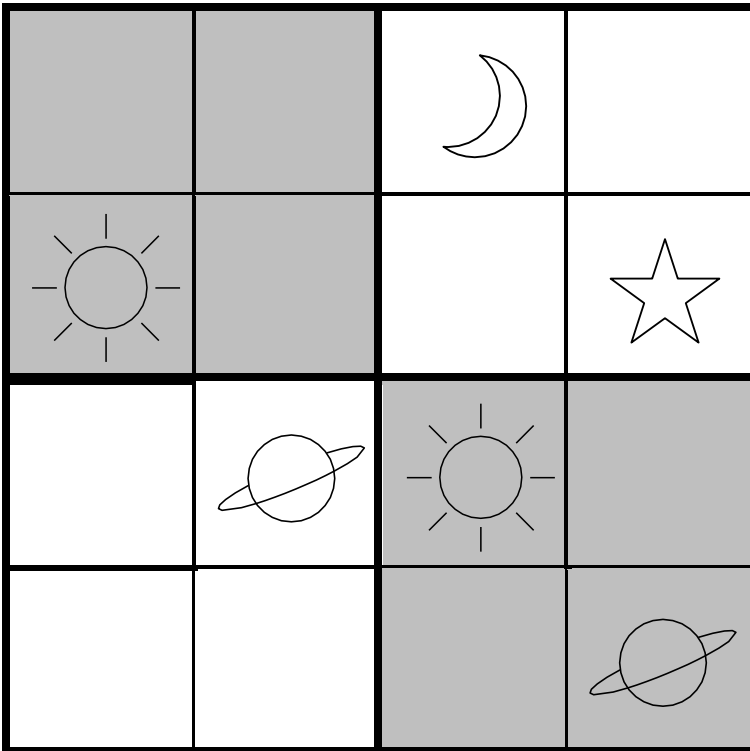
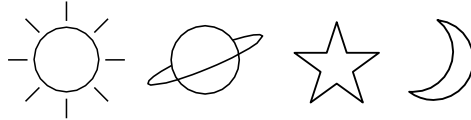

## Did You Know?

On July 20, 1969, Neil Armstrong became the first person to walk on the surface of the Moon?

To date, 24 humans have visited the Moon and 12 have walked on its surface.





## Continuous Path

*Trace the shape below with one continuous line.  
Do not retrace any lines, do not add new ones.*

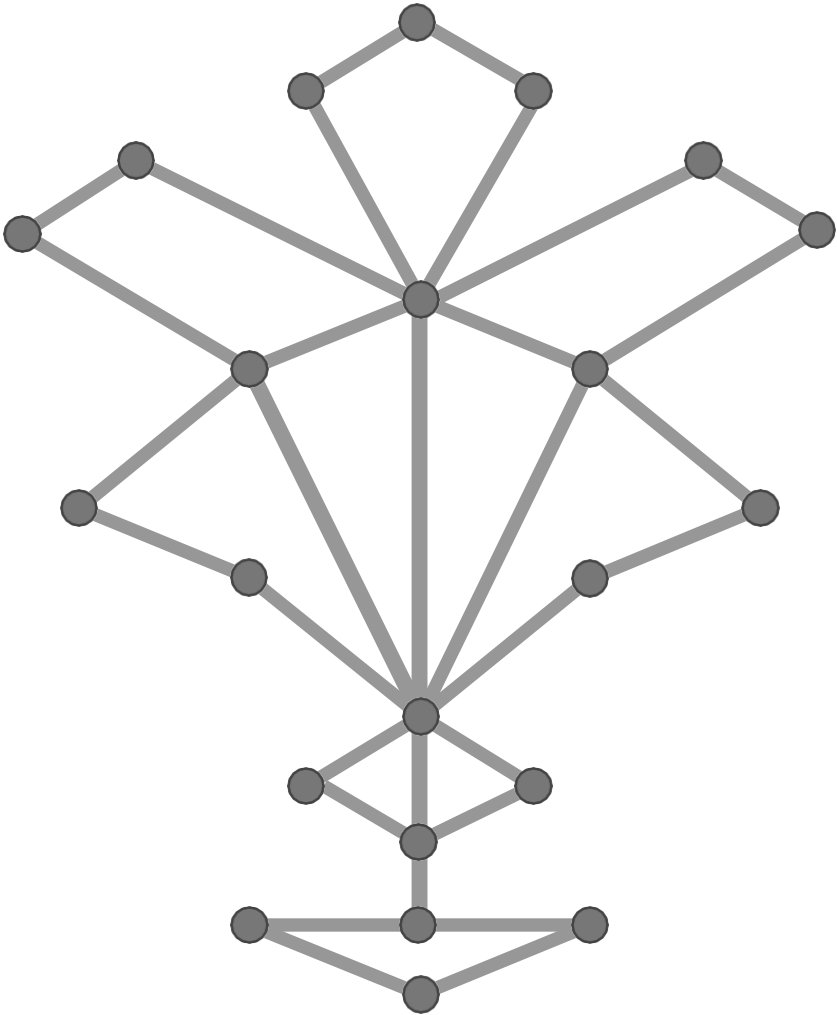

“That’s one small step for a man, one giant leap for mankind.”

First words spoken from the  
surface of the Moon.

Neil Armstrong, July 20, 1969.



# Forward to the Moon and on to Mars

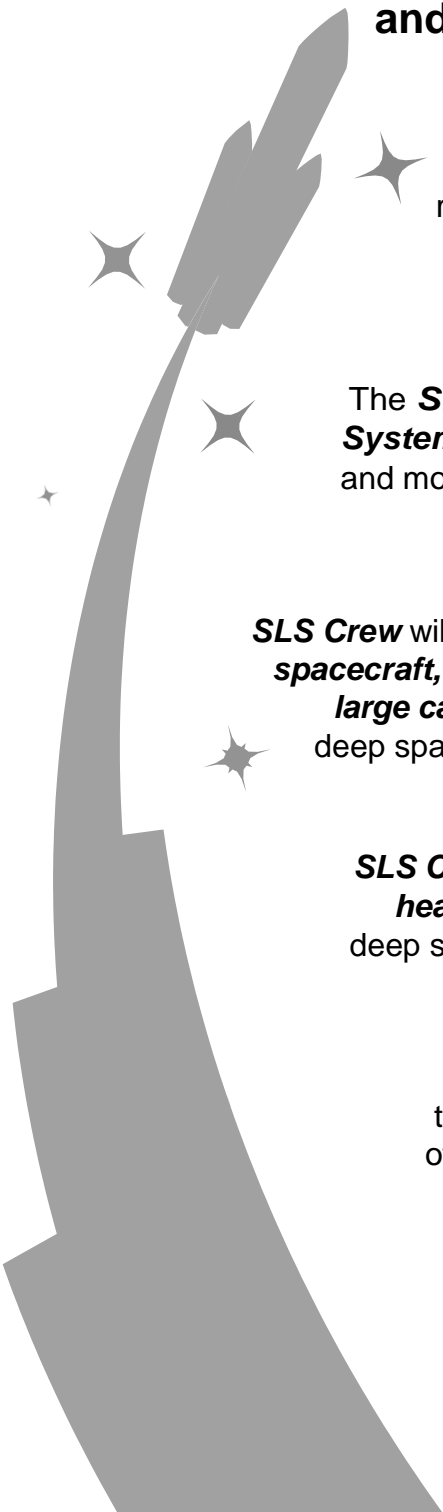

Traveling to the ***Moon*** and ***Mars*** requires ***powerful rockets.***

The ***SLS (Space Launch System)*** is NASA's ***newest*** and most ***powerful rocket.***

***SLS Crew*** will transport the ***Orion spacecraft, astronauts,*** and a ***large cargo supply*** to deep space destinations.

***SLS Cargo*** will launch ***heavy cargo*** to deep space destinations.

***SLS*** will provide the power to help Orion reach a ***speed*** of at least ***24,500 miles per hour*** needed to break out of ***low-Earth orbit.***



# NASA's Newest Rockets

*Color SLS Crew and SLS Cargo.*

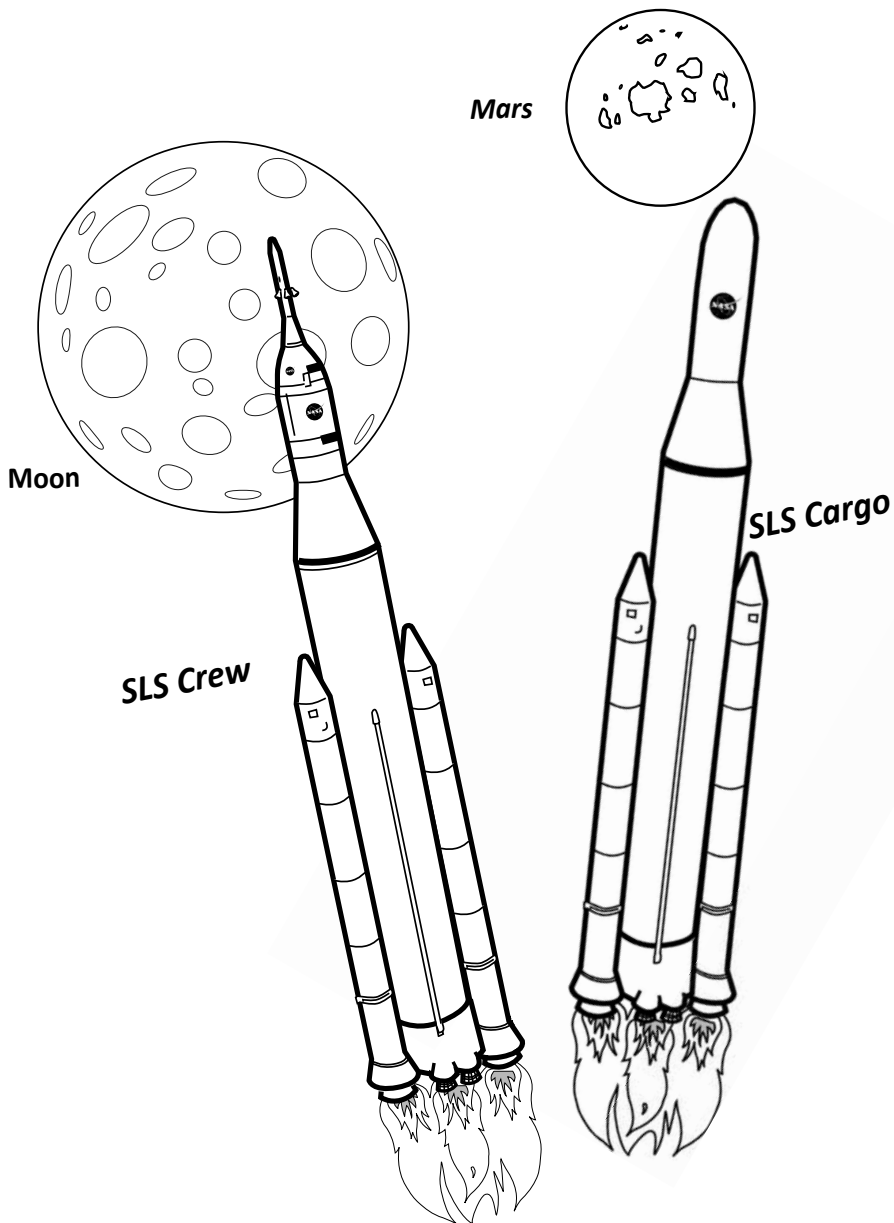

## NASA's Next Human Spacecraft

*Match the words on the opposite page to the clues below to reveal the name of NASA's next human spacecraft.*

1. NASA is building the Lunar Gateway, a new spaceship that will orbit the:
2. The Space Launch System has two types of rockets, one for heavy cargo and one for:
3. Satellites show the Moon's North Pole has large amounts of water stored as:
4. The Space Launch System will be NASA's newest and most powerful:
5. The Latin word for Moon is:



1. 

--	--	--	--

2. 

--	--	--	--	--

3. 

--	--	--	--

4. 

--	--	--	--	--	--	--

5. 

--	--	--	--

ice   luna   crew   Moon   rocket

The \_\_\_\_\_ spacecraft will launch atop the  
Space Launch System and take humans  
farther into space than ever before.

# Providing Power for the SLS

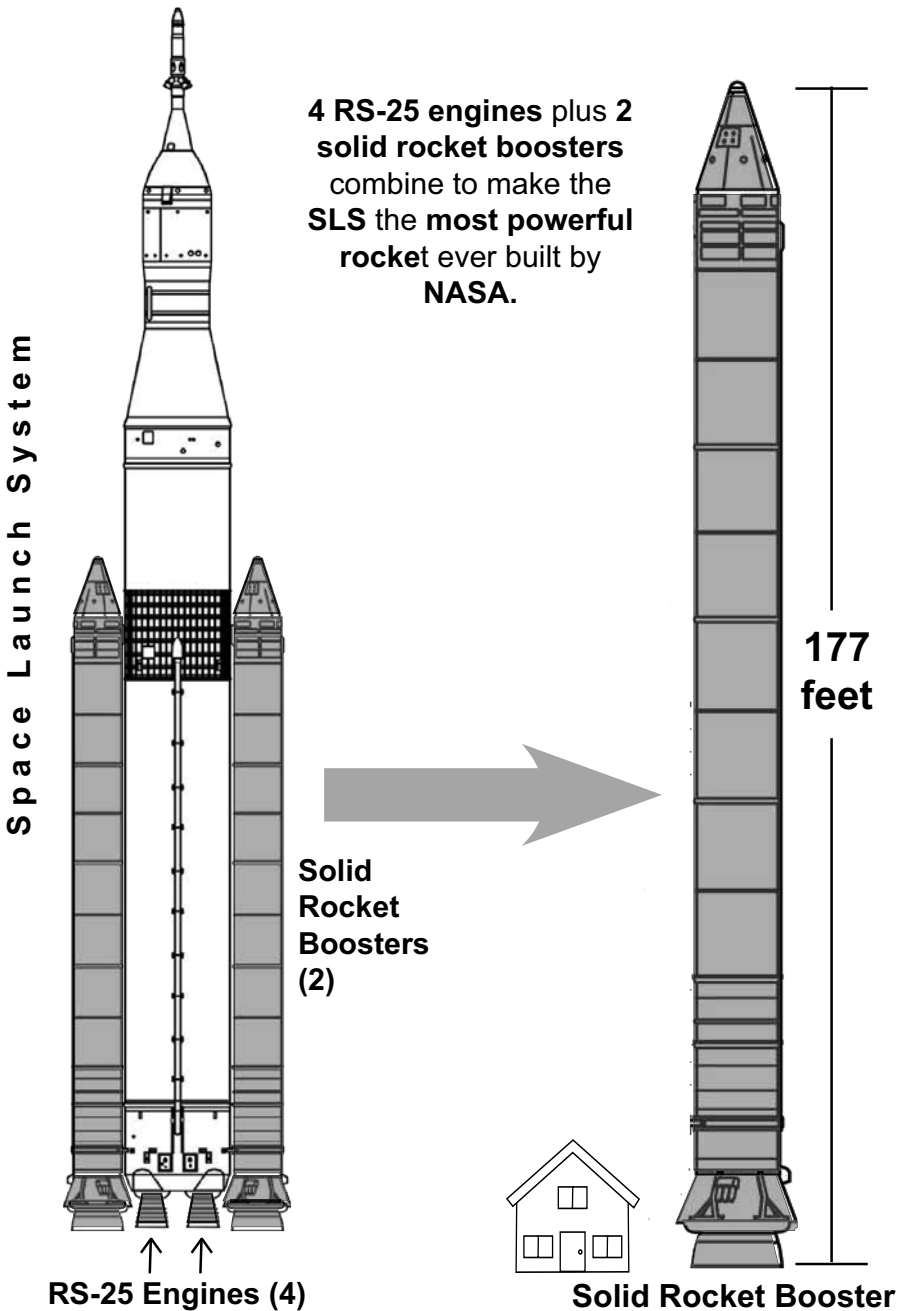



If the average house is **20 feet tall**, about how many houses could be stacked on top of each other to reach the height of the solid rocket booster?

Answer: \_\_\_\_\_

If the average astronaut is **6 feet tall**, about how many astronauts could stand on top of each other to reach the height of the RS-25 engine?

Answer: \_\_\_\_\_

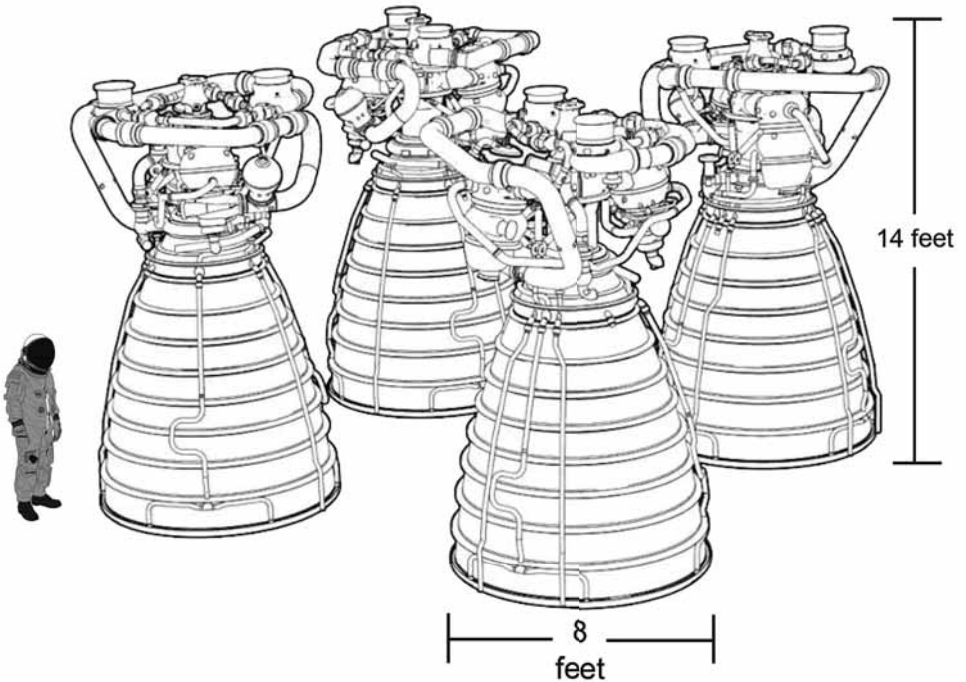

**RS-25 Engines**

# Make New Words

Make as many words as you can from the letters in:

**P R O P U L S I O N**

2-3 letter words:

_____	_____	_____
_____	_____	_____
_____	_____	_____
_____	_____	_____

4 letter words:

_____	_____	_____
_____	_____	_____
_____	_____	_____

5 letter words:

_____	_____	_____
_____	_____	_____
_____	_____	_____

6 letter words:

_____	_____	_____
-------	-------	-------

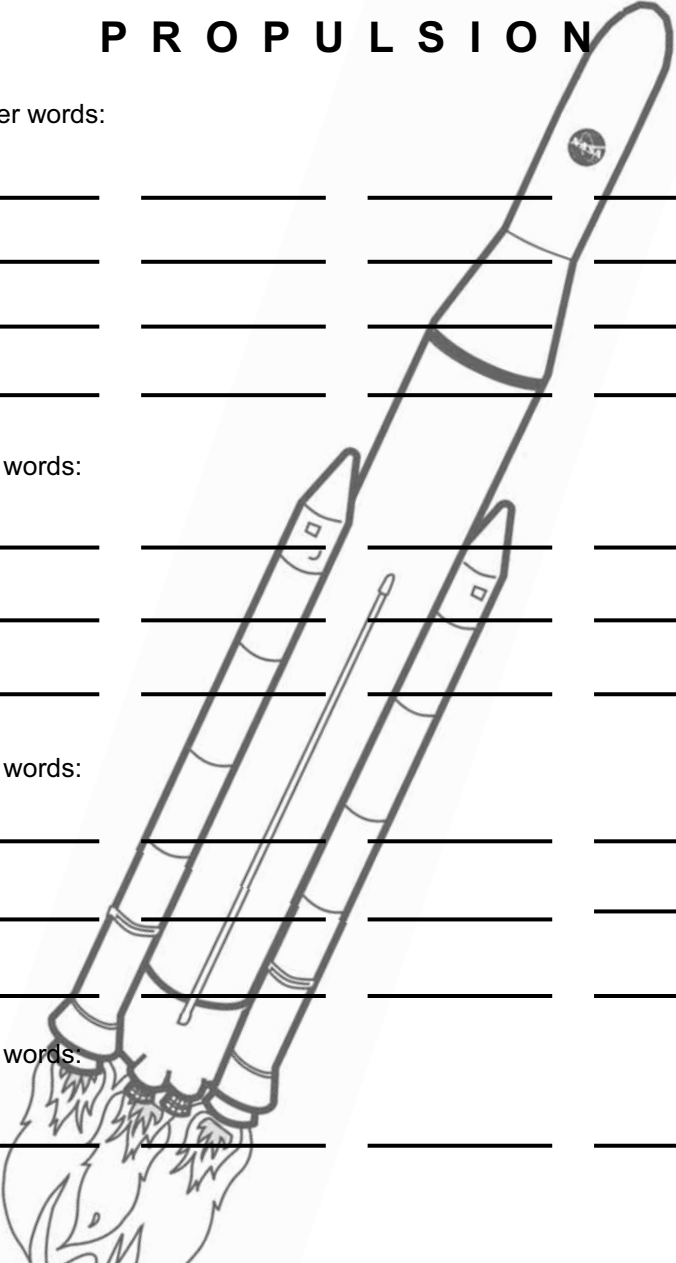

**PROPULSION** - to drive an object forward.

# Lunar Gateway

NASA is working with its partners to design and build the Lunar Gateway, a small spaceship that will orbit the Moon.

Astronauts will live and work in the Gateway for several months at a time. They will travel to the surface of the Moon and explore how the Moon can help astronauts travel to Mars.

Living in the Lunar Gateway will help astronauts learn how to survive in deep space and prepare for future expeditions to Mars.

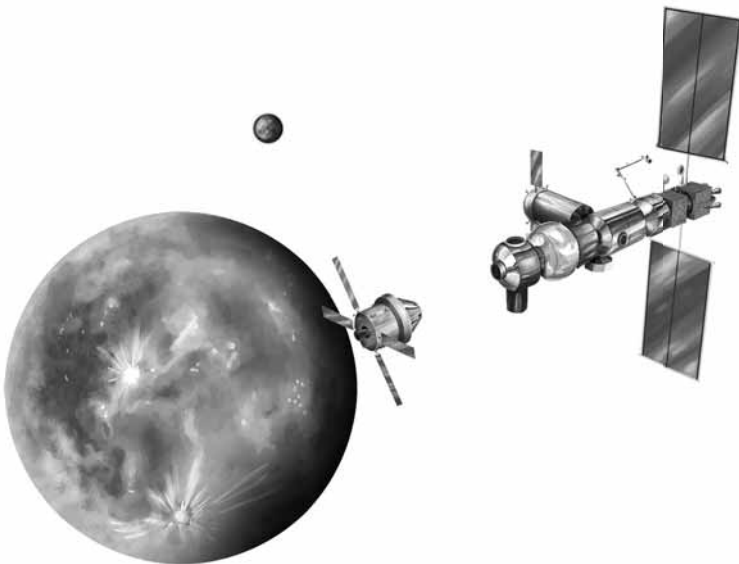

# Living and Working in Space

Match each part of the Lunar Gateway on the opposite page to the assembled model below. Write the letter of each part in the correct boxes.

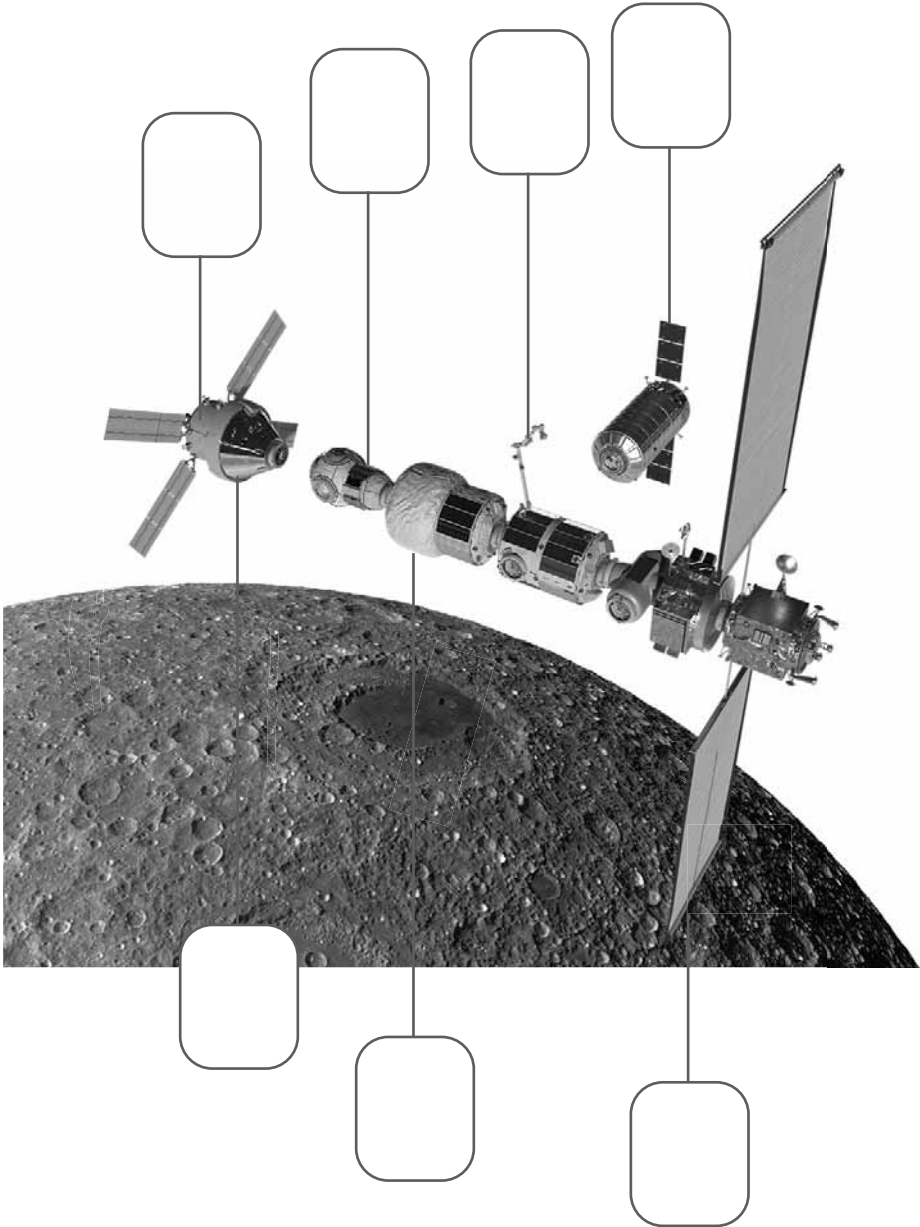



A

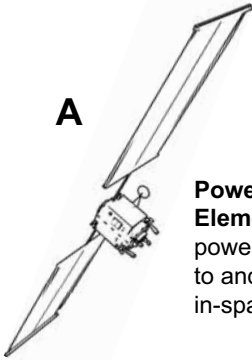

**Power and Propulsion Element.** Provides power, communication to and from Earth, and in-space transportation.

B



**Robotic Arm.** Mechanical arm to help spacecraft dock to the Lunar Gateway.

C

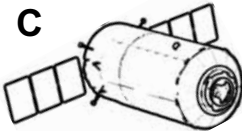

**Cargo Resupply.** Delivers food and other cargo to the Lunar Gateway.

D



**Orion Spacecraft.** Transports astronauts deeper into space than ever before.

E

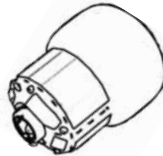

**Habitation Module.** Where astronauts will live and work.

F



**Airlock.** Airtight room with two entrances that allow astronauts to go on a spacewalk without letting air out of the spacecraft.

G

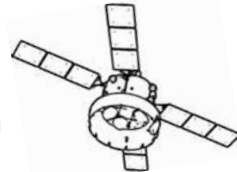

**Orion Service Module.** Supplies electricity, propulsion, temperature control, and the air and water needed for space travel.

# Destination: Lunar Gateway

*Help Orion Get to the Lunar Gateway.*

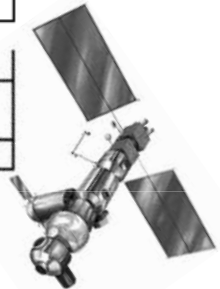
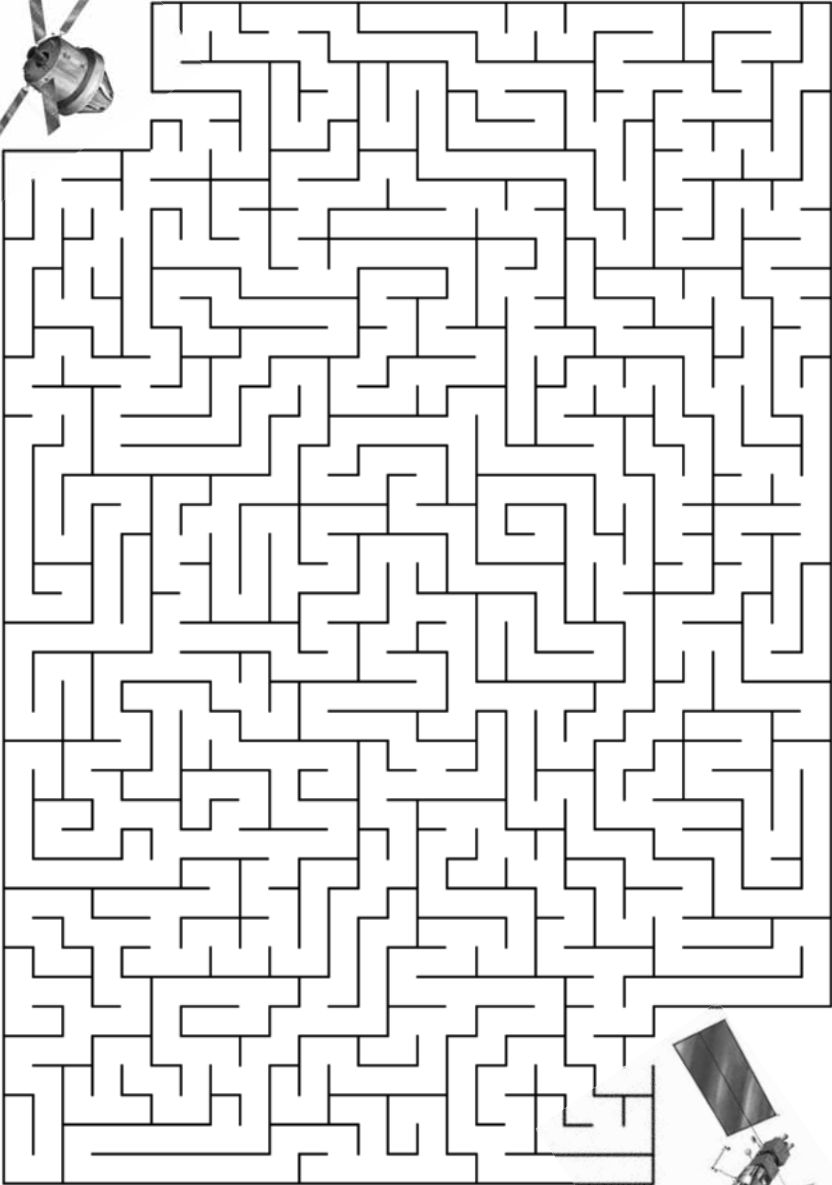

# How Many Triangles?

How many triangles are in the drawing below?

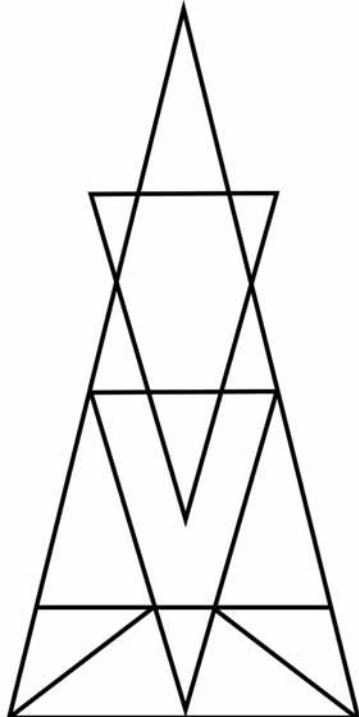

There are \_\_\_\_\_  
triangles.

*Triangles provide strength and stability and are often used in the design of buildings, launchpads, and other structures.*









# Complete the Pattern

Draw the picture that comes next in each row.

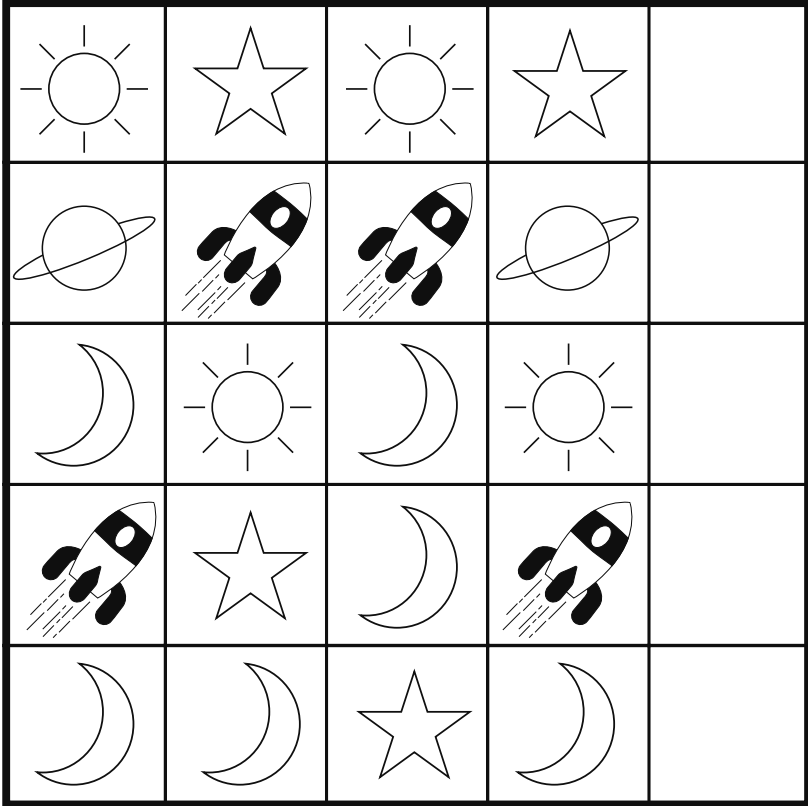

# Space Haiku

Create a haiku. Use the words below or choose your own.

A haiku is a poem with three lines.

The first line has five syllables. The second line, seven.

The third line has five syllables.

space  
galaxy  
solar  
launch  
surface  
wonder  
mission

gateway  
stars  
system  
rocket  
challenge  
astronaut  
Artemis

explorer  
liftoff  
challenge  
Moon  
explore  
Mars  
human

life  
frontier  
Orion  
planet  
lunar  
unknown  
quest

*Title*

*5 syllables*

*7 syllables*

*5 syllables*

# Lunar Gateway Orbit

Determine the distance between the Moon and the Lunar Gateway.

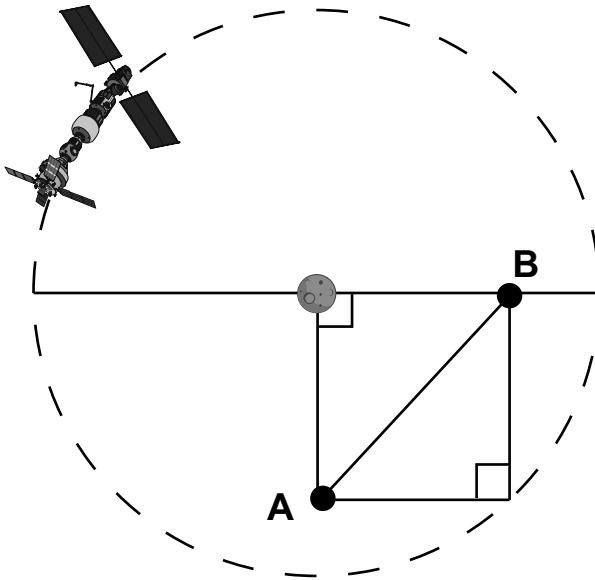

The Lunar Gateway is in a circular orbit around the Moon. If the distance between point A and point B is 930 miles, what is the distance between the Moon and the Lunar Gateway?

The Lunar Gateway is \_\_\_\_\_ miles from the Moon.

# Orion Maze

*Help Orion find Mars.*

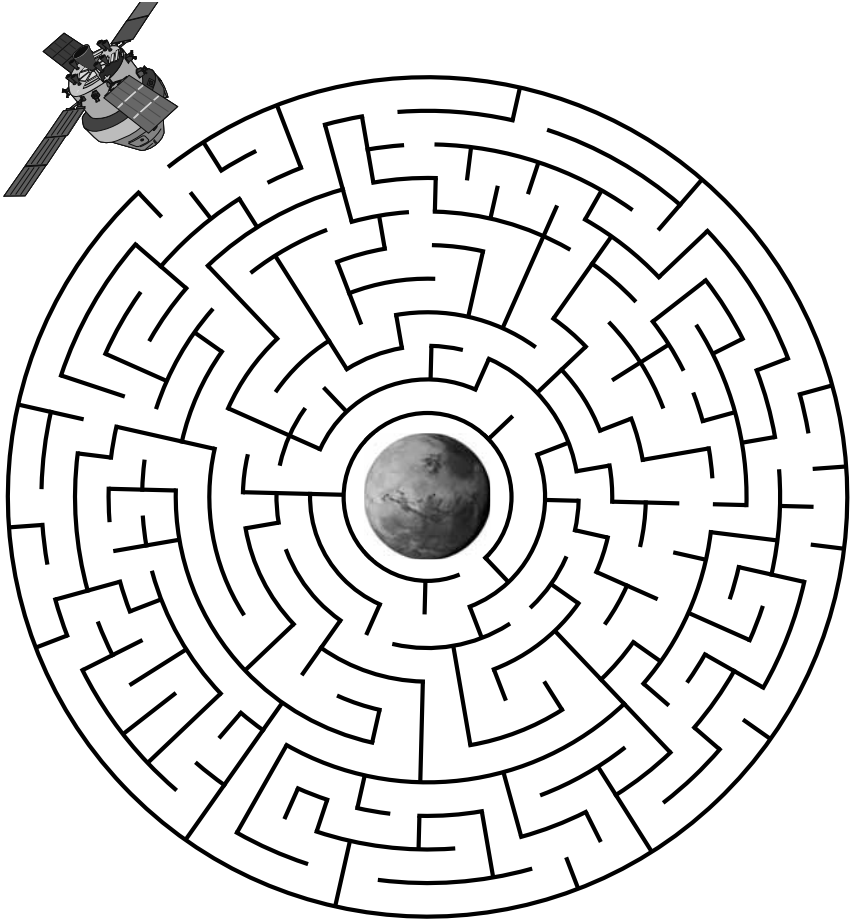

The Orion spacecraft will carry astronauts to the Lunar Gateway, Mars, and other deep space destinations. Orion is designed to keep crew safe during long periods of space travel and will be able to withstand the harsh environment of reentry into the Earth's atmosphere.

# Identical Landers

Circle the two identical Mars Insight landers.

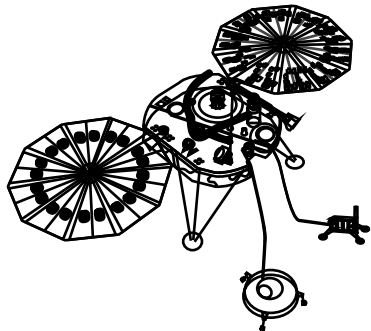
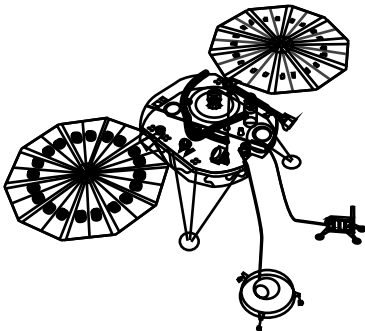
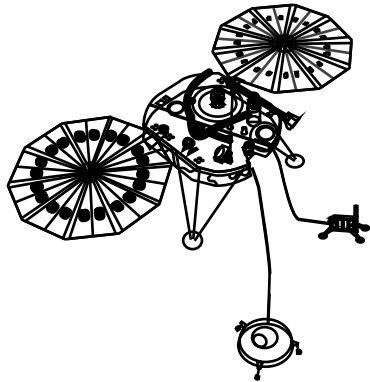
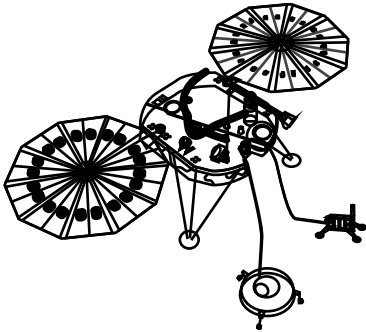
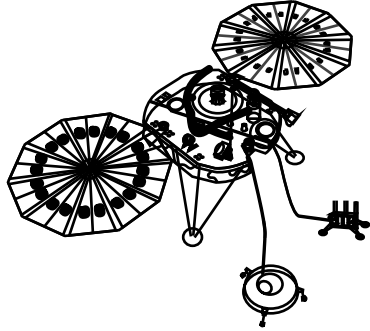
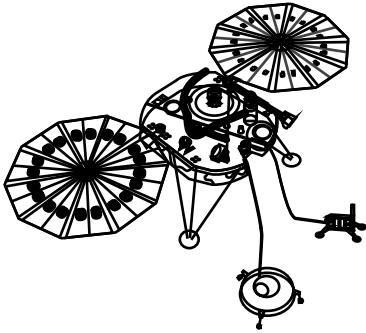

# Sudoku

Fill the empty squares so that each number 1 through 6 appears exactly once in each row, column, and each three-by-two block.

	4		2		
2					5
5				2	1
	3		4		6





# Moon to Mars Word Search

*Circle the words below.*

P T F A R C E C A P S G  
R L U B L N V M R E V A  
O O S A O F S O G Y T T  
P I B I N L Q O R I L E  
U B R O S O L N N A U W  
L O M U T A R N T K F A  
S E U A N I O T E K R Y  
I G N D R V C R S C E B  
O R E I A S O Q W A W K  
N R A T G L T E K C O R  
P H I L P N A M D R P E  
M V Y X I R E X P S Q V  
E A E I P C T J Y Q J O  
C A R G O C Q L T R T R  
N G H S K K K Z I D H K  
M I S S I O N B C Y V S  
L E U H O T O O G H I L  
G T W H R U D S A X J N

ASTRONAUT  
PROPULSION  
GATEWAY  
MARS  
LANDER  
EXPLORE

ROCKET  
MOON  
CARGO  
SLS  
MISSION  
ROVER

POWERFUL  
ORION  
ROBOTIC  
INNOVATIVE  
ENGINE  
SPACECRAFT



# Space Exploration Memory Test

Study the page for 30 seconds. Then turn the page and write down as many objects and words as you can remember.

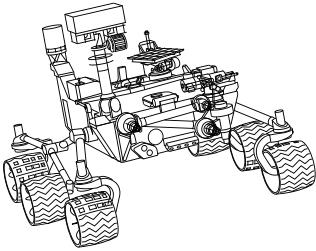

galaxy

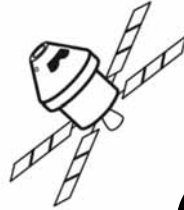

space

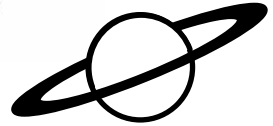

technology

Gateway



Mars

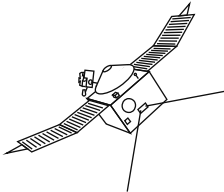

engine

Artemis



# Space Exploration Recall

*Study the previous page for 30 seconds. Write down as many objects and words as you can remember.*

Blank lined writing area for student responses.

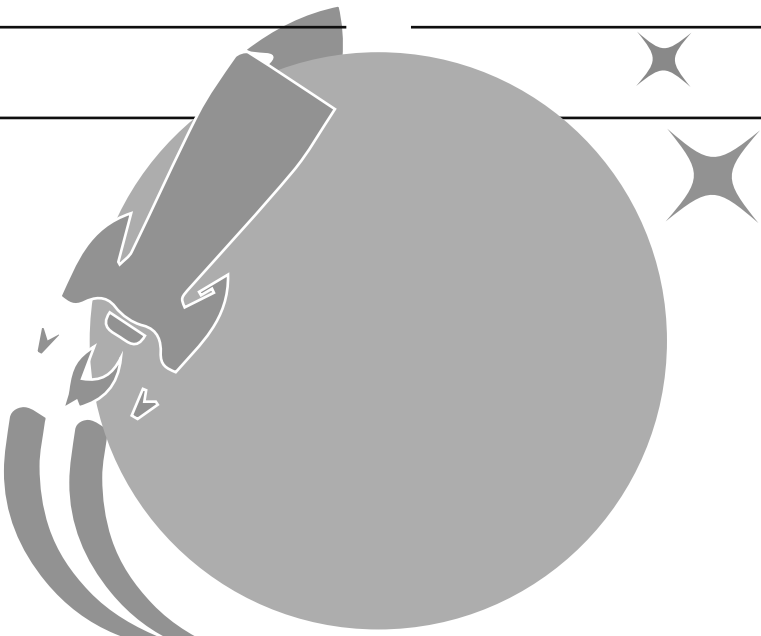

# Sudoku

Fill the empty squares so that each number 1 through 9 appears exactly once in each row, column, and each three-by-three block.

		4		3			7	
				4				9
	6						3	
				6		4	1	
6				7				3
	1	8		5				
	3		9		7		5	
7				1	6			
	2			8		1		

NASA hires people with excellent math skills to achieve its complex and challenging missions.

# Alphabet Path

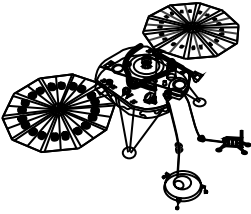

1. In one continuous line, connect the letters of the alphabet from A to Z. If you do not see the next letter of the alphabet in a neighboring circle, add the correct letter to a shaded circle.

B	E	F	P
R	D	●	M
C	B	J	★
A	E	◇	K



2. Match the symbols from the shaded circles to the symbols on the bottom of the opposite page. Then write in the corresponding letters to reveal the name of the NASA lander that arrived on Mars on November 26, 2018.

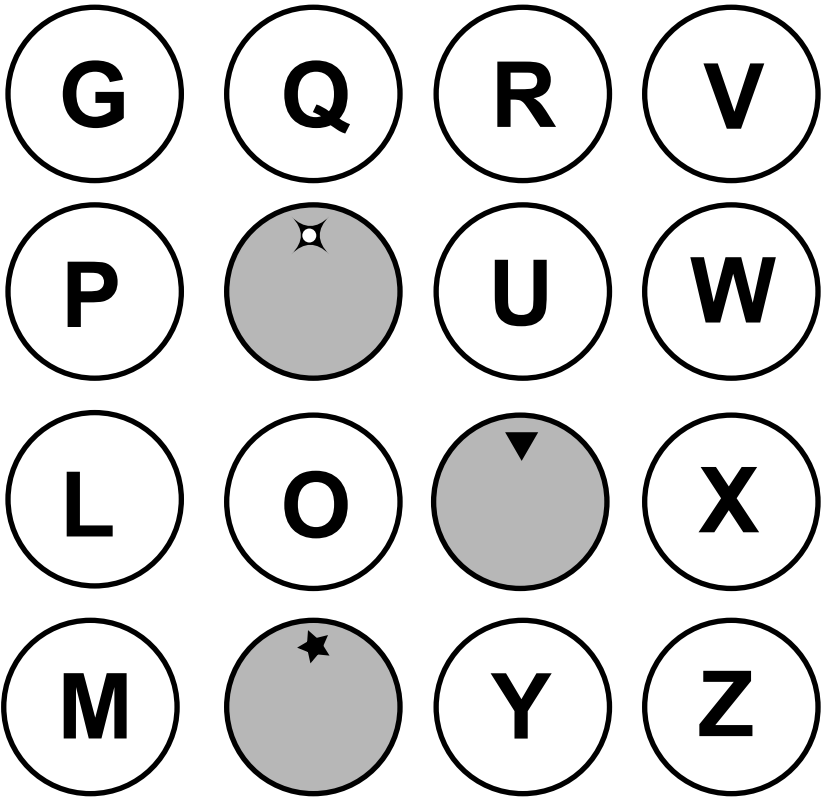

# Satellites, Rovers, and Lander

Match each Mars observer to its shadow.

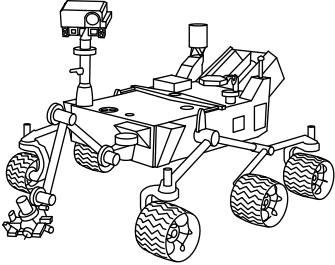

Curiosity

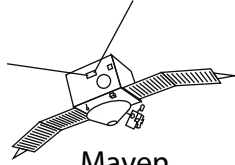

Maven

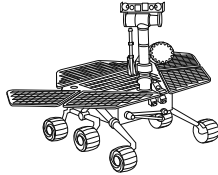
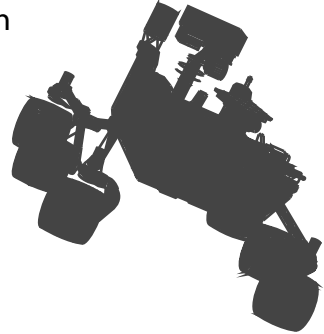

Opportunity

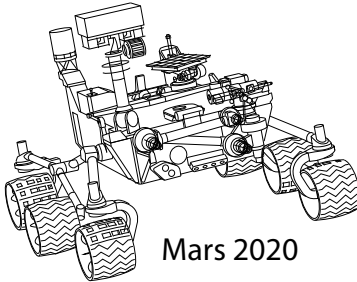
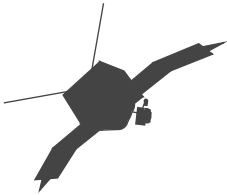

Mars 2020

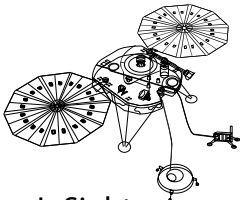
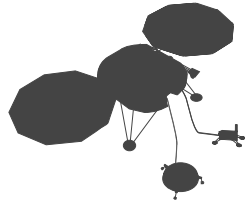

InSight

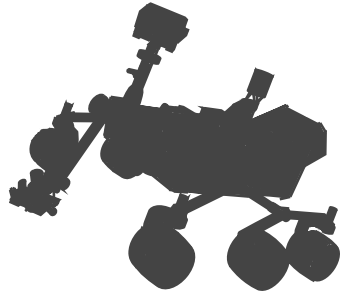

## Two Moons of Mars

Fill in the numbers 1 through 9 so that each equation is correct. Use each number only once.

P	+	I	÷	D	= 8
+		÷		X	
H	+	O	X	E	= 12
—		—		—	
B	÷	S	+	M	= 9
= 2		= 5		= 4	

Match the letter in each box to the code below to reveal the names of the two moons of Mars.

4	7	1	9	1	3



13.8 miles



7.8 miles

2	5	8	6	1	3





# Be a Martian!

Use the code to reveal a message from NASA.

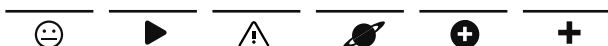
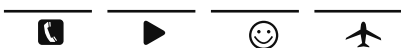

A =	▶	F =	◎	K =	🛡️	P =	⚠️	U =	▭	Z =	▶
B =	⊙	G =	✓	L =	⊘	Q =	□	V =	⊠		
C =	⚙️	H =	☀️	M =	📞	R =	😊	W =	☹️		
D =	+	I =	↑	N =	⚠️	S =	✈️	X =	✳️		
E =	⊕	J =	⊗	O =	⬡	T =	♃	Y =	👁️		

## Mars needs YOU!

Mars will need all kinds of explorers,  
scientists, technologists, engineers,  
mathematicians, artists, designers,  
programmers, and teachers--

but most of all, Mars will need YOU!

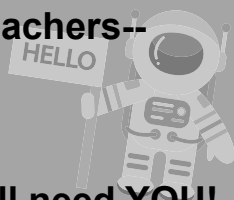

# Life on Mars

Find and mark 12 differences in the two pictures.

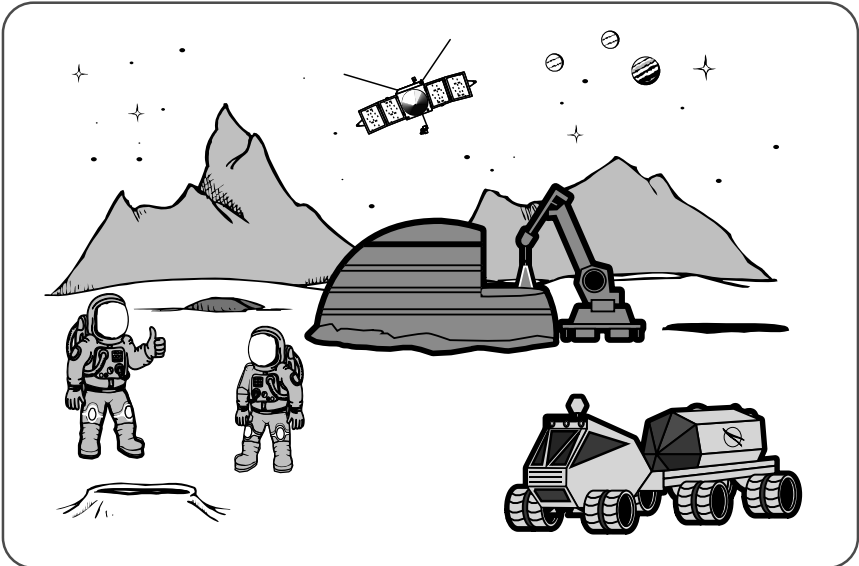
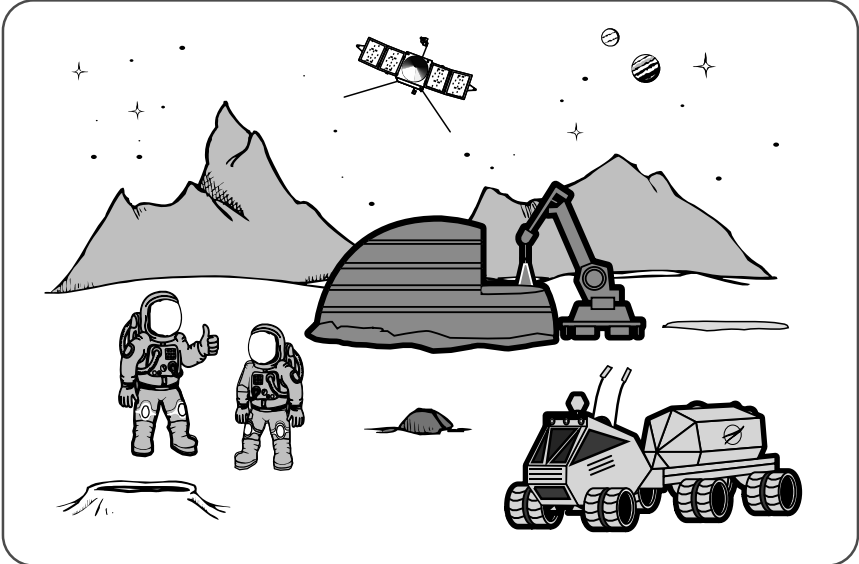

# Land on Mars

*Help the Mars 2020 rover safely land on Mars.*

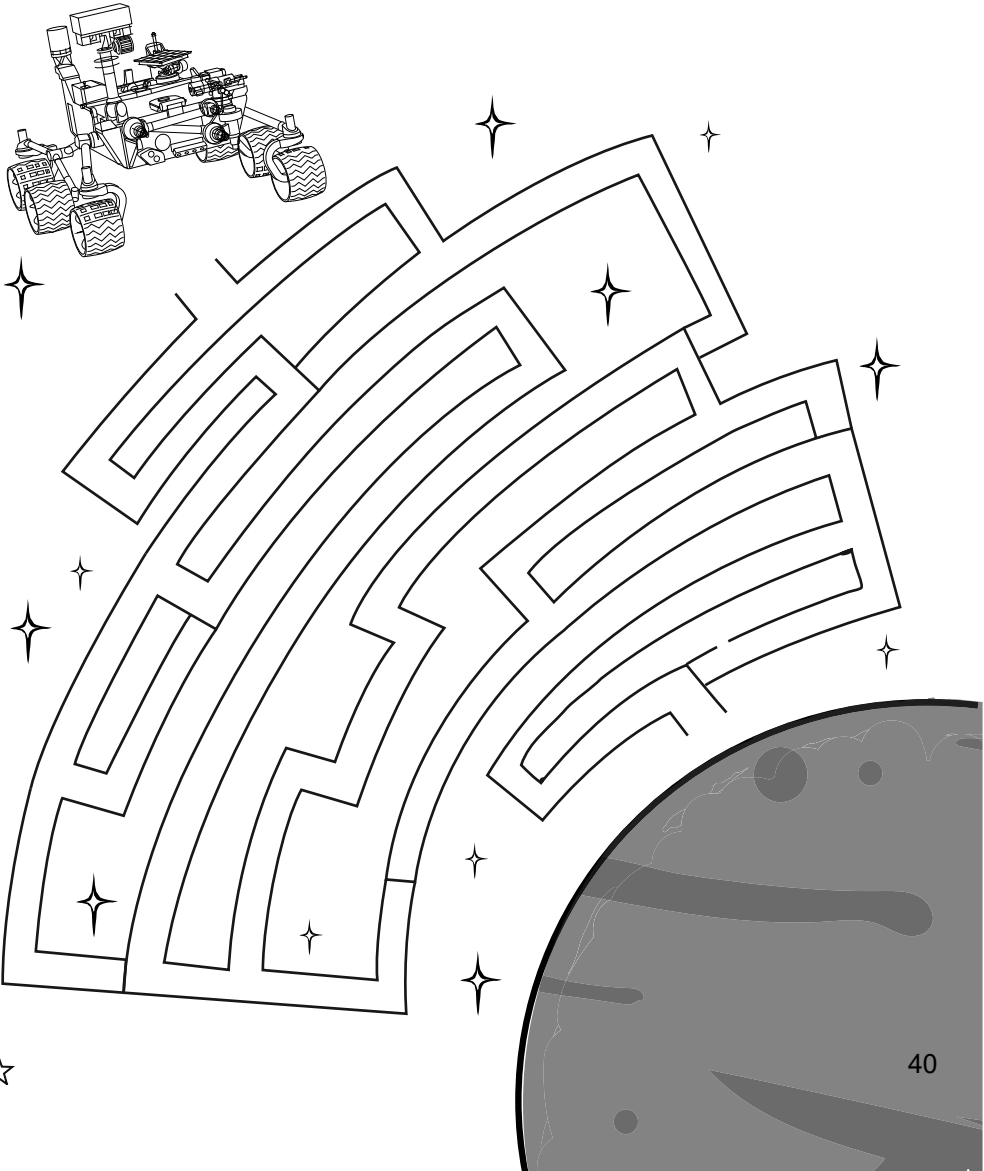

# Complete the Pattern

Complete shading the boxes below by continuing the patterns that have been started for you.

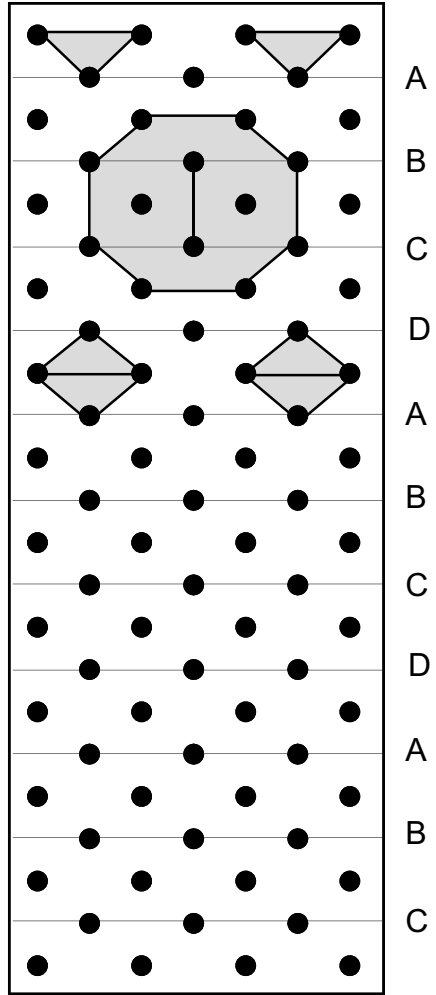
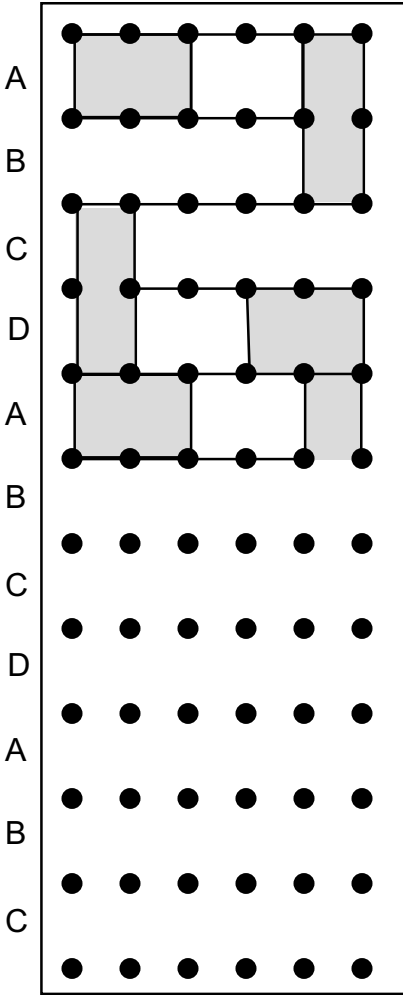

Scientists and engineers look for patterns to make sense of observations.



# What Do You Think?

Circle your response for each question. **Objects are not to scale.**



**Which is taller?**

Space Launch System  
OR  
Statue of Liberty

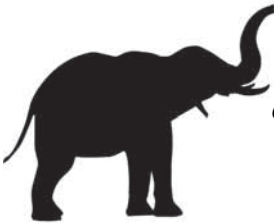

**How many elephants?**

About how many elephants  
could fit in the cargo area of the  
first SLS Crew rocket?

1-2    10-12    100-120



**Which is taller?**

Hyperion, the worlds tallest  
known Redwood tree  
OR  
the first SLS Cargo rocket



# Small Steps to Giant Leaps

*Unscramble the tiles to reveal a message.*

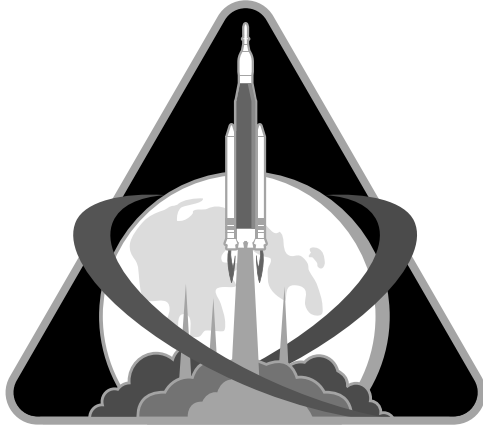

e p s .	G i a	p s	o f
a	s t	b u	n t
i e s	s e r	i l t	a l l
a r e	o n	l e a	s m

## Create Your Own Stanza

*Finish "Moving Forward to the Moon" on the opposite page by adding seven more lines. Have the second, fourth, and sixth lines end in rhyming words. Be sure to include humans traveling to Mars since that is the next giant leap.*

1. \_\_\_\_\_

2. \_\_\_\_\_

3. \_\_\_\_\_

4. \_\_\_\_\_

5. \_\_\_\_\_

6. \_\_\_\_\_

7. \_\_\_\_\_





## *Moving Forward to the Moon*

We're moving forward to the Moon  
To build a colony  
Fifty years of exploration  
And more we'd like to see  
We will unite the world through space  
To stretch our boundaries  
As we all move forward to explore the Moon.

We'd like to show the world the Moon  
In ways they've never seen  
And declare our honor to the LEM  
Based at Tranquility  
We'd like to probe the universe  
In ways that will be key  
As we all move forward to explore the Moon.

We'd like to use all our STEM  
To search the galaxy  
Exploring both time and space -  
Seek new realities  
We'd like to fill the cosmos with  
Peace and humanity  
As we all move forward to explore the Moon.

We're building a new Gateway  
It is our destiny  
A new frontier that we'll explore  
Like Eagle in history  
That one small step for man still stands  
A new giant leap is in the plans  
As we all move forward to explore the Moon

- Rebecca Strong

EXPLORE  
MOON to MARS





# ... and on to Mars!



**STEM Engagement:**

[nasa.gov/stem](https://nasa.gov/stem)

**Apollo Program:**

[nasa.gov/apollo50th](https://nasa.gov/apollo50th)

**Explore Moon to Mars:**

[nasa.gov/moon2mars](https://nasa.gov/moon2mars)

**Short Rocket Science Videos:**

[nasa.gov/exploration/systems/sls/no-small-steps-videos](https://nasa.gov/exploration/systems/sls/no-small-steps-videos)

**Forward to the Moon Explorer**

**Activities and Answer Key:**

[nasa.gov/exploreractivities](https://nasa.gov/exploreractivities)

[nasa.gov](https://nasa.gov)

NP-2019-06-2726-HQ