

Space Technology Mission Directorate

Small Spacecraft Technology

MARKETS & MOTIVATIONS

Andrew Petro

Briefing to the NASA Advisory Committee

July 28, 2014

OUTLINE

- ✧ Small Satellite Launch Market Projections
- ✧ NASA Small Spacecraft Technology Program
Development and Demonstration
- ✧ Examples of Other NASA Activities in Small Spacecraft
Science
Human Exploration and Operations
- ✧ Examples of ESA Small Spacecraft Technology
Development and Demonstration
- ✧ Questions and Discussion

“Small Satellites Market Pull”

- NASA State of the Art Report
- SMD-STMD study of how small spacecraft can address Decadal Survey mission needs – starting in Aug-Sept 2014
- Informal assessments of market pull
 - Annual Government Cubesat Forum – (NASA, USAF, NRO, NRL, DARPA, ORS, etc.)
 - Smallsat and Cubesat conferences
- Identified civil and commercial markets:
 - Earth remote sensing
 - Space weather and heliophysics
 - Communications
 - NEA exploration (i.e., ARM secondary payloads)
 - In-space subscale testing of technology
 - Education and public outreach
- Launch demand market studies (rideshare, ISS deploy, small launchers)

“Small Satellites Market Pull”



Small can also mean: Affordable, Rapid, Transformative

Market studies of disruptive technologies

Role of STMD versus SMD & HEOMD in push versus pull technology development

REFERENCE:

2014 Nano/Microsatellite Market Assessment

Developed by:

Ms. Elizabeth Buchen

Mr. Dominic DePasquale

Published by:

SpaceWorks Enterprises, Inc. Atlanta, GA

Historical Nano/Microsatellites Launched: 2000 - 2013 (1 - 50 kg)

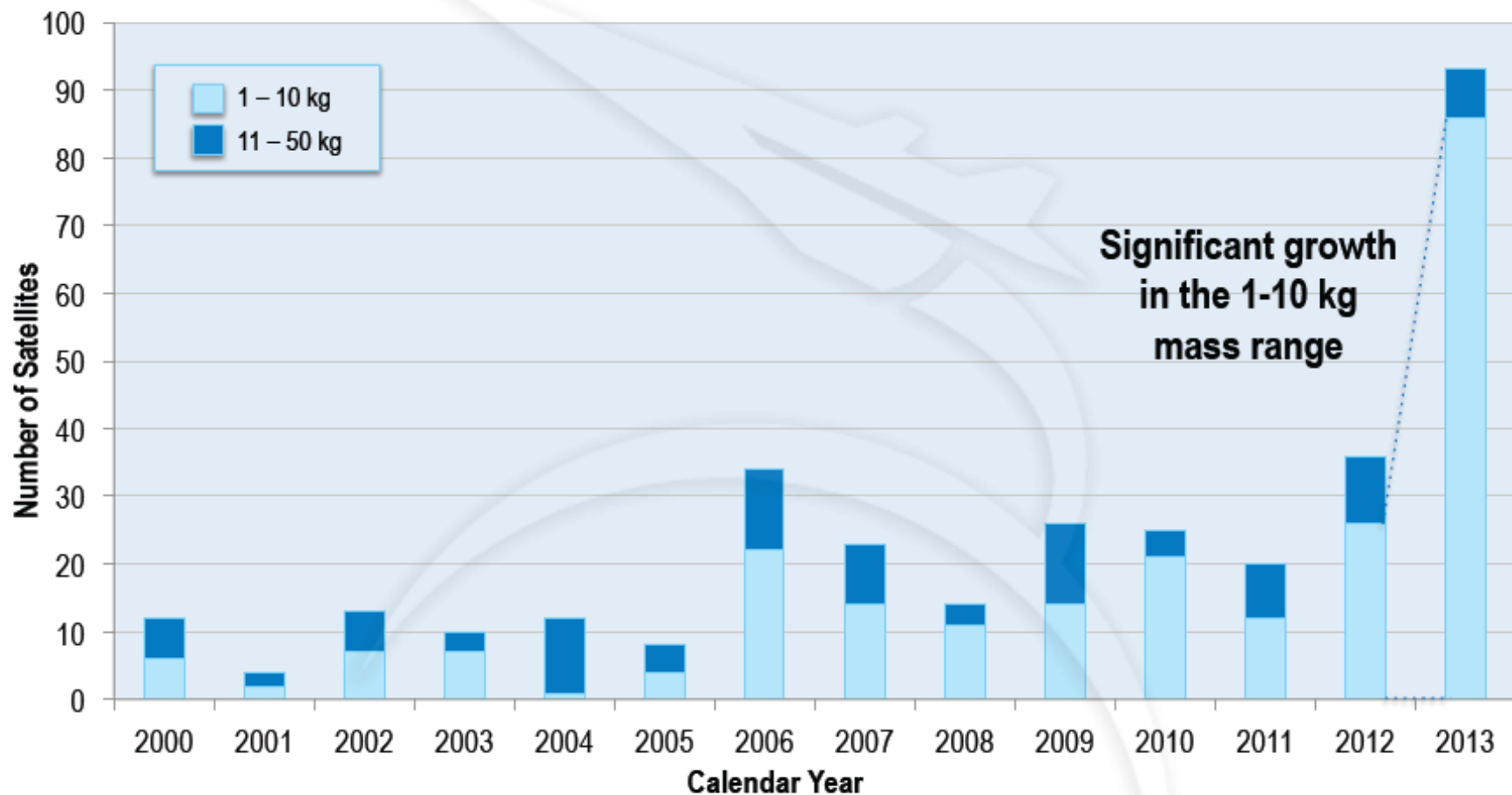

A 330% increase in attempted nanosatellite (1-10 kg) deliveries in 2013, compared to 2012, shows signs of an emerging and growing launch market

* Please see End Notes 1 and 2.

Nano/Microsatellite Launch History and Projection (1 - 50 kg)

Projections based on announced and future plans of developers and programs indicate between 2,000 and 2,750 nano/microsatellites will require a launch from 2014 through 2020

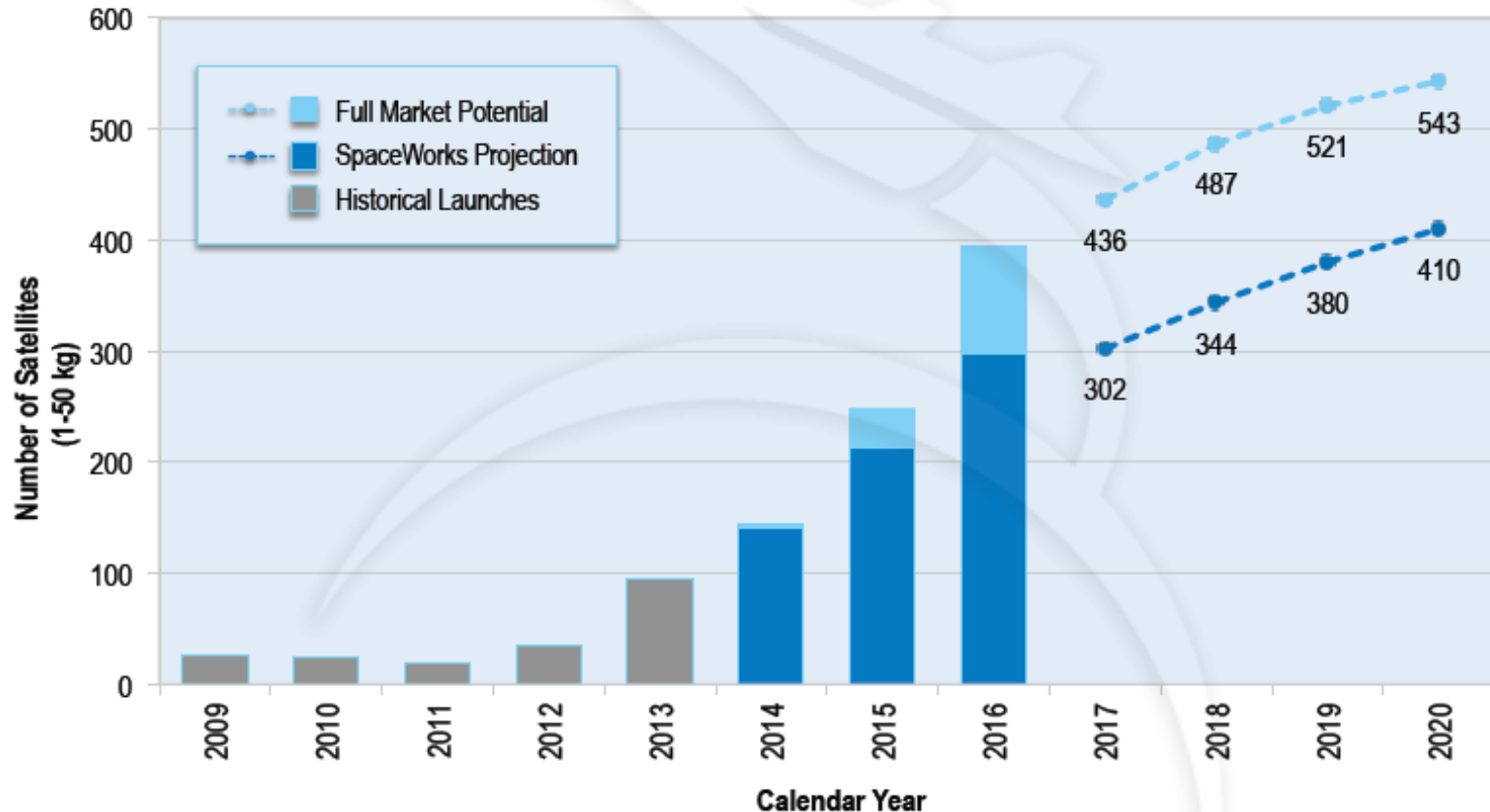

The Full Market Potential dataset is a combination of publically announced launch intentions, market research, and qualitative/quantitative assessments to account for future activities and programs. The SpaceWorks Projection dataset reflects SpaceWorks' expert value judgment on the likely market outcome.

* Please see End Notes 1, 2, 4, 5, and 6.

Nano/Microsatellite Trends by Purpose (1 - 50 kg)

Over half of future nano/microsatellites will be used for Earth observation and remote sensing purposes (compared to 12% from 2009 to 2013)

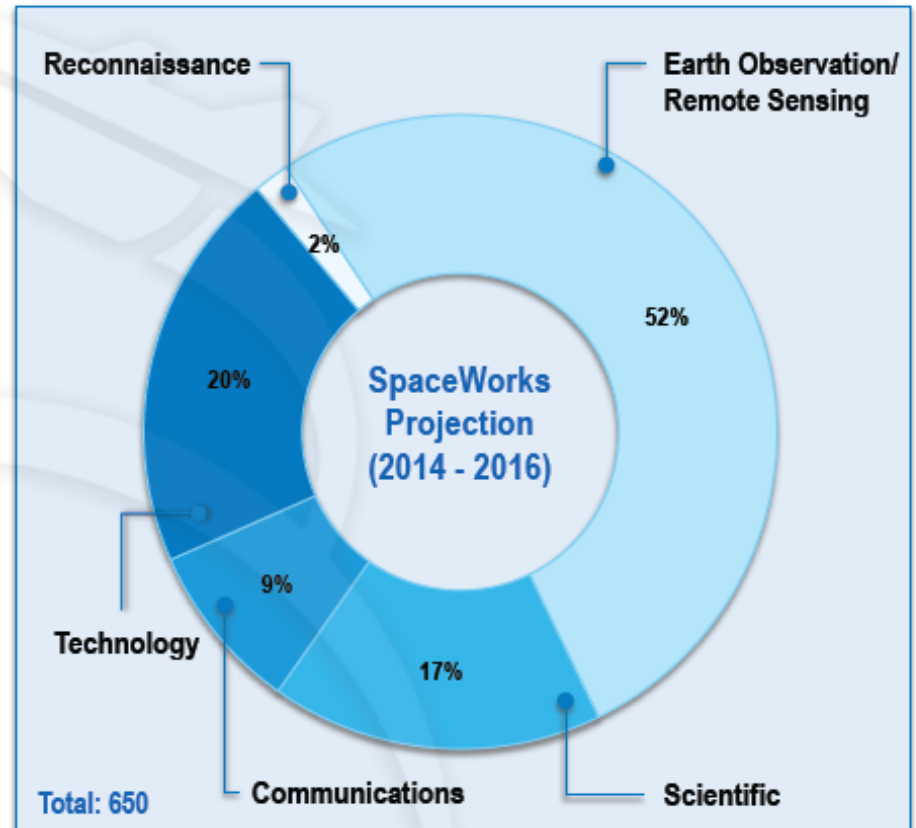
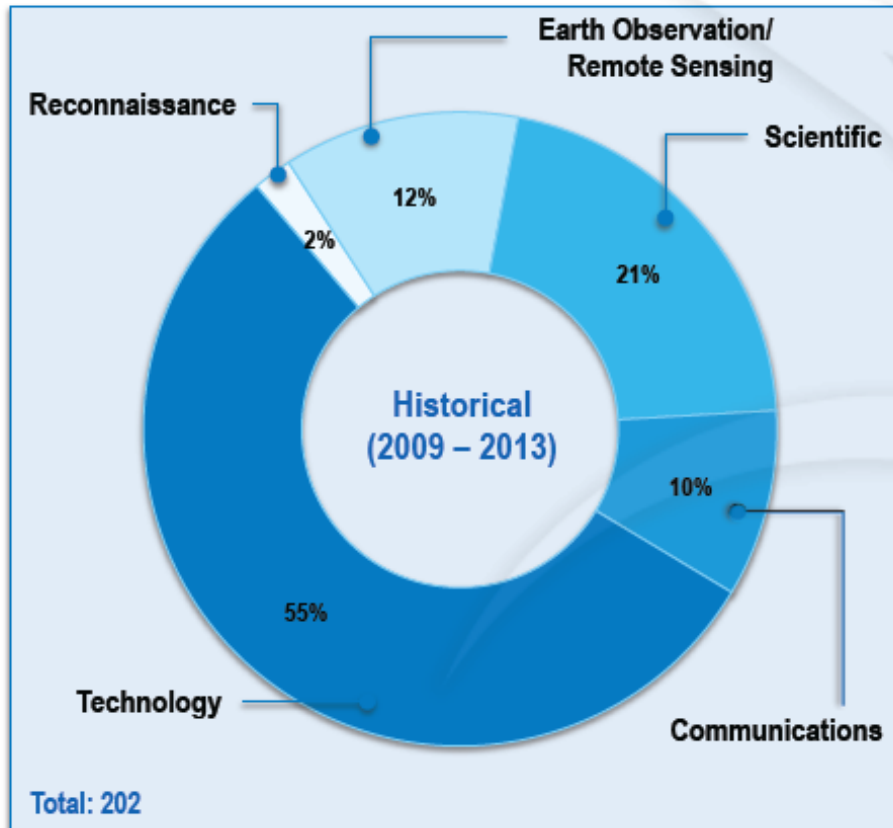

A smaller proportion of technology development/demonstration nano/microsatellites will be built in the next few years (20% vs. 55% from 2009 to 2013)

* Please see End Notes 2, 6, and 7.



Small Spacecraft Technology Program

Small Spacecraft Technology Program

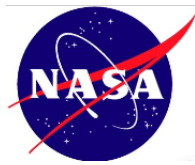

Affordable, Rapid, & Transformative Development and Demonstration

Objectives:

- To develop and demonstrate new small spacecraft technologies and capabilities for NASA's missions in science, exploration and space operations
- To promote the small spacecraft approach as a paradigm shift for NASA and the larger space community.

Focused Technology Development Projects in:

Communications, Avionics, Propulsion, Power, Instruments, Manufacturing, Small Earth Return Vehicle

Flight Demonstration Projects in:

Radio and Laser Communications
Formation Flight and Docking
Low cost satellite buses
Smallsat swarms for space science missions

Implemented through:

Directed NASA projects
Contracts with private industry
University-NASA partnerships
Collaboration with SBIR and other programs

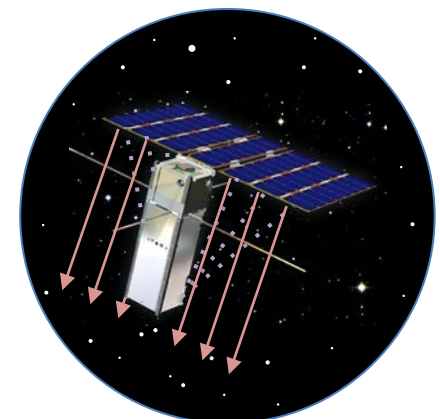
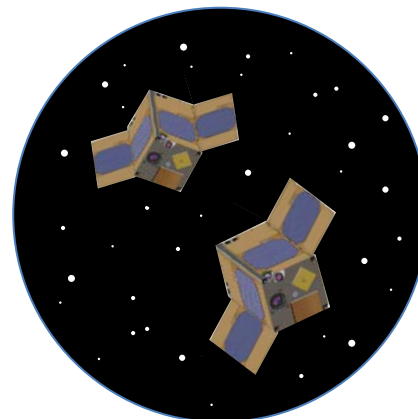
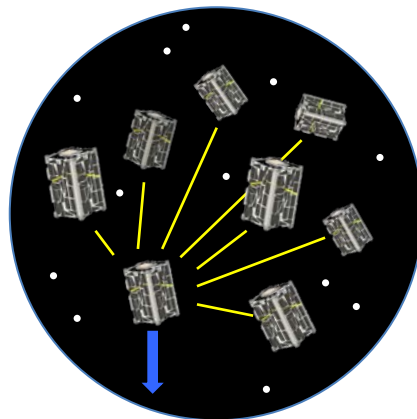
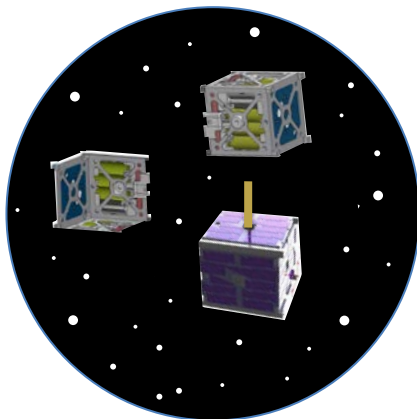



Small Spacecraft Technology Program

Nationwide Participants and Partners

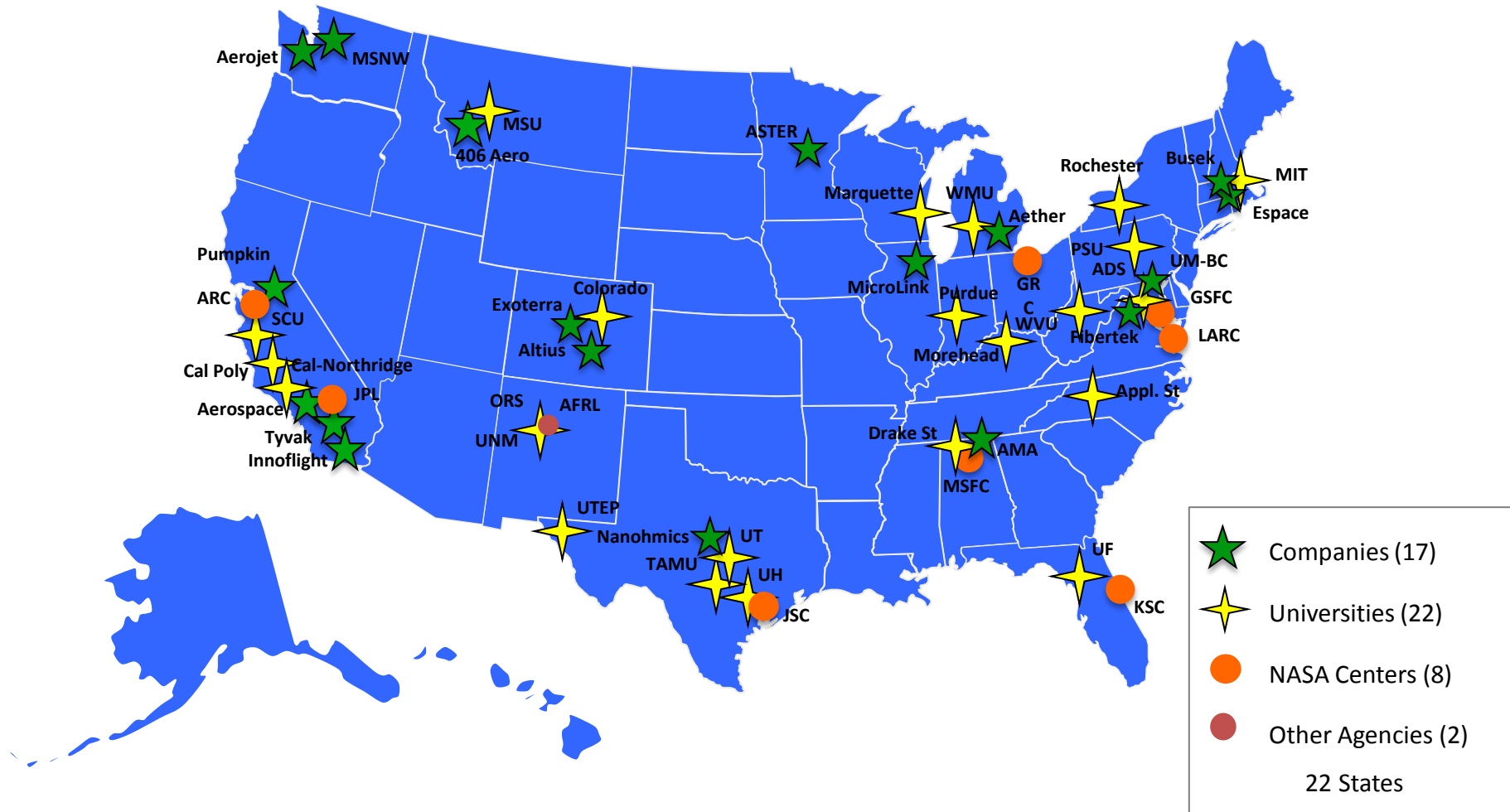

Small Spacecraft Technology Program

Projects: 2013-2015

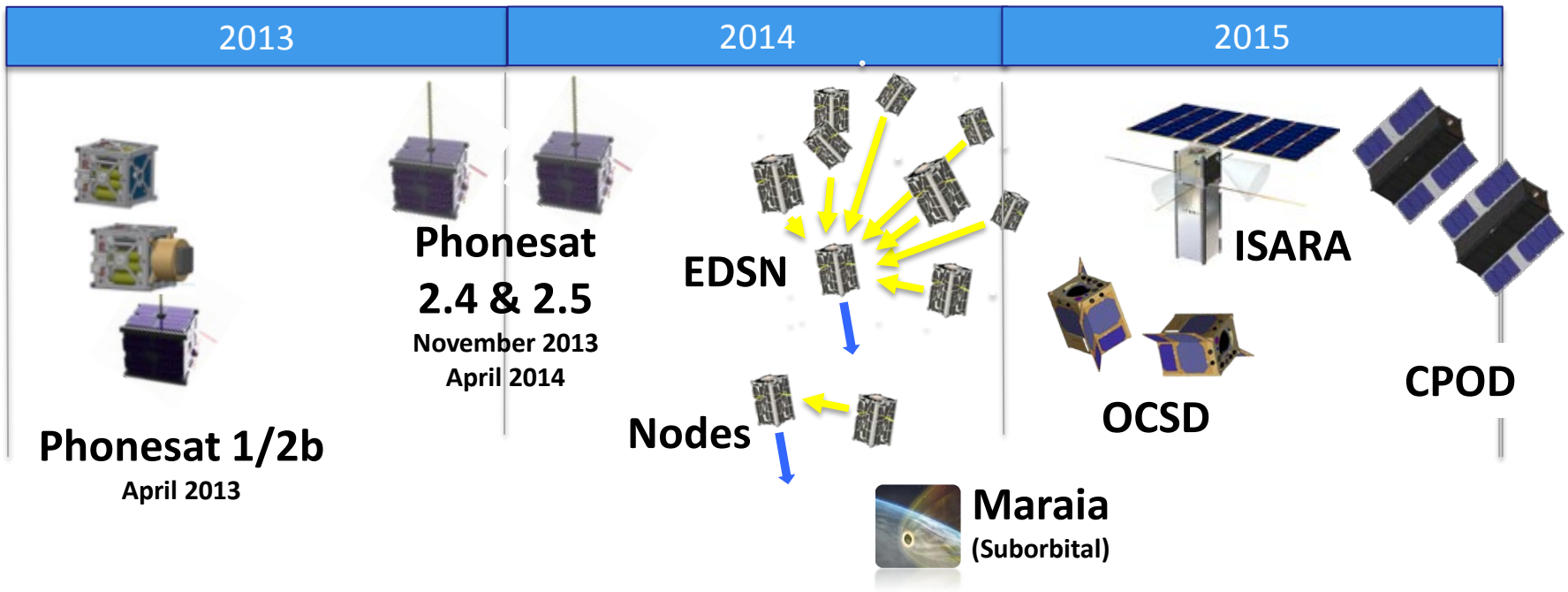

Smallsat Technology Partnerships
13 projects with NASA-University collaboration

5 Propulsion Technology Projects

SBIR - Deep Space Cubesats

EDSN: Edison Demonstration of Smallsat Networks
ISARA: Integrated Solar Array and Reflectarray Antenna
OCSD: Optical Communications and Sensor Demonstration
CPOD: Cubesat Proximity Operations Demonstration

Small Spacecraft Technology "Pathways"

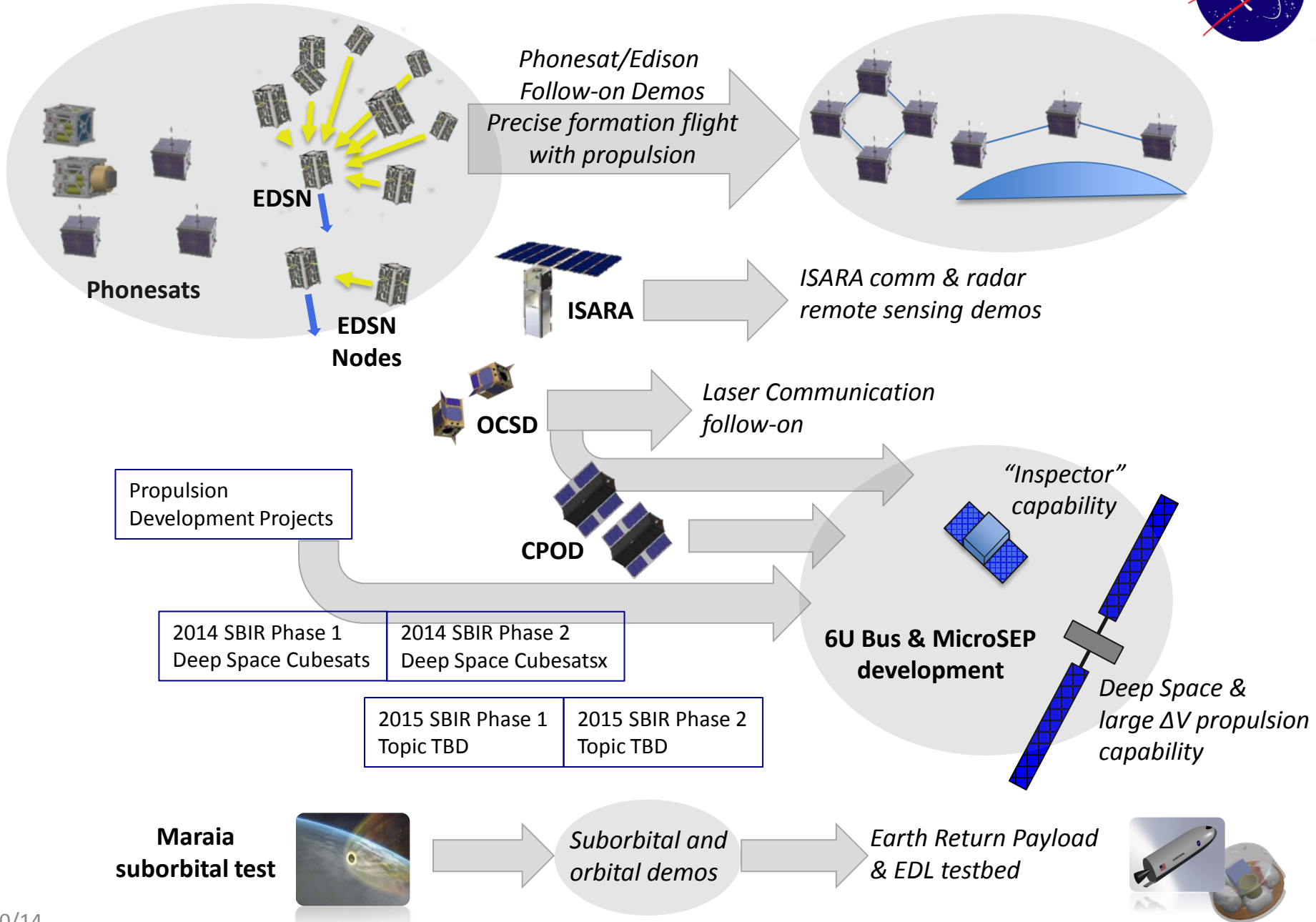

STMD Involvement in Small Spacecraft

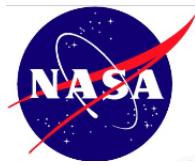

Small Spacecraft Technology

- Focused technology development
- Flight demonstration projects

Game Changing Development

- General cross-cutting technology development
- Miniaturized Electro spray Propulsion development projects

SBIR/STTR

- Existing subtopics for small spacecraft technology
- 2014 Select topic: Deep Space Cubesat Technology

Flight Opportunities

- Technology payload development and test opportunities (FY13 NRA, etc.) – Suborbital
- Potential orbital flight opportunities

Centennial Challenges

- Prize competitions in formulation

Technology Demonstration Missions

- ESPA-class spacecraft flight demonstrations

NIAC

Space Technology Research Grants
Center Innovation Fund



General cross-cutting concept & technology development
and some small spacecraft projects



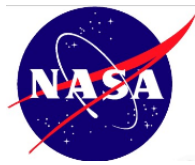

STMD also supports the **Cubesat Launch Initiative** in HEOMD and the **HOPE** Program with SMD and OCE

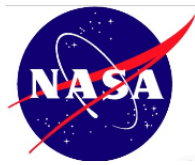

Science

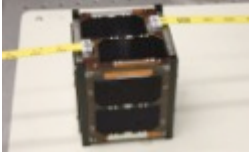
Earth Science Smallsat Activities

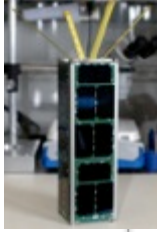

2013	2014	2015	2016
 <p data-bbox="181 636 349 668">M-Cubed2</p>	 <p data-bbox="542 644 616 672">IPEX</p>	 <p data-bbox="919 639 1035 711">GRIFEX (notional)</p>	
<p data-bbox="112 739 343 861">M-Cubed2 (Michigan Multipurpose MiniSatellite)</p> <p data-bbox="112 896 417 989">Validation of on-board new radiation-hard-by-design FPGA</p> <p data-bbox="112 1025 405 1082">Led by Jet Propulsion Lab</p> <p data-bbox="112 1118 328 1146">Task Cost: \$1M</p> <p data-bbox="112 1182 401 1239">Launch: Fall 2013 on NRO-L39</p>	<p data-bbox="452 729 755 822">IPEX (Intelligent Payload Flight Experiment)</p> <p data-bbox="432 858 755 1103">Validation of high data rate cameras (Gbps), and autonomy algorithms to deliver high value, low-latency products with >20x reduction in instrument raw data rate</p> <p data-bbox="432 1139 726 1196">Led by Jet Propulsion Lab</p> <p data-bbox="432 1232 649 1260">Task Cost: \$1M</p> <p data-bbox="432 1296 722 1353">Launch: Fall 2013 on NRO-L39</p>	<p data-bbox="838 743 1141 836">GRIFEX (GEOCAPE ROIC In-Flight Experiment)</p> <p data-bbox="838 872 1141 1025">Verify performance of fast imaging detector readout Integrated Circuit (ROIC) with in-pixel A-D converter</p> <p data-bbox="838 1061 1132 1118">Led by Jet Propulsion Lab</p> <p data-bbox="838 1153 1078 1182">Task Cost: \$1.9M</p> <p data-bbox="838 1218 1089 1246">Launch: NET 2014</p>	<p data-bbox="1528 772 1760 801">CYGNSS (EV-2)</p> <p data-bbox="1460 836 1818 893">Cyclone Global Navigation Satellite System</p> <p data-bbox="1460 929 1818 1022">8 LEO nanosats using GPS reflections to monitor ocean surface roughness</p> <p data-bbox="1460 1058 1731 1115">Led by University of Michigan</p> <p data-bbox="1460 1150 1789 1179">Lifecycle Cost: \$151.7M</p> <p data-bbox="1460 1215 1769 1243">Launch: Early CY 2016</p>

InVEST: In-Space Technology Validation for Earth Science

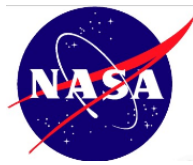

The InVEST solicitation sought small instruments and instrument subsystems that will advance technology to enable relevant Earth science measurements and targeted the cubesat platform. The first four awards were selected in April 2013.

The ***Microwave Radiometer Technology Acceleration (MiRaTA)*** cubesat will validate multiple subsystem technologies and demonstrate new sensing modalities that could dramatically enhance the capabilities of future weather and climate sensing architectures - MIT Lincoln Laboratory

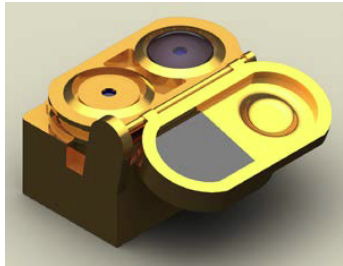
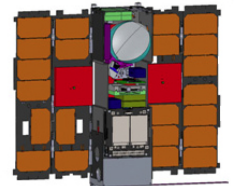

The ***Radiometer Assessment Using Vertically Aligned Nanotubes (RAVAN)*** project will demonstrate a bolometer radiometer that is compact, low cost, and absolutely accurate to NIST traceable standards. RAVAN could lead to affordable cubesat constellations that, in sufficient numbers, might measure Earth's radiative diurnal cycle and absolute energy imbalance to climate accuracies (globally at 0.3 W/m^2) for the first time. - Johns Hopkins Applied Physics Laboratory

The objective of the ***Cubesat Flight Demonstration of a Photon Counting Infrared Detector (LMPC)*** is to demonstrate in space, a new detector with high quantum efficiency and single photon level response at several important remote sensing wavelength detection bands from 0.9 to 4.0 microns. - The Aerospace Corporation

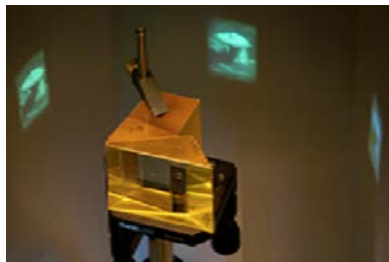
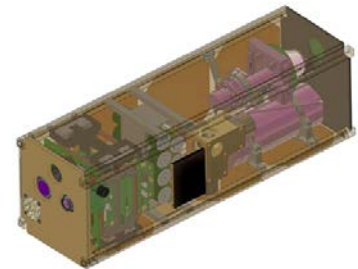

The ***HyperAngular Rainbow Polarimeter (HARP)*** will validate a technology required by the Aerosol-Cloud-Ecosystem (ACE) mission concept and prove the capabilities of a highly-accurate, wide-FOV, hyperangle, imaging polarimeter for characterizing aerosol and cloud properties. - University of Maryland, Baltimore County

Earth Science Flight Program Opportunities



Earth Venture - 2 (EV-M): Complete, self-contained, small missions

- Small sat or stand alone payload for Mission of Opportunity
- \$150 M total development cost
- Solicited in FY11 and every 4 years
- Class D (5y development)
- EV-2 was first Venture full spacecraft mission call
 - AO released June 17, 2011
 - **Cyclone Global Navigation Satellite System (CYGNSS)** selected July 2012
 - 8 microsats (18 kg ea.) for GPS reflectometry to measure ocean surface winds
 - LEO; 35° inclination, 500 km altitude
 - NASA provided launch vehicle; sized for a Pegasus

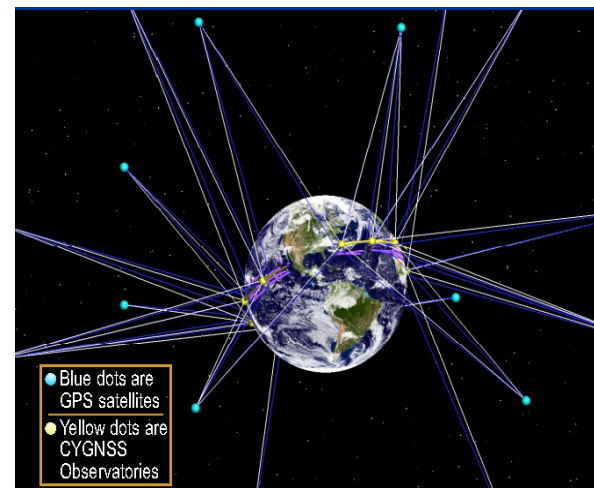
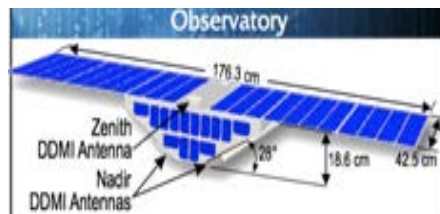
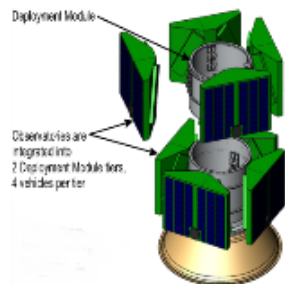

EV Schedule	Type	Solicitation	Selection	Launch/Delivery
EV-2	Full Orbital	2011	2012	LRD ~2016
EV-4	Full Orbital	2015	2016	LRD ~2021

Heliophysics Involvement in Small Spacecraft

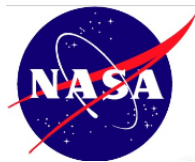

ROSES Solicitations

- An open solicitation to propose cubesats for Heliophysics research has been included in our ROSES NRAs
 - ROSES-12: LCAS solicitation: **CeREs** selected

CeREs: A Compact Radiation bElT Explorer to study charged Particle dynamics in Geospace.

- Lead: NASA Goddard Space Flight Center
 - Partner Organization: Southwest Research Institute
 - Science: Study charged particle dynamics; Radiation Belt losses
 - Implementation: A 3- year low earth orbiting cubesat, carrying a Compact High Resolution Electron Ion Telescope (CoHeREnT)
-
- **Instrument Development**
 - Annual ROSES solicitations
 - Instrument development supporting Heliophysics science (not restricted to small spacecraft)
 - Proposals solicited annually
 - Approximately 1-4 awards per year
 - Several selected for development of compact instrumentation

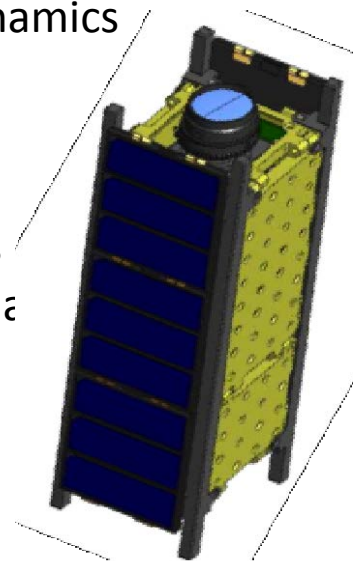

Previous Heliophysics Small Spacecraft Missions

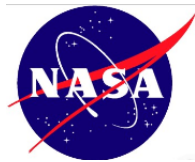

- **THEMIS: Time History of Events and Macroscale Interactions during Substorms**
 - Science Goal: to determine what physical process in near-Earth space initiates the violent eruptions of the aurora that occur during substorms in Earth's magnetosphere.
 - Midex Explorer Mission: Selected March 2003; Launched February 17, 2007
 - Constellation of 5 identical spacecraft
 - 126 kg each (with propulsion)
 - Completed Prime mission; three THEMIS probes operating as an extended mission; two of the 5 s/c repurposed into lunar orbit are operating as the ARTEMIS mission; **A**cceleration, **R**econnection, **T**urbulence and **E**lectrodynamics of the **M**oon's Interaction with the **S**un"
- **Space Technology 5 (ST5)**
 - New Millennium Program
 - Technology demonstrations and research on the Earth's magnetosphere
 - Constellation of 3 identical spacecraft
 - 25 kg each (with propulsion)
 - Launched March 22, 2006, completed June 20, 2006

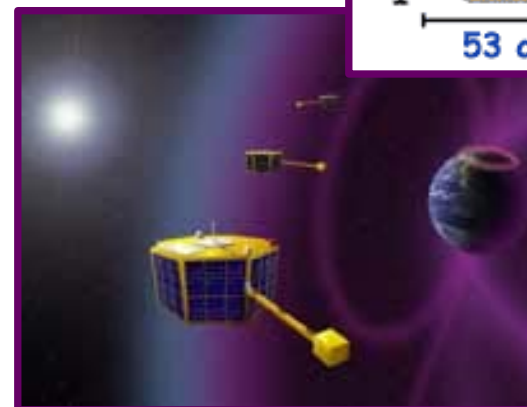
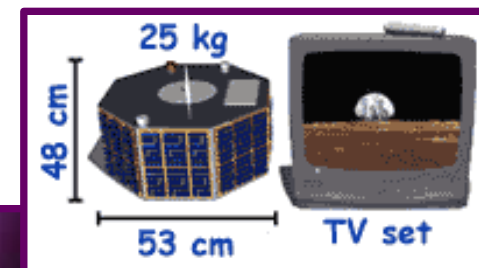
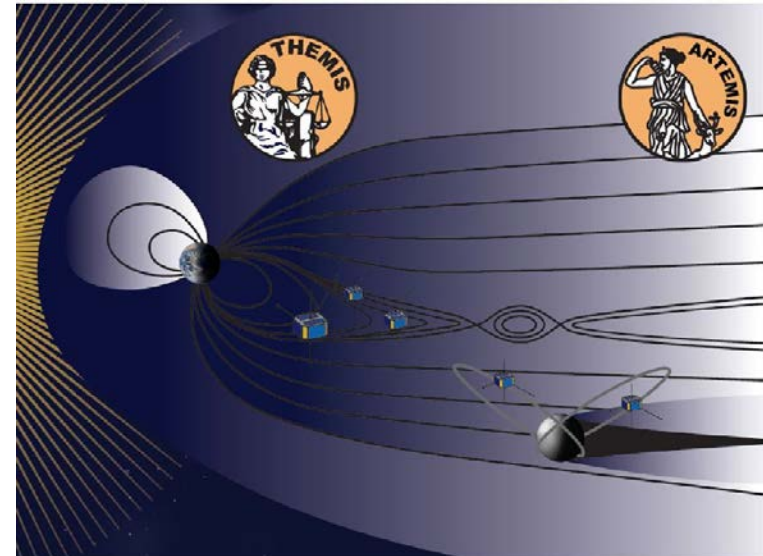

Planetary Science Involvement in Small Spacecraft



SMD Astrobiology Small Payloads Program

O/OREOS Nanosat

Organism/Organic Exposure to Orbital Stresses

Goal: Astrobiology -- viability of microorganisms and astrobiologically relevant organics over 6-month space exposure.

Technology:

- 10x10x30 cm Nanosat Bus (3U)
- UV-Vis Spectrometer (1 cube)
- Biology growth-&-analysis system (1 cube)

Success: Launched Nov. 19, 2010. Full mission success, both payloads, May 23, 2011. Funding, concept to orbital data analysis: \$2.5 million. 4 refereed papers published, 3 in preparation.

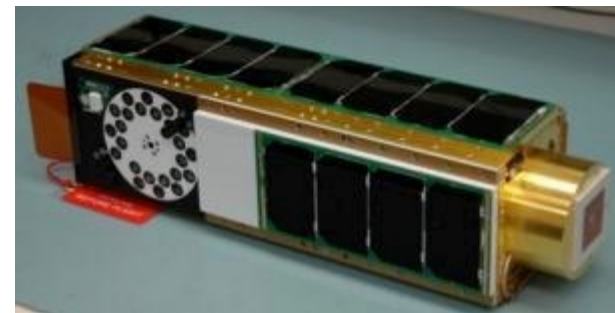
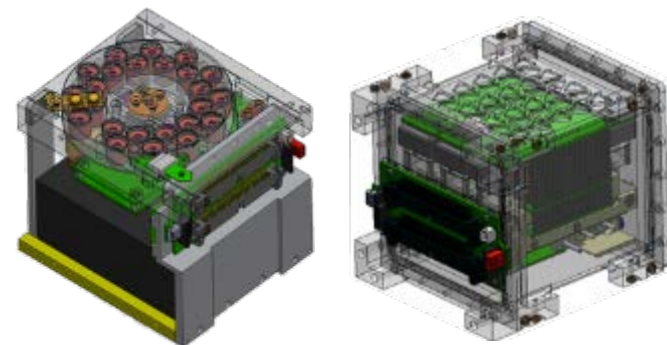
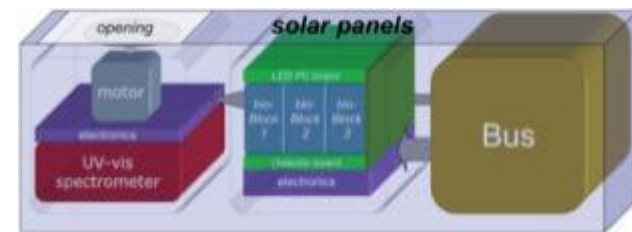

Planetary Science Involvement in Small Spacecraft



INSPIRE: Interplanetary NanoSpacecraft Pathfinder In a Relevant Environment

PI: Andrew Klesh, PM: Lauren Halatek, Jet Propulsion Laboratory

Objectives:

- **Demonstrate key nano-spacecraft abilities:** telecommunications, navigation, command & data handling, relay communications, and deep-space reliability/ fault protection
- **Demonstrate science utility** with compact payloads (Vector Helium Magnetometer & imager)
- **Demonstrate new technologies** for low-cost COTS / university components

Overview:

- **Volume:** 3U (10x10x30cm)
- **Mass:** 4.8 kg
- **Power Generation:** 20 W
- **Data Rate:** 62-64000 bps
- **ACS:** Cold gas (3D printed), 0.02 deg knowledge, 1-2 deg control
- **Radio:** DSN Compat X-band/2-way Nav, UHF xlink
- **Payloads:** Magnetometer, Agile Sci Algorithm, cam

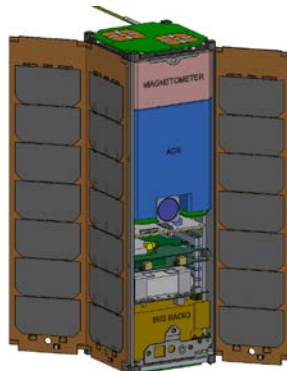

Enabling high value science:



Low-Cost Heliophysics:
Constellation for solar wind mapping



Supplemental Science:
Going into high-risk areas

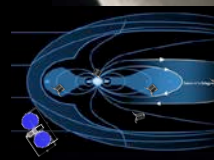

Novel Science:
Distributed sensing



Status:

- **Selected** for launch by NASA's Cubesat Launch Initiative (2/26) – awaiting manifest
- **Schedule:** Ready for launch Fall 2014
- **Mission Duration:** 1-3 months, 1 kbps at max distance 1.5x10E6 km (DSN 34m dish)

Planetary Science Involvement in Small Spacecraft

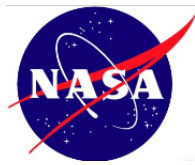

In Development

RASIR: Reactivity Analyzer for Soil, Ices, & Regolith

A 1U Optical Sensor Array to Measure Extraterrestrial Soil Chemistry

Primary Science Objectives

- Measure chemical processes that alter or remove **organics** from the environment of interest:
- Correlate **organic inventory** measured by other payload instruments to **soil reactivity** levels

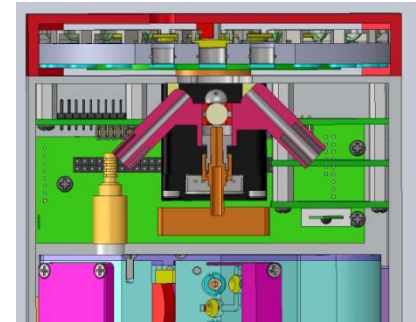

Scientific Lineage: MOx, MOI, MAOS, SEVO

Flight Heritage: O/OREOS SEVO

Technical Approach: *Time sequence of UV-Vis or fluorescence spectra of **sensing films** in bottom of each sample well*

200 – 1000 nm, 1 – 2 nm resolution

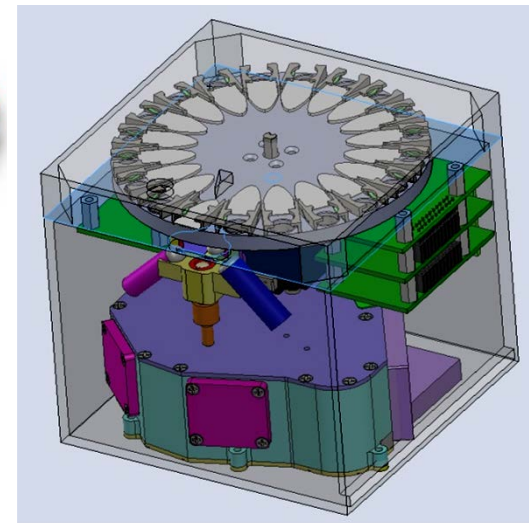
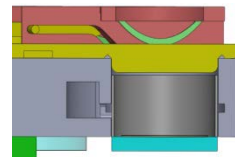
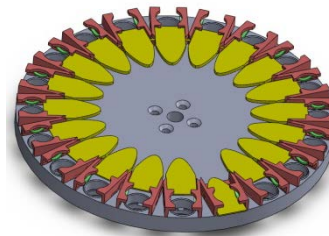



Small Instruments for Planetary Science

ROSES Solicitations

Opportunities for the community to propose small instruments for Planetary research can be found in our Research Opportunities in Space and Earth Science (ROSES) NRAs. Science payloads on most future planetary science spacecraft will be limited to small, low-mass, and low power, consumption instruments. Some of these instruments will make excellent candidates for small sat missions.

Instrument Development Programs

- **PICASSO** - Conducts planetary and astrobiology science instrument feasibility studies, concept formulation, proof of concept instruments, and advanced component technology development (TRL 1-4)
 - Proposals received annually
 - Approx.~ 10- 12 awards
- **MatISSE**- Develops and demonstrates planetary and astrobiology science instruments to the point where they may be proposed in response to an AO (TRL 3-6)
 - Proposals received bi-annually
 - Approx. ~ 3-6 awards

Astrophysics Small Spacecraft Missions

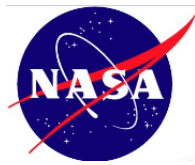

- **Explorer Program:**
 - The Explorers Program has provided flight opportunities for dozens of astrophysical missions. Seven have been 200 kg or less in mass.
 - Most Astrophysics Explorers under 200kg date from the 1960's and 1970's.
- **Why small satellites have not played a larger role in Astrophysics**
 - Small instruments typically cannot provide enough photons or enough angular resolution to exceed the capabilities of ground-based instruments.
 - In gamma ray astronomy a large mass is required to stop high energy photons.
- **As technology advances, smaller spacecraft will become more viable.**
 - 2 cubesat proposals received in 2011 ROSES cycle
 - 8 cubesat proposals received in 2012 ROSES cycle.
 - The Explorers Program will continue to be an option for funding small spacecraft.



Human Exploration and Operations

HEOMD: Cubesat Launch Initiative



- Launch opportunity available for cubesats from NASA, other government agencies, universities, other educational institutions, and US non-profit organizations.
- The research should address aspects of science, exploration, technology development, education or operations.
- No funding provided for satellite development but integration and launch is provided at no cost.
- Objectives:
 - Provide meaningful aerospace and STEM education
 - Advance the development of technologies
 - Conduct science research
- Implementation:
 - Annual call for proposals
 - Selection by panel including HEOMD, STMD, SMD, Education Office
 - Manifesting and integration overseen by NASA LSP
 - Referred to as ELaNa missions (Educational Launch of Nanosatellites)
 - Flown as auxiliary payloads on previously planned NASA or other government missions.
 - Cubesats are deployed using a standard Poly-Picosatellite Orbital Deployer (PPOD)

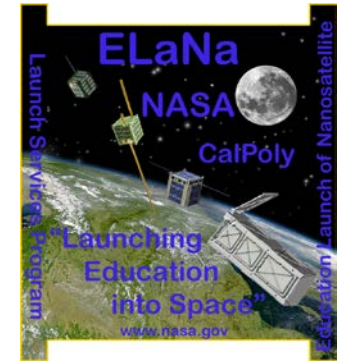

PPOD

HEOMD: Space Life and Physical Sciences

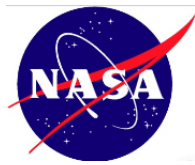

Current Space Biology Projects in Cooperation with SMD Astrobiology

Small Complete Missions of Opportunity in Astrobiology and Fundamental Space Biology AO (SALMON 2008) – 2 selected projects *SporeSat* and *EcAMSat*.

Future solicitations via standard annual Space Biology NRA; plan to select one project per year for development.

SporeSat

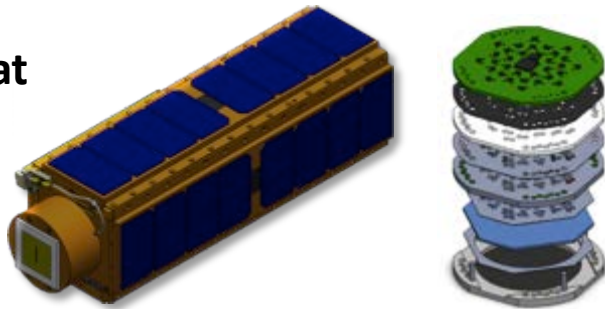

Objective:

To gain a deeper knowledge of the mechanism of cell gravity sensing by studying the activation of plant gravity sensing and electro-physical signaling in a single-cell model system (*Ceratopteris richardii*) using a “lab-on-a-chip” microsensor technology platform.

PI: Amani Salim, Purdue University
Engineering: Ames Research Center

EcAMSat

Escherichia coli
Antimicrobial Satellite

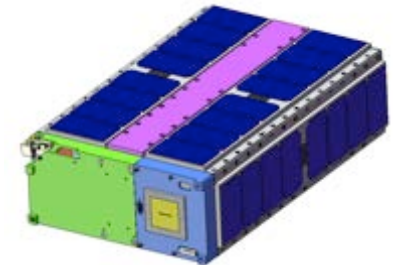

Objective:

To determine how microgravity alters antibiotic resistance of uropathogenic *Escherichia coli* (UPEC), including the role of a critical resistance gene that indicates a marked increase in UPEC antibiotic resistance

PI: A.C. Matin, Stanford
Engineering: Ames Research Center

ISS and SLS - Small Spacecraft Activity

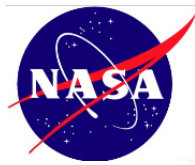

ISS Smallsat Deployment Opportunities

- Deployment of cubesats first began in 2013 via the JEM airlock
- Nanoracks now providing system for larger number of cubesat deployments
- Space Station Integrated Kinetic Launcher for Orbital Payload Systems (*SSIKLOPS*) will provide for deployment of larger smallsats

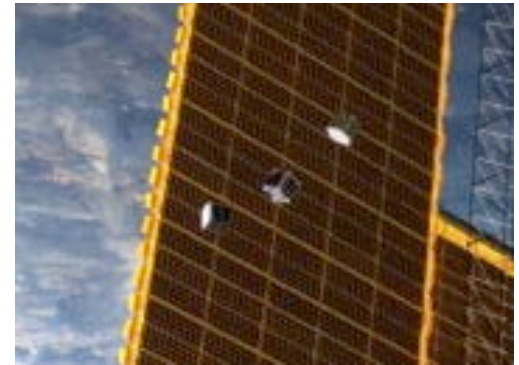

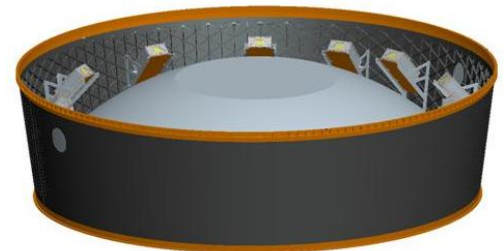

EM-1 and other SLS Secondary Payload Opportunities

- Planning for multiple 6U secondary payloads on EM-1 and subsequent flights – with deployment beyond LEO
- HEOMD sponsoring three 6U spacecraft projects
- STMD/SSTP considering technology projects
- STMD/Centennial Challenges considering prize challenge
- SMD considering science mission

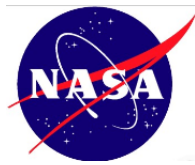

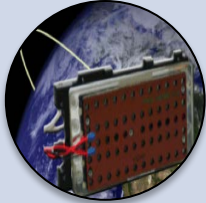
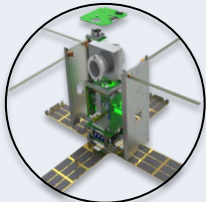

HEOMD Payloads under development for EM-1 Opportunity 6U Cubesats

Payload <i>NASA Centers</i>	Strategic Knowledge Gaps Addressed	Mission Concept
BioSentinel <i>ARC/JSC</i> 	Human health/performance in high-radiation space environments <ul style="list-style-type: none">• Fundamental effects on biological systems of ionizing radiation in space environments	Study radiation-induced DNA damage of live organisms in cis-lunar space; correlate with measurements on ISS and Earth
Lunar Flashlight <i>JPL/MSFC</i> 	Lunar resource potential <ul style="list-style-type: none">• Quantity and distribution of water and other volatiles in lunar cold traps	Locate ice deposits in the Moon's permanently shadowed craters
Near Earth Asteroid (NEA) Scout <i>MSFC/JPL/LaRC/JSC/GSFC</i> 	Human NEA mission target identification <ul style="list-style-type: none">• NEA size, rotation state (rate/pole position) How to work on and interact with NEA surface <ul style="list-style-type: none">• NEA surface mechanical/geotechnical properties	Flyby/rendezvous and characterize one or more NEAs that are candidates for a human mission

Asteroid Redirect Mission

Partnerships for Secondary Payloads

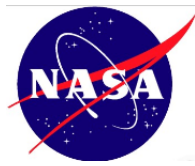

The Planetary Society: Transport extremophiles through deep space and return them to Earth to test panspermia theory.



Deep Space Industries: Assessing low-cost commercial spacecraft for compatibility with the ARV and SLS to address Strategic Knowledge Gaps.

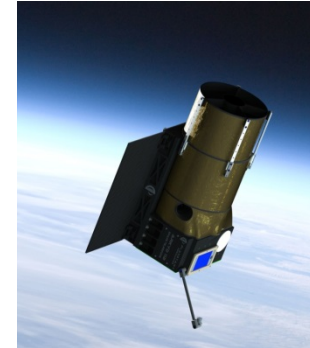

Planetary Resources: Adapting small low-cost commercial spacecraft to enhance ARM.



Applied Physics Lab: Hopper dropped on asteroid surface to measure elemental composition of asteroid regolith at multiple locations.

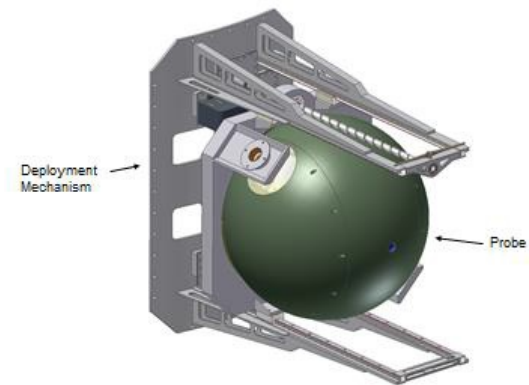

Honeybee Robotics: Multiple small kinetic impactors deployed from ARV to characterize regolith properties.

REFERENCE:

European Space Agency

Cubesat Missions for In-Orbit Technology Demonstration

Roger Walker,

Directorate of Technology and Quality Management

ESA/ESTEC

29 May 2014

- Contractor: Royal Meteorological Institute and KU Leuven (Belgium)
- Sun-Earth radiometric science demonstrator:
 - Measure the Essential Climate Variables of Total Solar Irradiance, Earth Radiation Budget and Sun-Earth radiation imbalance
 - Payload: absolute cavity radiometer (RMI), 3-axis ADCS with star tracker (KUL)
 - Platform: 3U CubeSat (ISIS)
 - Heritage: Sova-P instrument on CNES Picard mission; Diarad on SOHO
 - Launch on QB50 flight in 2016 to 380x700 km altitude, 98° inclination

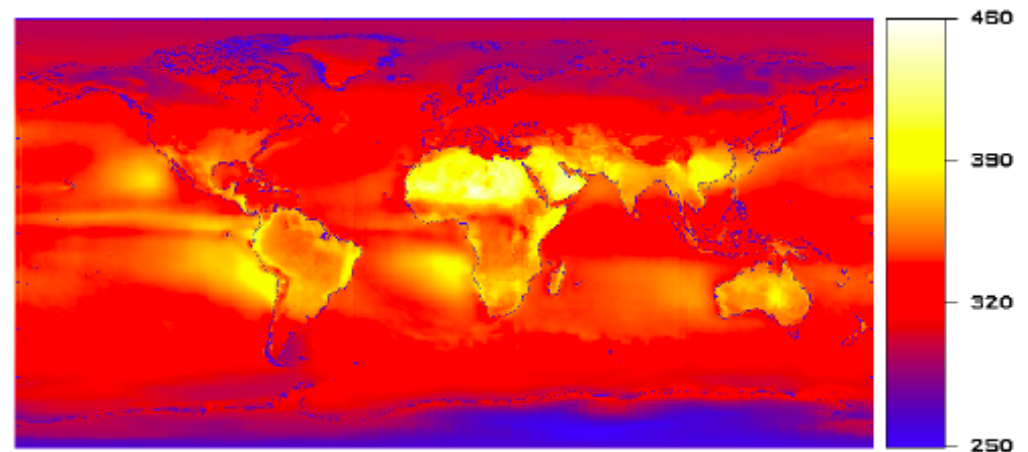
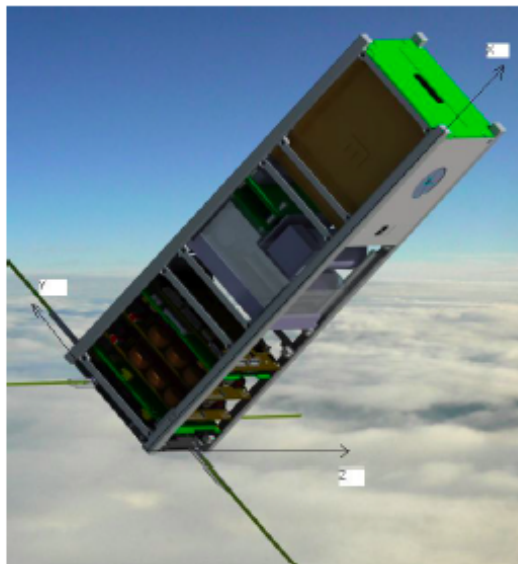

Credit: RMIB

- Contractor: Von Karman Institute (Belgium)
- Atmospheric re-entry demonstrator
 - New heat shield materials -> ablation, plasma field measurements
 - Aerodynamic drag augmentation and passive attitude stabilisation system
 - Telemetry data relay system during re-entry via the Iridium constellation
 - Launch on QB50 flight in 2016 to 380 km altitude, 98° inclination
 - Platform: custom, subsystems from various suppliers

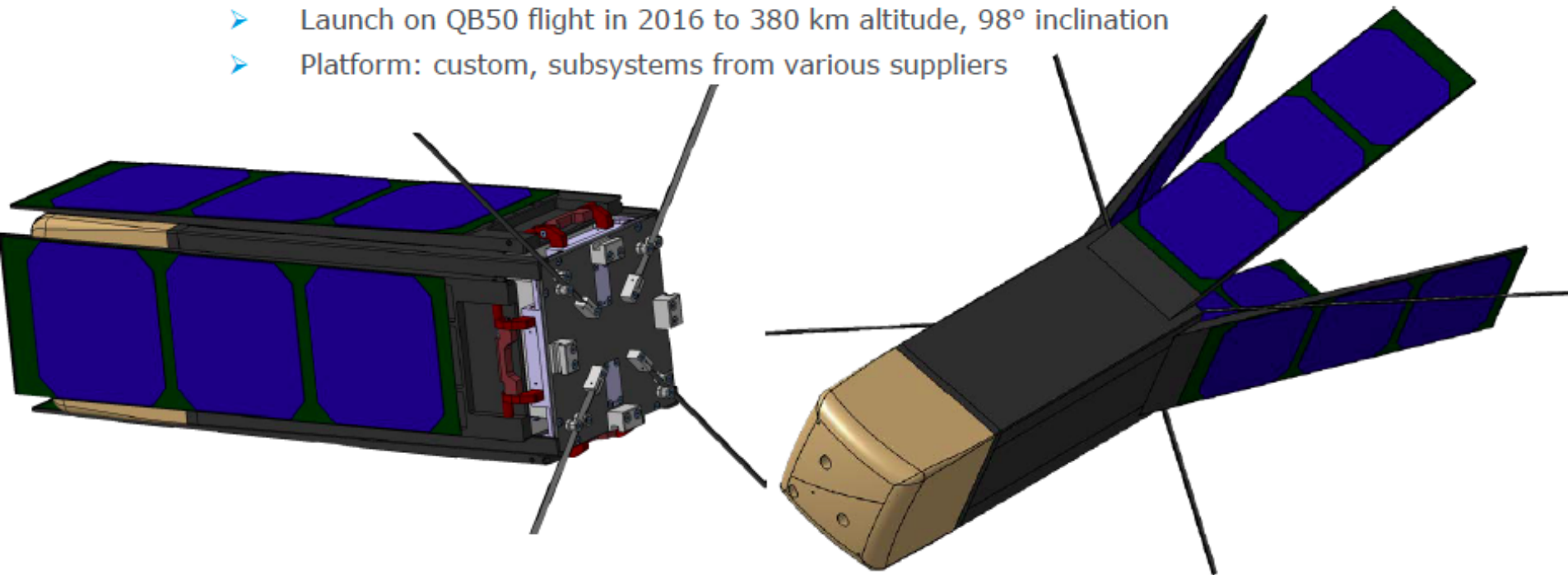

Credit: VKI

- Belgian Institute of Space Aeronomy, Royal Observatory Belgium, VTT Finland
- Atmospheric chemistry science demonstrator
 - Stratospheric Ozone distribution -> limb sounding of solar disk with multi-spectral imager
 - Mesospheric Temperature profile -> multi-spectral imager (VTT)
 - Electron density in the ionosphere -> multi-Needle Langmuir Probe
 - Earth Radiation Budget -> micro-bollimetric oscillation system
 - Platform: 3U CubeSat (Clyde Space)
 - Launch on QB50 flight in 2016 to 380x700 km altitude, 98° inclination

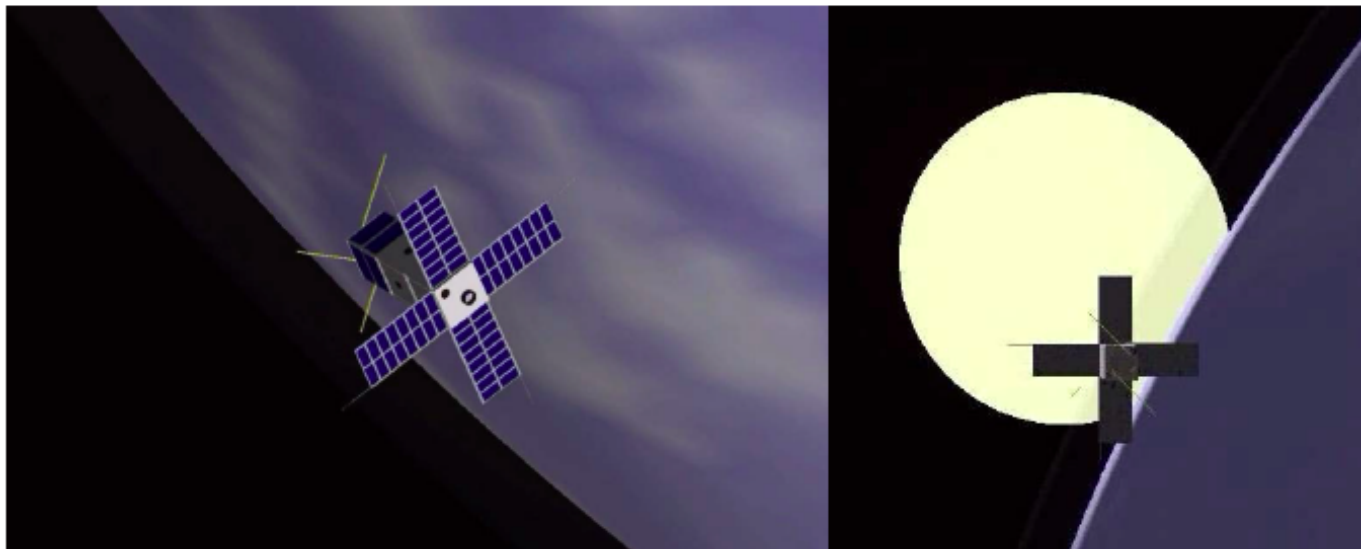

Credit: BISA

- Contractor: GomSpace (Denmark)
- 3U CubeSat telecommunications payload demonstrator
 - Improved Detection/de-coding of ADS-B signals broadcast by aircraft
 - Characterisation of Spot beams broadcast by GEO telecom satellites
 - Primary Payload: L-band Reconfigurable Software Defined Radio receiver
 - Additional payload: 3-axis ADCS with IR horizon sensors for nadir pointing accuracy of $\sim 1^\circ$ (day/night operation)
 - Launch to ISS via GomSpace/NanoRacks in July 2015
 - Deployment during Short Duration Mission of ESA astronaut Andreas Mogensen

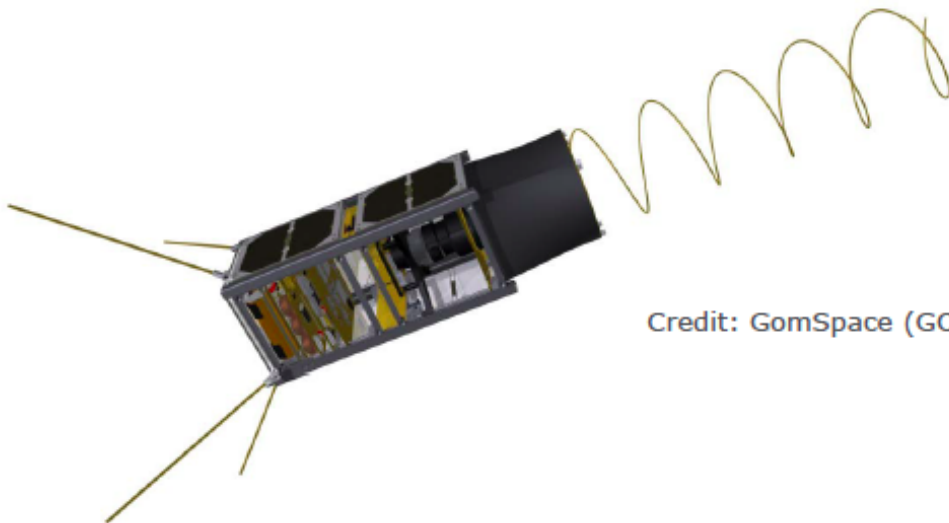

Credit: GomSpace (GOMX-1)

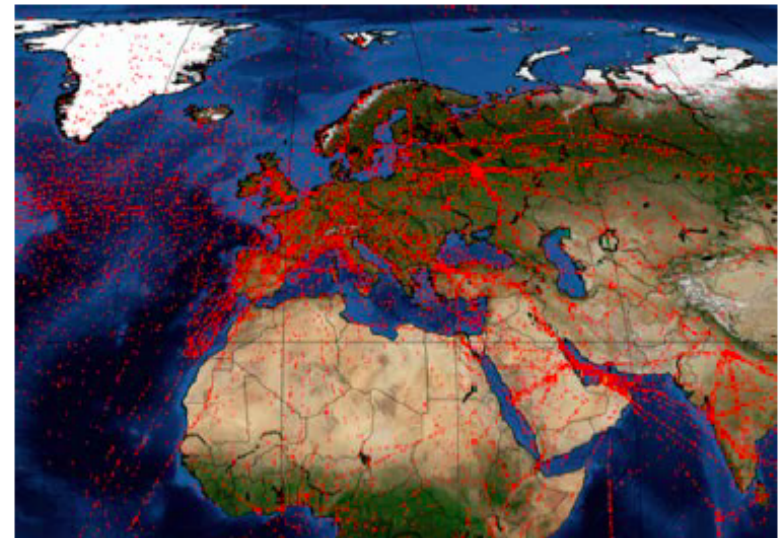

- Contractor: Swiss Space Center, EPFL
- Objective:
 - IOD and operational validation of critical ADR technologies at sub-scale for future use on full-scale missions to remove large debris objects
- Mission concept #1:
 - Rendezvous sensors (Flash Lidar, VIS & IR cameras)
 - Motion reconstruction of uncooperative target
- Mission concept #2:
 - Net capture system dynamics & target interaction
 - Coupled two-body tether dynamics and control
- System concept:
 - 8U Chaser satellite + 4U Target satellite
 - Coupled together and launched in 12U deployment system
 - Low velocity mutual separation after LEOP
 - Close proximity ops with 6 DoF chaser around "passive" target with settable attitude rates

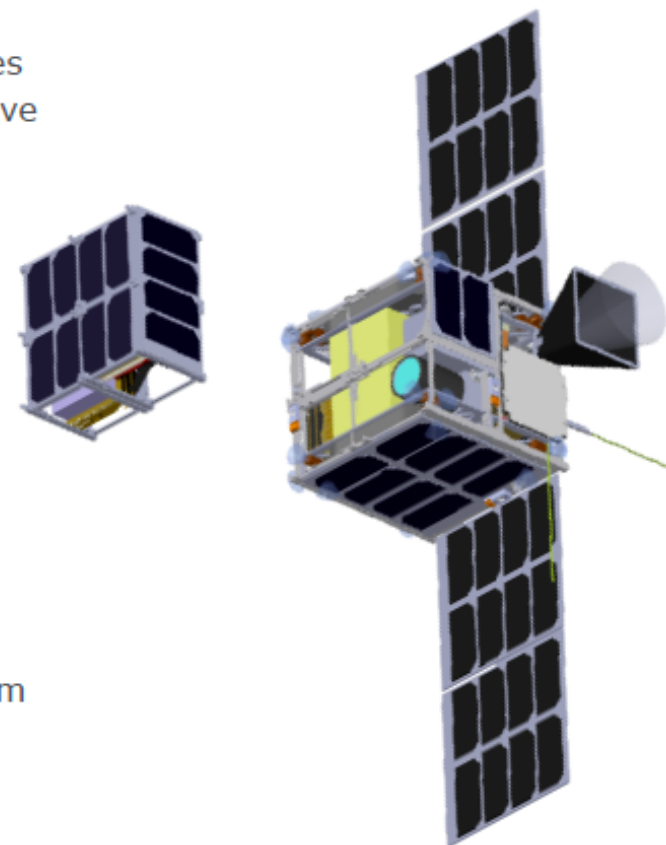

Credit: Swiss Space Center

European Space Agency

Small Spacecraft Technology

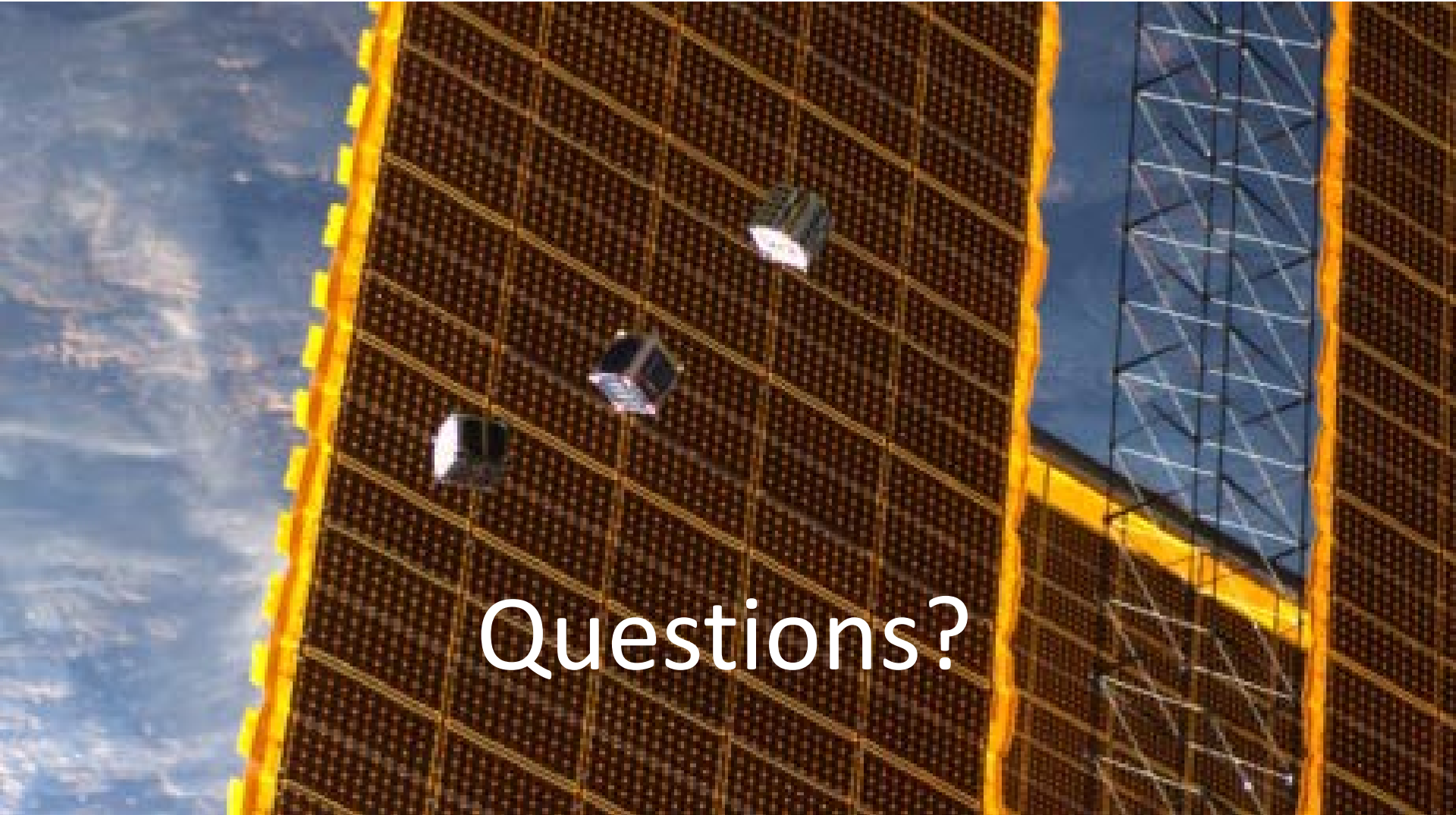

Questions?

BACKUP

SBIR – Deep Space Cubesat Technology

2014 Phase 1 Projects

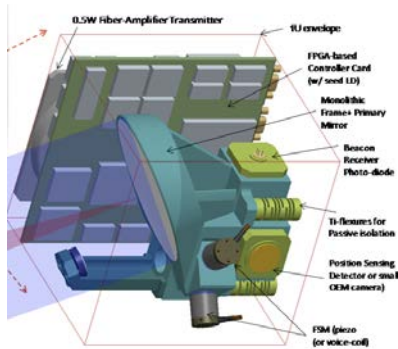
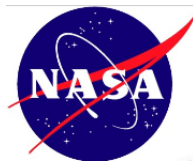

COMMUNICATIONS AND NAVIGATION

1U Cubesat Lasercom Terminal for Deep Space Communication

Fibertek, Inc. - Herndon, VA

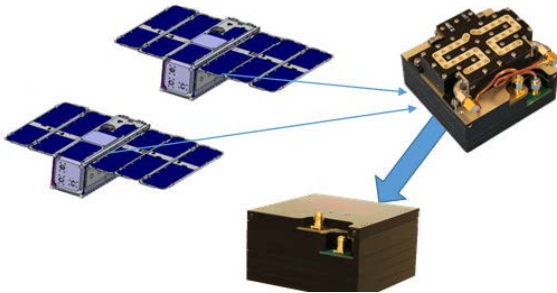

Deep Space Cubesat Regenerative Ranging Transponder

Innoflight, Inc. - San Diego, CA

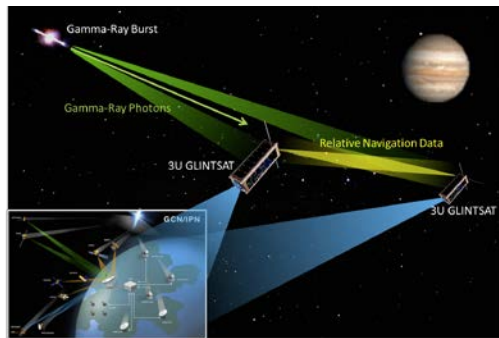

Deep Space Cubesat Gamma-ray Navigation Technology Demonstration

ASTER Labs, Inc. - Shoreview, MN

SBIR – Deep Space Cubesat Technology

2014 Phase 1 Projects

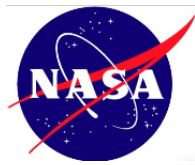

POWER GENERATION



High Power Betavoltaic Technology

MicroLink Devices, Inc. - Niles, IL

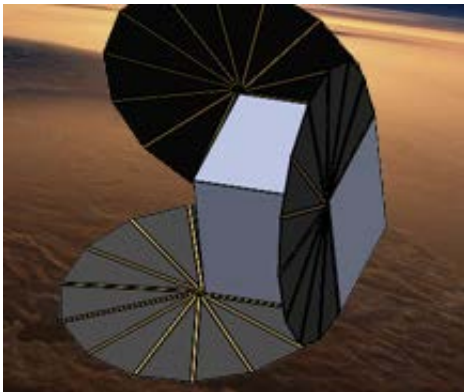

Deployable Solar Energy Generators for Deep Space Cubesats

Nanohmics, Inc. - Austin, TX

SBIR – Deep Space Cubesat Technology

2014 Phase 1 Projects

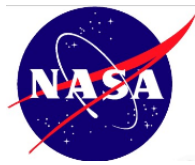

PROPULSION



Cubesat Ambipolar Thruster for LEO and Deep Space Missions

Aether Industries, LLC - Ann Arbor, MI



Multi-Purpose Interplanetary Deployable Aerocapture System

Altius Space Machines, Inc. - Louisville, CO

SBIR – Deep Space Cubesat Technology

2014 Phase 1 Projects

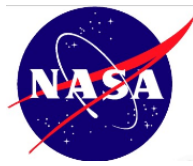

DEEP SPACE BUS

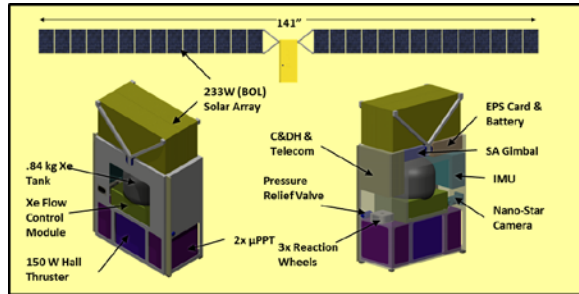

Solar Electric Propulsion Cubesat Bus for Deep Space Missions

ExoTerra Resource LLC - Lone Tree, CO

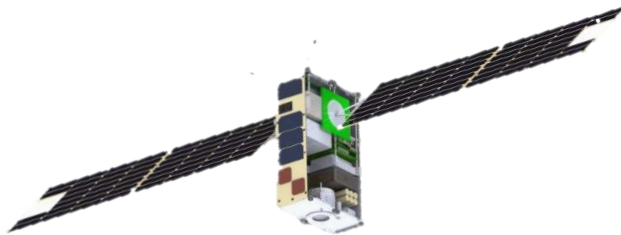

LunarCube for Deep Space Missions

Busek Company Inc. - Natick, MA