

National Aeronautics and Space Administration

Press Kit/June 2013

Interface Region Imaging Spectrograph (IRIS):

Understanding how the sun powers its million-degree atmosphere



Media Contacts

Steve Cole

NASA Headquarters
Sciences Mission Directorate

Public Affairs Officer

202-358-0918

Stephen.e.cole@nasa.gov

Susan Hendrix

NASA's Goddard Space Flight Center
Greenbelt, Md.

Public Affairs Officer

301-286-7745

susan.m.hendrix@nasa.gov

Rachel Hoover

NASA's Ames Research Center
Moffett Field, Calif.

Public Affairs Officer

650-604-0643

Rachel.hoover@nasa.gov

George Diller

NASA's Kennedy Space Center
Cape Canaveral, Fla.

Launch Operations Public Affairs

321-867-2468

george.h.diller@nasa.gov

Barry Beneski

Orbital Sciences Corporation
Greenbelt, Md.

Launch Systems Manager

703-406-5528

beneski.barron@orbital.com

Buddy Nelson

Lockheed Martin Corporation
Palo Alto, Calif.

Public Relations Lead

510-797-0349

buddynelson@mac.com

For more information about IRIS, visit:

www.nasa.gov/iris

Table of Contents

Media Services Information	4
Executive Summary	7
IRIS Mission Quick Facts	8
Orbital Pegasus XL Launch Profile	9
IRIS Observatory Quick Facts	10
IRIS Mission Overview	11
IRIS Mission Operations	12
IRIS Mission Management	14
NASA Launch Services Program	15
IRIS Program/Policy Management	16
Solar Science Basics	17

Media Services Information

NASA Television

NASA Television's Public, Education and Media channels are available for downlink on satellite AMC 3. Additionally, NASA TV has reformatted its online program schedule to improve its readability.

Cable and satellite service providers, broadcasters, and educational and scientific institutions will need to re-tune their receiving devices to AMC 3 to continue accessing NASA TV for distribution.

News networks, their reporters and other broadcast media organizations must tune their satellite receivers to the Media Channel to ensure reception of clean feeds for all mission coverage, news conferences, and other agency distributed news and information. News and other media organizations will no longer be able to rely on content from the Public Channel for clean feeds of mission and other agency activities.

NASA TV's occasional HD feed and Live Interactive Media Outlet (LIMO) Channel have also migrated to AMC3. For complete downlink information, visit:

http://www.nasa.gov/multimedia/nasatv/satellite_info.html

NASA Television has made its online program schedule easier to read, with schedules for all three channels listed on one page. Listings of upcoming programs, events and features on NASA TV's Public, Education and Media channels now can be accessed easily at:

<http://www.nasa.gov/multimedia/nasatv/schedule.html>

NASA TV Multichannel Broadcast Includes:

- Public Services Channel (Channel 101)
- Education Channel (Channel 102)
- Media Services Channel (Channel 103)

Analog NASA TV is no longer available. For digital downlink information for each NASA TV channel, schedule information for mission activities, and access to NASA TV's public channel on the Web, visit:

www.nasa.gov/ntv

Pre-Launch News Briefing

A L-21 pre-launch news briefing about the IRIS mission was held June 4, 2013, at 1 p.m. EDT at NASA Headquarters and broadcast live on NASA Television.

Pre-Launch Readiness Press Conference

The prelaunch readiness press conference will be held at Noon PDT on Tuesday, June 25, 2013, in the NASA News Room in the NASA Resident Office at Vandenberg Air Force Base in Calif. Immediately following that will be the IRIS science briefing. These briefings will be broadcast live on NASA Television. Media advisories will be issued in advance, outlining details of the news conferences.

Accreditation and Media Access Badges for VAFB

All news media, including those who are permanently badged, must complete the accreditation process for the activities associated with the IRIS launch.

To request accreditation, news media must contact 2nd Lt. Kaylee Ausbun, 30th Space Wing Public Affairs Office, Vandenberg Air Force Base at 805-606-3595, or kaylee.ausbun@us.af.mil, or by fax at 805-606-4571.

Information required is full legal name, date of birth and media affiliation. Foreign media also should include nationality and passport number. Government-issued photo identification will be required to enter Vandenberg.

KSC News Center Hours for Launch

The NASA News Center at KSC will provide updates to the media advisories. Launch status reports will be recorded on the KSC news media Codaphone that may be accessed by dialing 321-867-2525 starting June 24, 2013. News center hours on L-2 and L-1 will be from 8 a.m. to 4:30 p.m. PDT and 8 a.m. to 8 p.m. PDT on launch day.

NASA Television Coverage

For information about NASA Television coverage of the launch, visit:

<http://www.nasa.gov/multimedia/nasatv/digital.html>

NASA Web Prelaunch and Launch Coverage

NASA's home on the Internet, <http://www.nasa.gov> will provide extensive prelaunch and launch day coverage of the IRIS mission.

Multimedia Gallery

IRIS images, high-definition video and animations can be found at:

http://www.nasa.gov/mission_pages/iris/multimedia/index.html

IRIS Press Releases and Mission News

A link to all NASA IRIS press releases and mission news can be found at:

http://www.nasa.gov/mission_pages/iris/news/index.html

Executive Summary

The goal of the IRIS mission is to better understand how energy and plasma move from the sun's surface called the photosphere, through the chromosphere layer of the sun's atmosphere to the outer corona layer. IRIS will open a window of discovery into this crucial region by providing observations necessary to pinpoint the physical forces in this largely unexplored area near the surface of the sun.

IRIS is the first mission designed to simultaneously observe the range of temperatures specific to the chromosphere and transition region not only at very high resolution, but also at the quick rate of once every few seconds. The IRIS spacecraft will fly in a polar orbit for nearly continuous solar observations on its two-year mission to observe this region.

IRIS is a NASA Small Explorer mission. The Explorer Program Office at NASA's Goddard Space Flight Center in Greenbelt, Md., provides management of the multiple scientific exploration missions within this program. Explorer missions are principal investigator-led, relatively moderate cost, small to medium-sized missions that are capable of being built, tested and launched in a short time interval compared to large observatories.

IRIS will complement the NASA Solar Dynamics Observatory (SDO) and JAXA/NASA Hinode missions to explore how the solar atmosphere works and impacts Earth—SDO and Hinode monitoring the solar surface and outer atmosphere, with IRIS watching the region in between.

IRIS Mission Quick Facts

Launch Date:	June 26, 2013
Launch Site:	Vandenberg Air Force Base, Calif.
Launch Vehicle:	L-1011 carrier aircraft with an Orbital Pegasus XL rocket
L-1011 Lift Off:	Targeted for 6:35 pm PDT
Spacecraft Deploy:	Targeted for 7:27 pm PDT
Orbit:	Sun-synchronous orbit (pole to pole) 620 km x 670 km (385 x 420 miles), inclined 97.89 degrees to the equator
Orbital Period:	97 minutes
Mission Duration:	Two-years.
Mission Operations:	NASA's Ames Research Center, Moffett Field, Calif., will perform ground commanding, flight operations and data telemetry.
Science Operations:	Lockheed Martin Solar and Atmospheric Laboratory, in Palo Alto, Calif., will perform science operations. Stanford University in Stanford, Calif., will provide data processing and archiving.
Ground Data Passes:	The Norwegian Space Centre and NASA's Near Earth Network will provide the ground stations using antennas at Svalbard, Norway, Fairbanks, Alaska, McMurdo, Antarctica and Wallops Island, Va.

Pegasus XL Rocket Launch Profile

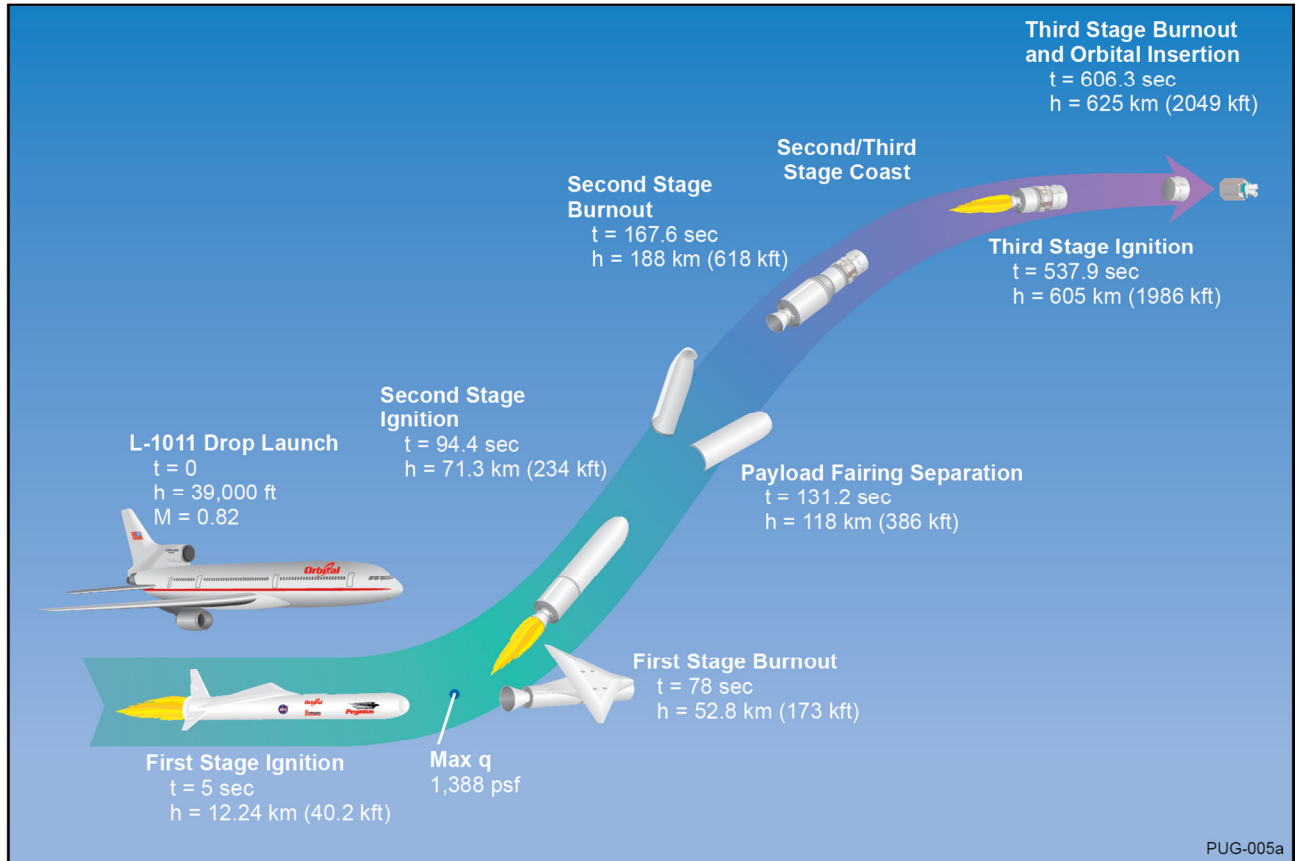

*Pegasus XL Mission Profile to 620 x 670 km Sun Synchronous Orbit with a 181 kg (399 lbs) IRIS Payload.
 Credit: Orbital Sciences Corporation*

IRIS Observatory Quick Facts

Mass: Total observatory mass is 183kg (403 lbs). Payload is 87k (192 lbs) and spacecraft bus is 96k (211 lbs). There is no onboard fuel.

Power: Maximum power consumption is 340 Watts.

Dimensions: The observatory is 86 inches from the back of the bus to the front of the telescope. The solar arrays deployed are 12 feet wing to wing.

High-gain Antenna: X-band, fixed, fixed-directional.

Low-gain Antenna: S-band, omni-directional.

Solar Arrays: The solar arrays are 25 inches x 53 inches, each with two panels total, providing a total surface area of 2,650 square inches, or 18.4 SF.

Maximum Downlink Rate: The science X-band data rate is 15 Mbps, delivered over 15 downlink passes, for a total rate of 60 gigabits/day.



Image Caption: NASA's Interface Region Imaging Spectrograph with solar panels in flight position during pre-flight checkouts in the clean room at Lockheed Martin Advanced Technology Center in Palo Alto, Calif.

Credit: Lockheed Martin Solar and Astrophysics Laboratory

IRIS Mission Overview

NASA's Interface Region Imaging Spectrograph (IRIS) will advance our understanding of the role the interface region, which lies between the sun's photosphere and corona, plays in powering its dynamic million-degree atmosphere and drives the solar wind. The interface region is where most of the sun's ultraviolet emission is generated that impacts the near-Earth space environment and Earth's climate.

Tracing how material and energy move through this region is a crucial part of understanding the dynamics of the sun and the link between the sun and Earth. Information from IRIS will help scientists explain what causes the steady stream of the solar wind, and larger, more explosive eruptions such as coronal mass ejections, or CMEs.

Tracking the complex processes within the chromosphere requires instrument and modeling capabilities that are for the very first time within our technological reach with IRIS. Visible in ultraviolet light, the chromosphere forms a violently dynamic interface region in which hot and cold plasma are mixed over a range of heights, stretching from the sun's surface to several thousand miles up.

The imaging spectrograph on IRIS is designed specifically for the purpose of measuring the spectral content of light from the interface region of the sun. IRIS will take spectra of this key region at least an order of magnitude faster than any previous solar observatory. Since IRIS is essentially examining features on the sun that change very rapidly, a very fast image cadence is paramount in "chopping up" these very rapid events into small discrete pieces. This approach will ensure that changes over time in temperature, pressure and velocity can be observed and modeled to better understand the driving mechanisms of space weather.

Information obtained from IRIS will significantly increase our understanding of the detailed process by which energy that is stored and transported through the interface region is transformed to eventually result in the space weather seen far away at Earth.

IRIS Mission Operations

Mission Orbit

IRIS will be placed into a sun-synchronous orbit (pole to pole) 620 km x 670 km (385 x 420 miles), inclined 97.89 degrees to the equator, with a 97-minute orbit. The spacecraft's orbit will place it about 620 km (385 miles) above Earth's surface at its closest point, and at 670 km (420 miles) at the farthest. This orbit provides eight months of continuous observations per year and maximizes eclipse-free viewing of the sun.

Data Path and Rate

NASA's Ames Research Center is responsible for mission operations and the ground data system. The Norwegian Space Centre will provide the primary ground station at Svalbard, Norway, inside the Arctic Circle.

The X-band data rate is 15 Mbps, delivered over 15 downlink passes, for a total rate of 60 Gb each day.

IRIS Instrument

The IRIS instrument is a multi-channel imaging spectrograph with a 20 cm UV telescope. IRIS will obtain spectra along a slit (1/3 arcsec wide), and slit-jaw images. The charged coupled device (CCD) detectors will have 1/6 arcsec pixels. IRIS will have an effective spatial resolution between 0.33 and 0.4 arc second and a maximum field of view of 120 arc second.

The far-UV channel covers:

- 1332-1358 Å and 1390-1406 Å with 40 m Å resolution and an effective area of 2.8 cm².

The near-UV channel covers:

- 2785-2835 Å with 80 mÅ resolution and an effective area 0.3 cm².

Slit-jaw imaging will have four passbands:

- 1335 Å and 1400 Å with 40 Å bandpass each
- 2796 Å and 2831 Å with 4 Å bandpass each

IRIS will have a high data rate of 0.7 Mbit/s on average, so the baseline cadence is: 5s for slit-jaw images, 1s for 6 spectral windows, including rapid rastering to map solar regions.

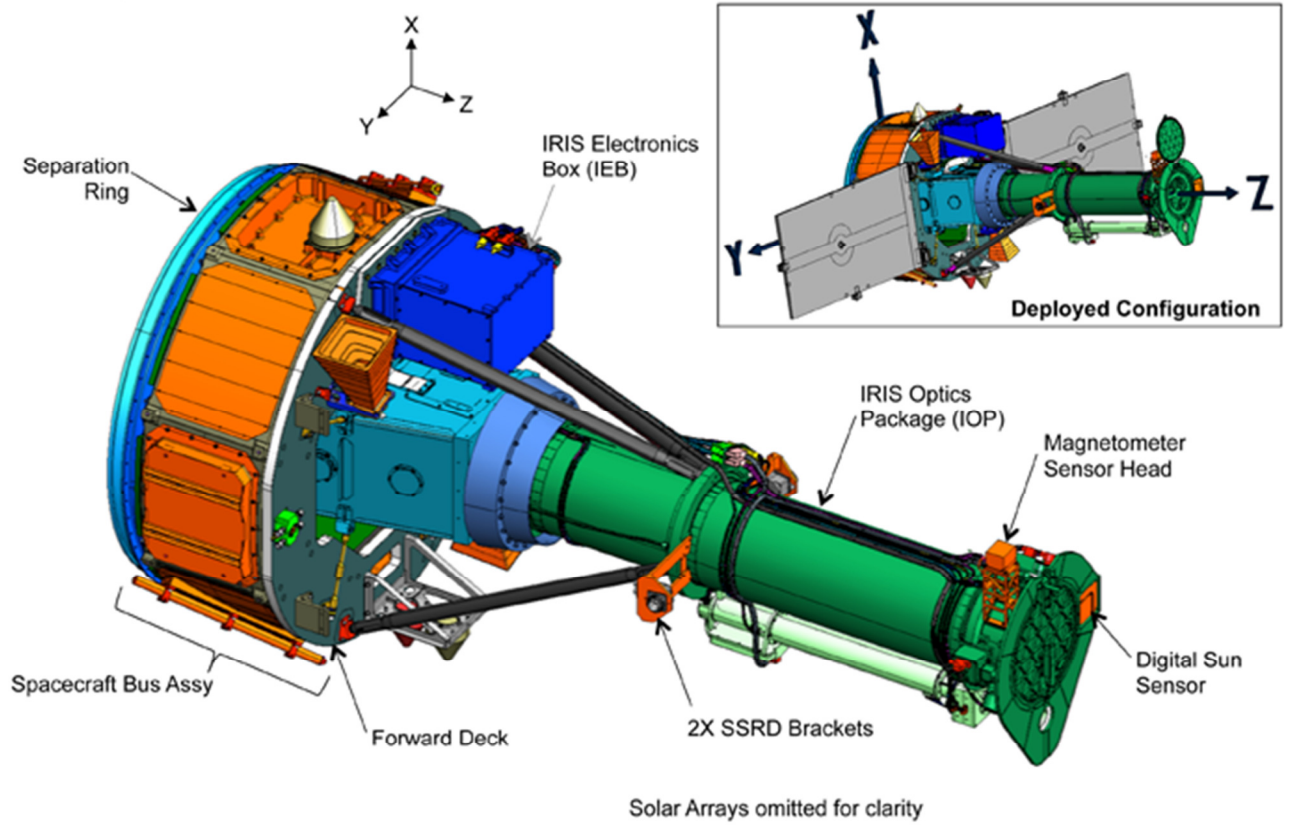

Image Caption: Artist illustration of NASA's Interface Region Imaging Spectrograph (IRIS) observatory. Credit: Lockheed Martin Solar and Astrophysics Laboratory

IRIS Mission Management

IRIS is a Principal Investigator led, NASA Small Explorer Program mission. Primary management responsibilities are as follows:

NASA's Goddard Space Flight Center (Greenbelt, Md.):

- Explorers Program Management
- Project Oversight

NASA's Ames Research Center (Moffett Field, Calif.):

- Mission Operations
- Management and Technical Engineering Support for instrument and spacecraft development teams
- Science
- Education and Public Outreach

Lockheed Martin Solar & Astrophysics Lab (Palo Alto, Calif.):

- Principal Investigation institution
- Project/Instrument Management
- Flight software
- Electronics
- Telescope
- Integration and Test

Smithsonian Astrophysics Observatory (Cambridge, Mass.):

- Telescope Design for spectrograph
- Science
- Education and Public Outreach

Montana State University (Bozeman, Mont.):

- Spectrograph design
- Science
- Education and Public Outreach
- Student Collaboration

Leland Stanford Junior University (Stanford, Calif.):

- Data Archive
- Science
- Education and Public Outreach

Lockheed Martin Sensing & Explorations Systems (Sunnyvale, Calif.):

- Spacecraft
- Observatory Integration and Test

NASA's Launch Services Program

NASA turns to the engineers and analysts in its Launch Services Program, or LSP, to send robotic spacecraft on their way for some of the most exciting and notable missions in the agency's history.

The Program is based at NASA's Kennedy Space Center, Fla., and boasts a roster of engineers and technicians who specialize in all aspects of rocketry and spacecraft integration. LSP selects the appropriate launcher for a mission's spacecraft, in this case the Orbital Sciences Pegasus XL for NASA's IRIS. Sometimes this selection process takes place years before the first launch opportunity. The program then provides oversight as the designs of the rocket and mission are integrated with each other.

As liftoff nears, teams oversee the launch vehicle's engineering and manufacture and its integration with the spacecraft. LSP conducts the countdowns for NASA's scientific missions and provides additional quality assurance along with other controls to ensure a successful mission.

Working with commercial rocket builders, planners have a number of rocket models to choose from, ranging from the small, air-launched Orbital Sciences Pegasus used for IRIS, to the workhorse Delta II rocket from United Launch Alliance, to the powerhouse Atlas V, also from ULA. The catalog is growing with the addition of the Space X, Falcon 9 and Orbital Sciences Antares rockets.

LSP moved its operations to Kennedy in 1998, becoming the first program based at the nation's premiere launch site. The 14 years since then have seen orbiters, landers and rovers to Mars, huge observation spacecraft to Jupiter and the New Horizons mission launched to Pluto and the Kuiper Belt, two astronomical locations that have never been seen up-close before.

Because some spacecraft need to fly in a different kind of orbit, LSP operates several launch centers around the world. Cape Canaveral Air Force Station in Florida is adjacent to Kennedy Space Center and hosts launches to place spacecraft in orbits that remain close to the equator. The LSP team travels to Vandenberg Air Force Base to run launches that require spacecraft to fly around the world in a north-to-south orbit, known as a polar orbit. The IRIS spacecraft will operate in a roughly polar orbit, so the launch will take place at Vandenberg. LSP also conducts launches from Kwajalein in the Marshall Islands, Kodiak Island, Alaska and NASA's Wallops Flight Facility on Virginia's eastern Shore.

To learn more about LSP, rockets and NASA missions go to:

<http://www.nasa.gov/centers/kennedy/launchingrockets/index.html>

IRIS Program/Policy Management

Associate Administrator Science Mission Directorate

John Grunsfeld
NASA Headquarters, Washington

IRIS Program Scientist

Jeffrey Newmark
NASA Headquarters, Washington

IRIS Program Executive

George Albright
NASA Headquarters, Washington

IRIS Mission Manager

Eric Ianson
NASA's Goddard Space Flight Center
Greenbelt, Md.

Heliophysics Science Division

Michael Hesse
NASA's Goddard Space Flight Center
Greenbelt, Md.

IRIS Project Scientist

Joseph Davila
NASA's Goddard Space Flight Center
Greenbelt, Md.

IRIS Deputy Project Scientist

Adrian Daw
NASA's Goddard Space Flight Center
Greenbelt, Md.

More information about NASA's IRIS mission can be found online at:

www.nasa.gov/iris

<http://iris.lmsal.com>

Solar Science Basics

What Is Heliophysics?

Heliophysics is the exploration of the magnetic variable star we call the sun, its effects on the planets of the solar system, including Earth, and the dynamic environmental conditions in the space surrounding the sun and planets.

What is the “interface region?”

The sun’s dynamically changing chromosphere and transition region make up the key interface region that IRIS will study, which lies between the photosphere and corona.

What Is Space Weather?

Space weather originates with the variable magnetic activity of the sun. Activity on the sun’s surface, such as solar flares and coronal mass ejections, or CMEs, can cause high levels of radiation in space. This radiation comes to Earth as plasma (electrically charged particles) or electromagnetic radiation (light), including X-rays and ultraviolet wavelengths. Space weather includes any and all conditions and events on the sun, in the solar wind, in near-Earth space and in our upper atmosphere that can affect space-borne and ground-based technological systems and through these, human life and endeavor. Heliophysics is the science of space weather.

What Is the Solar Cycle?

While the sun goes through cycles of high and low activity that repeat about every 11 years, solar cycles as short as 9 years and as long as 14 years have been observed. The solar or sunspot cycle is a useful way to mark changes in the frequency and strength of CMEs, solar flares, and other solar activity. About every 11 years the sun’s magnetic field changes polarity from north to south. Eleven years later it flips back.

During solar minimum, the sun may churn out strong CMEs every two days; that’s approximately 180 CMEs per year, although only about 10 to 15 CMEs are directed at Earth. During solar maximum, the sun averages five CMEs daily and sends about 100 to 150 CMEs toward Earth each year.