

## Crystal Growth and Buoyancy-Driven Convection Currents

### Objective:

- To observe buoyancy-driven convection currents that are created as crystals grow in a crystal growing solution.

### Science Standards:

- Science as Inquiry
- Physical Science
  - position and motion of objects
  - properties of objects and materials
- Unifying Concepts and Processes
- Change, Constancy, & Measurement

### Science Process Skills:

- Observing
- Communicating
- Measuring
- Collecting Data
- Inferring
- Predicting
- Hypothesizing

### Mathematics Standards:

- Measurement

### Activity Management:

This activity is best done as a demonstration. While it is easy for students to grow crystals by following the directions, the success of observing the density-driven convection currents depends upon a very still environment. The crystal-growing chamber should be placed on a firmly mounted counter where it will not be disturbed. The convection currents are very sensitive to vibrations. Place a slide projector on one side of the chamber and direct the

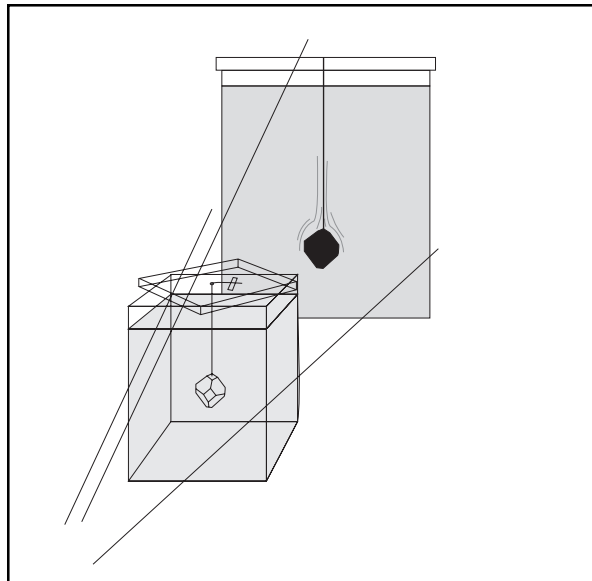

Gravity-driven convection currents are created in a crystal growth chamber by the interaction of the growing crystal and the solution.

### MATERIALS AND TOOLS

- Aluminum potassium sulfate  $\text{AlK}(\text{SO}_4)_2 \cdot 12\text{H}_2\text{O}^*$  (alum)
- Square acrylic box\*\*
- Distilled water
- Stirring rod
- Monofilament fishing line
- Silicone cement
- Beaker
- Slide projector
- Projection screen
- Eye protection
- Hot plate
- Thermometer Balance

\*Refer to the chart for the amount of alum needed for the capacity of the growth chamber (bottle) you use.

\*\*Clear acrylic boxes, about 10x10x13 cm, are available from craft stores. Select a box that has no optical distortions.



light from the projector through the growth chamber so it casts a shadow on the wall behind. If the wall behind the chamber is textured or a dark color, tape a piece of white paper there to act as a screen. Viewing may be improved by adding dark paper shields around the screen to reduce outside light falling on the screen. The projector can be replaced by a clear lightbulb of about 100 to 150 watts that has a straight filament. Place the bulb in a clip lamp light socket and aim the bulb so the filament is pointing directly at the growth chamber. This will make the bulb serve as a point source of light so the shadows will be clear. Do not use a reflective lamp shade with the light.

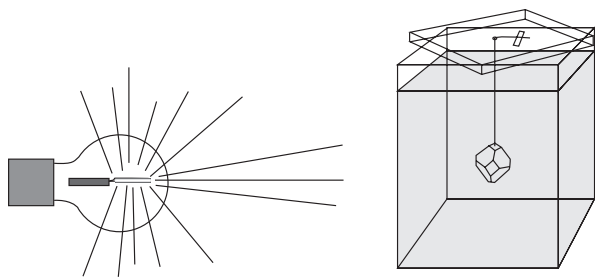

When preparing the crystal growing solution, be sure to follow routine safety precautions such as wearing eye protection. You can obtain this chemical from school science supply companies or even in food stores in the spice section. Alum is used in pickling.

To produce large alum crystals, it is necessary to obtain seed crystals first. This is accomplished by dissolving some alum in a small amount of water and setting it aside for a few days. Plan to do this step several weeks before you will use the demonstration with your students. To save time, dissolve as much alum as you can in warm water. This will produce a supersaturated solution when the liquid cools and crystallization will start shortly. After the seed crystals form (about 3-5 mm in size) pour the solution through some filter paper or a paper towel to capture the seeds. Let them dry before attaching the fishing line. In attaching the line, simply place a dab of silicone

cement on a piece of paper and then touch the end of a short length of monofilament fishing line to the cement. Then, touch the same end of the line to the crystal. Prepare several seed crystals in this manner. When the cement dries, you will be ready for the steps below.

You may discover mysterious variations in the growth of the crystal over several days. Remember, the amount of alum that can be dissolved in a given quantity of water will vary with the water's temperature. Warm water can hold more alum than cold water. If the air-conditioning in a building is shut off for the weekend, the temperature of the alum solution will climb with the room's temperature and some or all of the crystal may dissolve back into the water.

### Procedure:

1. Prepare the crystal growth solution by dissolving powdered or crystalline alum in a beaker of warm water. The amount of alum that can be dissolved in the water depends upon the amount of water used and its temperature. Refer to the plot (Alum Solubility in Water) for the quantity required.
2. When no more alum can be dissolved in the water, transfer the solution to the growth chamber acrylic box.
3. Punch or drill a small hole through the center of the lid of the box. Thread the seed crystal line through the hole and secure it in place with a small amount of tape. Place the seed crystal in the box and place the lid on the box at a 45 degree angle. This will expose the surface of the solution to the outside air to promote evaporation. It may be necessary to adjust the length of the line so the seed crystal is several centimeters above the bottom of the box.
4. Set the box aside in a place where it can be observed for several days without being disturbed. If the crystal should disappear, dissolve more alum into the solution and suspend a new seed crystal. Eventually, growth will begin.

- Record the growth rate of the crystal by measuring it with a metric ruler. The crystal may also be removed and its mass measured on a balance.
- Periodically observe the fluid flow associated with the crystal's growth by directing the light beam of a slide projector through the box to a projection screen. Observe plumes around the shadow of the crystal. Convection currents in the growth solution distort the light passing through the growth solution. Refer to the diagram at the beginning of this activity for information on how the observation is set up.

### Assessment:

Collect the student work sheets.

### Extensions:

- Try growing other crystals. Recipes for crystals can be found in reference books on crystal growing.
- Collect natural crystals and observe their surfaces and interiors (if transparent). Look for uniformity of the crystals and for defects. Make a list of different kinds of defects (fractures, bubbles, inclusions, color variations, etc.). Discuss what conditions must have existed in nature at the time of the crystal's formation or after its formation to cause the defects.
- Review scientific literature for results from microgravity crystal-growing experiments.

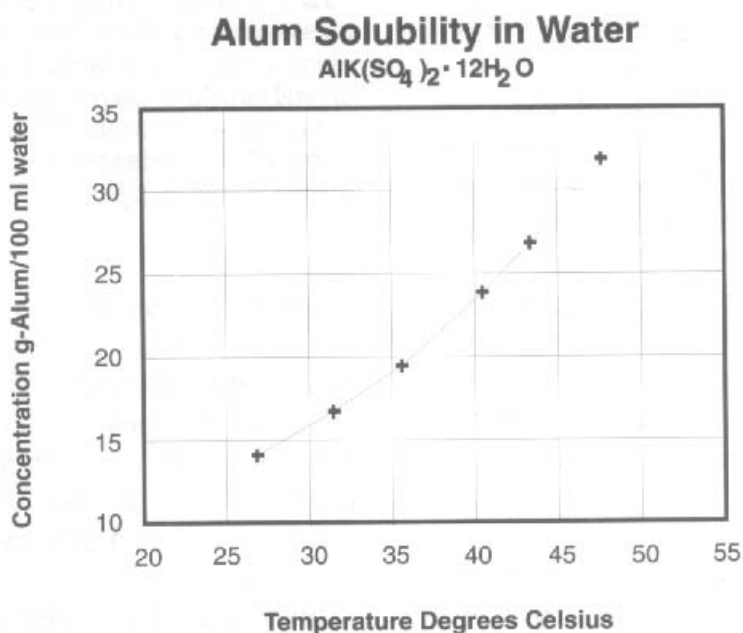

# Crystal Growth and Buoyancy-Driven Convection Currents

Crystals can be grown using a variety of methods. One of the simplest methods involves dissolving a solid into a liquid. As the liquid evaporates, the solid comes out of solution and forms a crystal (or many crystals). This can be done with sugar or salt or a variety of other compounds such as alum (aluminum potassium sulfate), LAP (L-arginine phosphate), or TGS (triglycine sulfate).

The usual procedure for growing crystals from a solution is to create the solution first. In this activity, a quantity of alum is dissolved into warm water. Warm water was used to increase the amount of alum that could be dissolved. You may have observed this effect by stirring sugar into a cup of hot coffee or tea. Hot liquids can dissolve more sugar than cold liquids. After the alum was dissolved, the solution was allowed to cool back down to room temperature. As a result, the water held more alum than it normally could at that temperature. The solution was supersaturated. A seed crystal was suspended in the solution and it began to grow. The excess alum dissolved in the water migrated to the crystal and was deposited on its surface. Because the crystal growth chamber was open to the surrounding air, the solution began evaporating. This continued the crystal growth process because the alum left over from the evaporated water was deposited on the crystal.

At first glance, the growth process of the alum crystal looks very quiet and still. However, examination of the solution and growing crystal with light to produce shadows shows that currents exist in the solution. These currents become visible when light is projected through them because the convection currents distort the light rays, making them appear as dark plumes on

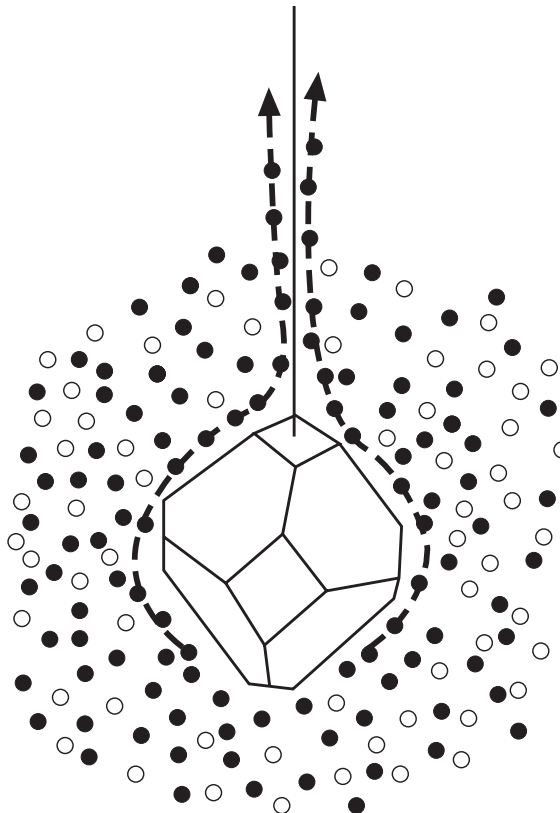

Water molecules in this diagram are represented by black dots and the alum dissolved represented by the lighter dots. Throughout most of the solution, the dots are randomly mixed but, next to the crystal, the dots are mostly black. This happens because the alum nearest the growing crystal attaches to the crystal structure, leaving behind the water. The remaining water is buoyant and rises while denser water with more dissolved alum moves next to the crystal to take its place.

the screen. This image on the screen is called a shadowgraph.

Where do these convection currents come from? The answer has to do with the difference in the amount of alum in solution near the growing crystal compared with the solution near the wall of the growth chamber. Except for near the

crystal, the solution is homogeneous. This means it has the same composition and density. The solution near the crystal is another matter. As each molecule of alum leaves the solution to become deposited on the crystal's surface, the solution left behind becomes slightly less dense than it was. The less dense solution is buoyant and begins to rise in the chamber. More dense solution moves closer to the crystal to take its place. The alum in the replacement solution also deposits on the crystal, causing this solution to become less dense as well. This keeps the convection current moving.

Microgravity scientists are interested in the convection currents that form around a crystal growing in solution. The currents may be responsible for the formation of defects such as liquid inclusions. These are small pockets of liquid that are trapped inside the crystal. These defects can degrade the performance of devices made from these materials. The virtual absence of buoyancy-driven convection in a microgravity environment may result in far fewer inclusions than in crystals grown on Earth. For this reason, solution crystal growth has been an active area of microgravity research.

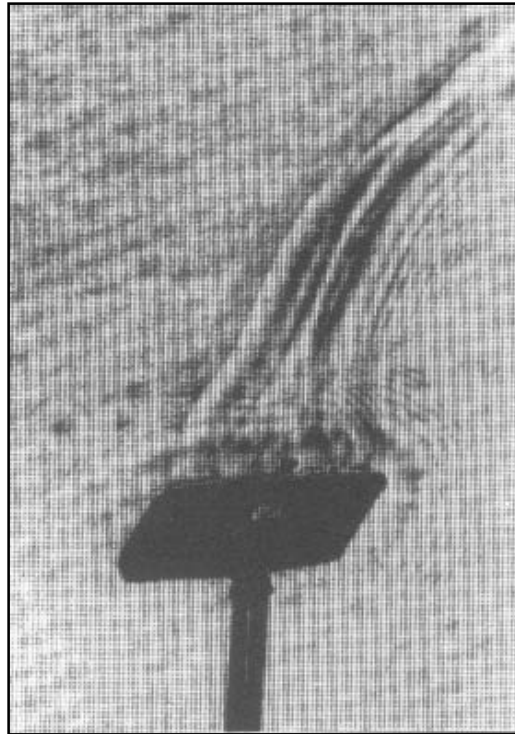

Shadowgraph image of a growth plume rising from a growing crystal.

# Crystal Growth and Buoyancy-Driven Convection Currents

Name: \_\_\_\_\_

1. In the box to the right, make a sketch of what you observed in the shadowgraph of a crystal growing from solution.
2. Explain below what is happening.

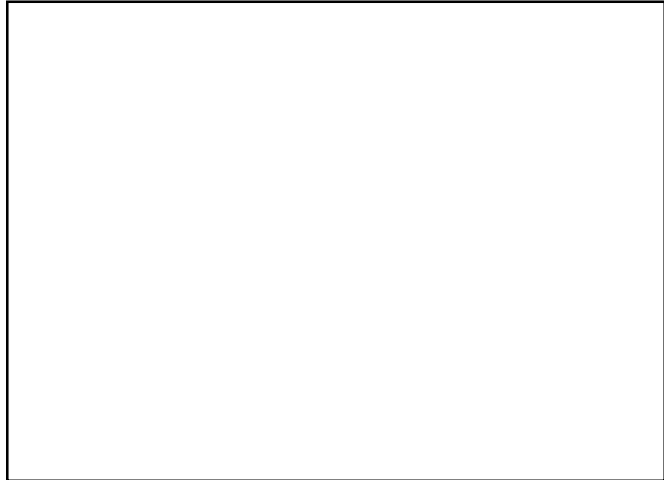

Shadowgraph for growing alum crystal

3. In the box to the right, sketch what a shadowgraph should look like for a crystal that is dissolving back into solution.
4. Explain your diagram below.



Shadowgraph for dissolving alum crystal



5. Draw a picture in the space to the right of what you think the shadowgraph should look like for a crystal grown from solution in a microgravity environment.

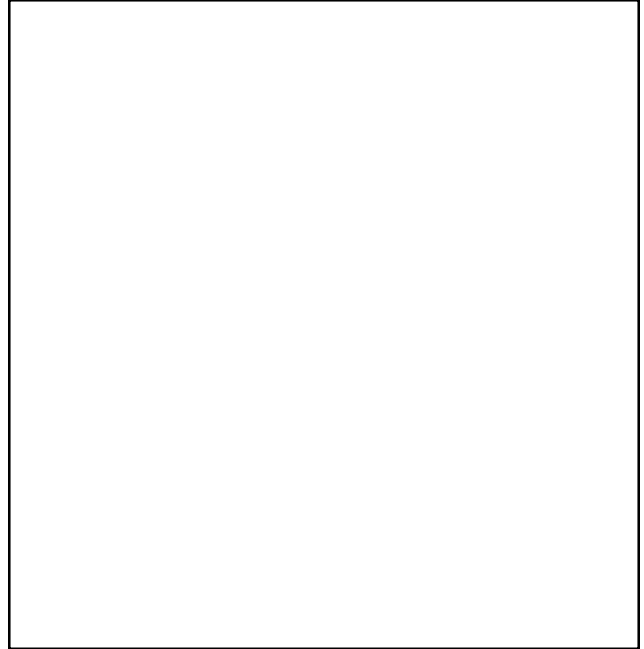

6. Explain your picture below.

Shadowgraph for alum crystal grown in microgravity

